



HEIDENHAIN



User's Manual

EIB 741 EIB 742

External Interface Box
for Connecting
HEIDENHAIN Encoders

SALES & SERVICE:

A Tech Authority, Inc.
13745 Stockton Ave.
Chino CA 91710
909-614-4522
sales@atechauthority.com

July 2013

DOCUMENTATION	5
FIRMWARE VERSION	5
CHANGE HISTORY.....	5
PART 1: FEATURES.....	6
1 GENERAL DESCRIPTION OF FUNCTION	6
2 CONFIGURATION OF THE ENCODER INPUTS.....	7
2.1 Processing Incremental Signals	7
2.2 Analog Values of the 1 Vpp Incremental Signals A and B:.....	9
2.3 Dealing with Reference Marks.....	9
2.4 Monitoring the Reference Marks.....	10
2.5 Processing EnDat Signals	11
2.6 Auxiliary Axis.....	14
3 PROCESSING OF TRIGGER EVENTS	15
3.1 Trigger Inputs and Outputs	15
3.2 Logical Inputs and Outputs.....	16
3.3 Trigger Module	16
3.4 Interval Counter.....	18
3.5 Maximum Trigger Rate	18
3.6 Counter for Accepted Trigger Events.....	18
4 TIMESTAMP	19
5 STATUS WORD.....	19
6 ETHERNET INTERFACE	22
7 OPERATING MODES	22
7.1 Configuration of Data Packets.....	22
7.2 "Polling" Operating Mode.....	24
7.3 "Soft Real-Time" Operating Mode	25
7.4 "Streaming" Operating Mode.....	26
7.5 "Recording" Operating Mode	27
8 FIRMWARE UPDATE.....	28
9 RESET	28
PART 2: DRIVER SOFTWARE.....	29
1 GENERAL INFORMATION	29
2 INSTALLATION INSTRUCTIONS	29
2.1 Windows.....	29
2.2 Linux	29
3 OVERVIEW	29
3.1 Establishing Communication.....	29
3.2 Configuration of Data Packets.....	29
3.3 Polling Mode	30
3.4 Soft Real-Time Mode.....	30
3.5 Streaming Mode.....	30
3.6 Recording Mode.....	30
4 DATA TYPES	31
4.1 Simple Data Types.....	31
4.2 EnDat Additional Datum	31
4.3 Information for TCP Connection.....	31
4.4 Configuration for Data Packet	31
5 PARAMETERS AND RETURN CODES	31
6 AUXILIARY FUNCTIONS	32
6.1 Determining the IP Address.....	32
6.2 Changing the Position Data Format.....	32

7 DEVICE FUNCTIONS	33
7.1 Opening a Connection to the EIB 74x	33
7.2 Closing the Connection to the EIB 74x	34
7.3 Polling the Connection Status.....	34
7.4 Setting Up Timeout	34
7.5 Reading Out the Number of Axes	35
7.6 Requesting Handle for Axis	35
7.7 Requesting IO Port Handle.....	35
7.8 Creating a Data Packet	36
7.9 Configuring a Data Packet	36
7.10 Selecting the Operating Mode	37
7.11 Saving Network Parameters.....	37
7.12 Reading out the Network Parameters.....	38
7.13 Saving the Host Name	38
7.14 Reading out the Host Name	39
7.15 Reading out the Serial Number.....	39
7.16 Reading out the Device ID.....	39
7.17 Reading out the MAC Address.....	40
7.18 Reading out the Firmware Version Number	40
7.19 Reading out the Boot Mode.....	41
7.20 Reading out the Update Status.....	41
7.21 Reading the Number of Open Connections.....	41
7.22 Reading out the Connection Data	42
7.23 Terminating the Connection.....	42
7.24 Reading the Time Unit Timestamp	42
7.25 Setting the Timestamp Period Duration.....	43
7.26 Resetting the Timestamp Counter.....	43
7.27 Reading the Timer-Trigger Time Unit	43
7.28 Setting the Timer Trigger Period Duration.....	43
7.29 Reading the Time Unit for the Delay Time at the Trigger Inputs.....	44
7.30 Clearing the Trigger Counter	44
7.31 Software Trigger.....	44
7.32 Selecting the Master Trigger Source	45
7.33 Activating Trigger Sources	46
7.34 Configuring the Pulse Counter	47
7.35 Setting the Interpolation Factor for the Interval Counter	48
7.36 Configuring the Interval Counter	49
7.37 Setting the Terminating Resistors.....	49
7.38 Reset	50
7.39 Identifying the EIB 74x	50
7.40 Transferring the Recording Data	51
7.41 Verifying the Recording Status.....	51
7.42 Reading the Recording Memory Size.....	52
7.43 Checking the Streaming Status	52
7.44 Reading Data from the FIFO	53
7.45 Reading the Size of a FIFO Element	53
7.46 Access to the Contents of a FIFO Element	54
7.47 Reading and Converting Data from the FIFO	55
7.48 Reading the Size of a FIFO Element Following Conversion.....	55
7.49 Access to the Contents of a FIFO Element with Converted Data.....	56
7.50 Reading the Number of Elements in the FIFO.....	56
7.51 Clearing the FIFO	57
7.52 Setting the FIFO Size.....	57
7.53 Reading the FIFO Size	57
7.54 Activating the Callback Mechanism.....	58
7.55 Selecting the Trigger Source for the Auxiliary Axis	59
7.56 Reading the Position of the Auxiliary Axis.....	59
7.57 Reading Out the Data of the Auxiliary Axis.....	60
7.58 Clearing the Counter of the Auxiliary Axis.....	60
7.59 Acknowledging the Signal Errors of the Auxiliary Axis.....	60
7.60 Acknowledging the Trigger Errors of the Auxiliary Axis.....	61
7.61 Clearing the Status Bit for the Reference Mark of the Auxiliary Axis.....	61
7.62 Checking the Status of the Reference Run for the Auxiliary Axis.....	61

7.63	Starting a Reference Run for the Auxiliary Axis	61
7.64	Stopping a Reference Run for the Auxiliary Axis.....	62
7.65	Configuring a Timestamp for the Auxiliary Axis.....	62
7.66	Setting the Trigger Edge for the Reference Pulse of the Auxiliary Axis.....	62
8	AXIS FUNCTIONS	63
8.1	Initializing the Axis.....	63
8.2	Selecting the Trigger Source for the Axis	66
8.3	Setting the Trigger Edge for the Reference Pulse	66
8.4	Clearing the Counter	67
8.5	Interrogating a Position	67
8.6	Reading out Data for a Channel	68
8.7	Acknowledging the Power Supply Error	68
8.8	Acknowledging the Trigger Error.....	69
8.9	Acknowledging the Signal Error	69
8.10	Clearing EnDat Error Bits.....	69
8.11	Clearing Status Bits for Reference Marks.....	70
8.12	Clearing Status Bits for Distance-Coded Reference Marks.....	70
8.13	Starting the Reference Run.....	70
8.14	Stopping the Reference Run.....	71
8.15	Verifying the Status of the Reference Run.....	71
8.16	Activating the Monitoring of the Reference Marks	71
8.17	EnDat 2.1: Reading the Position	72
8.18	EnDat 2.1: Selecting the Memory Area.....	72
8.19	EnDat 2.1: Sending Data	73
8.20	EnDat 2.1: Receiving Data.....	73
8.21	EnDat 2.1: Resetting the Encoder.....	74
8.22	EnDat 2.1: Reading the Test Value.....	74
8.23	EnDat 2.1: Sending Test Command to Encoder.....	75
8.24	EnDat 2.2: Reading the Position and Additional Datum.....	75
8.25	EnDat 2.2: Reading the Position and Additional Datum and Selecting the Memory Area.....	76
8.26	EnDat 2.2: Reading the Position and Additional Datum and Sending Data	76
8.27	EnDat 2.2: Reading the Position and Additional Datum and Receiving Data.....	77
8.28	EnDat 2.2: Reading the Position and Additional Datum and Sending the Test Command.....	77
8.29	EnDat 2.2: Reading the Position and Additional Datum and Transmitting the Error Reset.....	78
8.30	EnDat 2.2: Selecting the Additional Datum	79
8.31	EnDat 2.2: Selecting the Sequence for Additional Datum	80
8.32	Reading Absolute and Incremental Position Values Simultaneously	81
8.33	Setting the Power Supply for Encoders	81
8.34	Reading the Power Supply Status for Encoders.....	82
8.35	Configuring the Timestamp.....	82
9	IO FUNCTIONS.....	83
9.1	Configuring the Input Port	83
9.2	Configuring the Output Port	84
9.3	Selecting the Trigger Source for the Trigger Output	84
9.4	Setting the Delay Time for the Trigger Input	85
9.5	Reading Out a Logical Port	85
9.6	Setting the Logical Output Port	86
9.7	Reading the Configuration Data for an Input	86
9.8	Reading the Configuration Data for an Output.....	87
10	GENERAL FUNCTIONS.....	88
10.1	Reading the Driver ID Number	88
10.2	Converting an Error Message into Text.....	88

Documentation

The documentation for the EIB 741 and EIB 742, hereafter referred to as EIB 74x, comprises the following documents:

- Commissioning Instructions:
 - Documents required for commissioning, as well as technical specifications.
- User's Manual:
 - Description of features on the EIB 74x.
 - Description of the installation and function calls of the driver software.

Firmware version

This document describes Firmware version: 633281-10

Change history

Changes from the previous versions are listed in the change history.

The document on change history is on the CD in the subdirectory EIB_74x/doc. Please read this document, in particular the notes on new, changed or obsolete function calls.

Part 1: Features

1 General Description of Function

The EIB 74x is an external interface box for precise position measurement. It is ideal for inspection stations and multipoint inspection apparatuses as well as for mobile data acquisition, such as in machine inspection and calibration.

The EIB 74x is ideal for applications requiring high-resolution encoder signals and fast data logging. Ethernet transmission also enables you to use switches or hubs for connecting more than one EIB 74x.

A maximum of four HEIDENHAIN encoders, either with sinusoidal incremental signals (1 V_{PP}) or with EnDat interfaces (EnDat 2.1 and EnDat 2.2) can be connected to the EIB 74x.

The EIB 74x subdivides the periods of the incremental signals 4096-fold for measured-value generation. The deviations within one signal period are automatically reduced by adjusting the sinusoidal incremental signals (signal compensation). The integrated measured-value memory enables the EIB 74x to save up to 250,000 measured values per axis in "recording mode." Internal or external triggers can be used for axis-specific storage of the measured values. A standard Ethernet interface using TCP or UDP communication is available for data output. This permits direct connection to a PC, laptop or industrial PC.

The method of measured value transmission can be set via the operating mode. Driver software for Windows, Linux and LabVIEW is included in the items supplied, in order to process the measured values on the PC. The driver software facilitates programming of customer applications. It also contains program examples demonstrating the performance range of the EIB 74x.

Basic circuit diagram

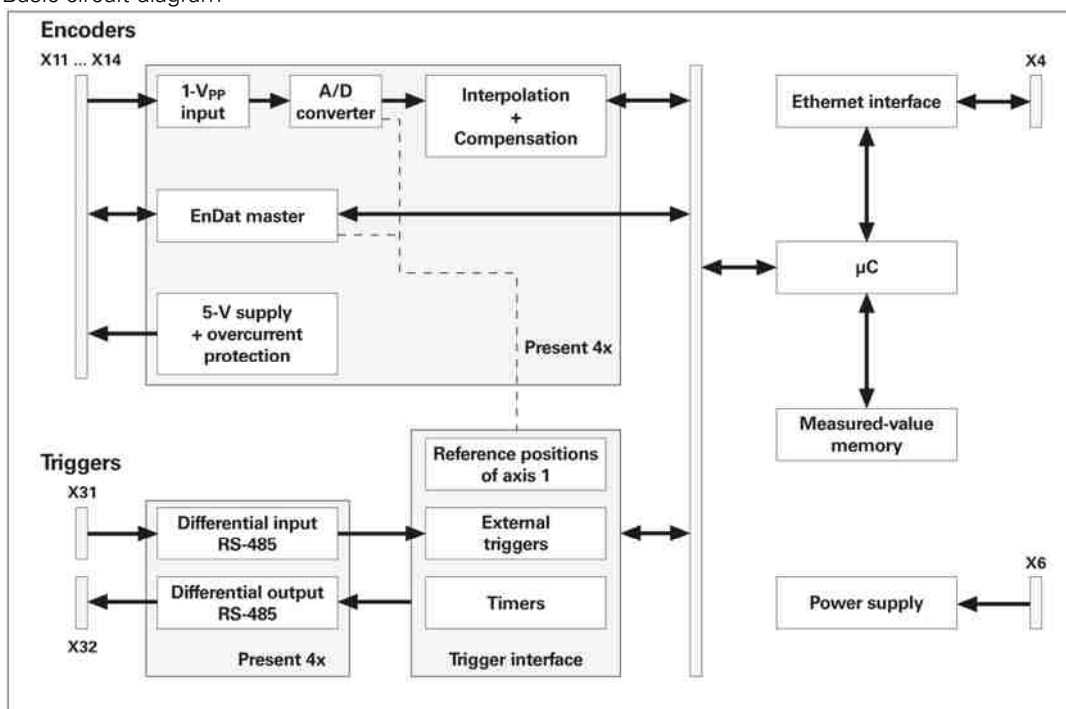

Encoder inputs:

A maximum of four HEIDENHAIN encoders with the following interfaces (freely programmable) can be connected to the EIB 74x:

- Incremental signals 1 V_{PP}
- EnDat 2.1
- EnDat 2.2
- Incremental signals 1 V_{PP} (upon request)

The power supply to the encoders is provided by the EIB 74x and is protected by a resettable overload cutout. For technical specifications, see "Commissioning Instructions."

2 Configuration of the Encoder Inputs

After power-up, the power supply to the encoders is activated. The other parameters for operating the encoder input must be configured by initialization.

- Interface type
- Bandwidth for the 1 V_{PP} input signals
- Signal compensation
- Processing the reference marks
- Processing the homing/limit signals

These settings can be changed via software.

The interface for the encoder input can be operated in incremental or EnDat mode. In EnDat mode, the incremental block can also be operated if, in addition to EnDat, the encoder also supports the 1 V_{PP} interface.

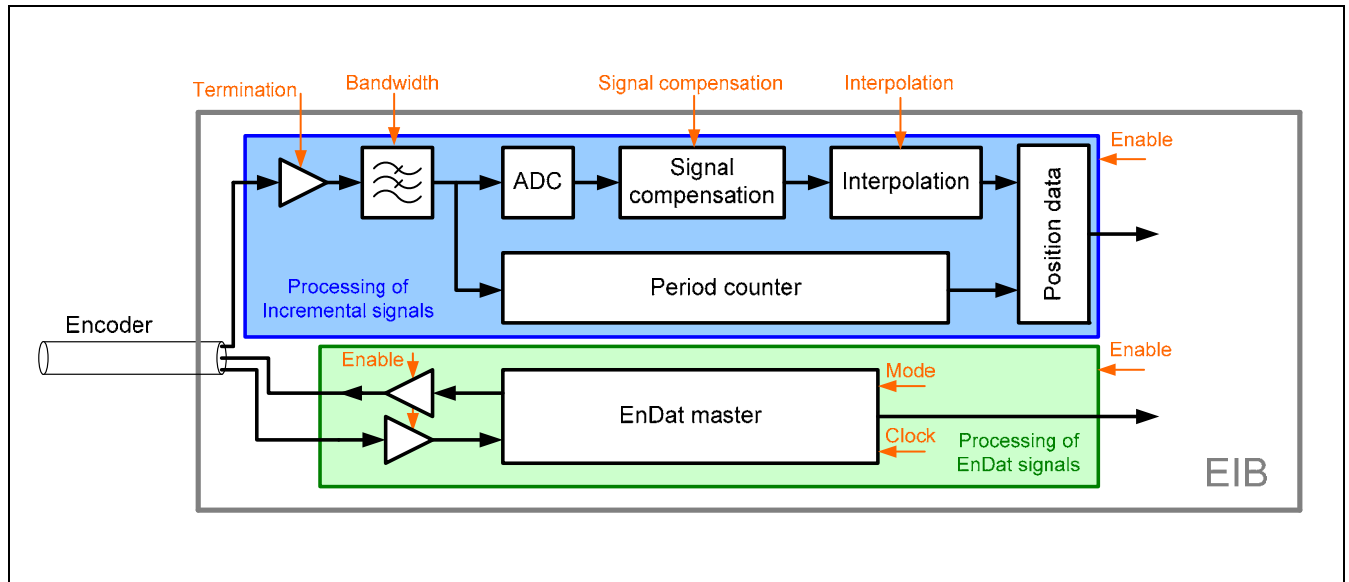

2.1 Processing Incremental Signals

The EIB 74x subdivides the periods of the incremental signals 4096-fold for position value generation (12 bits). The period counter has a width of 32 bits. The counter value is increased or decreased by the value "1" with each signal period of the connected encoder.

The deviations within one signal period are automatically reduced by adjusting the sinusoidal incremental signals (signal compensation). Compensation of the incremental encoder signals and the terminating resistor can be activated or deactivated by software.

The 44-bit wide position information at the time of the trigger event is formed from the interpolation value (12 bits) and the value of the period counter (32 bits). The position information is saved to a 48-bit wide register (see table). The period counter is mapped in the two's complement notation; bits 43 to 47 represent the sign.

Depending on the encoder type (linear or rotary), the higher-level customer software application can use this value to calculate the angle and length, respectively.

The period counter overflows according to the two's complement notation at the position: 0x07FF FFFF FFFF (maximum positive) → 0xF800 0000 0000 (maximum negative). This overflow does not affect the functionality of the period counter or the interpolator. The overflow, however, must be handled by the higher-level customer software application.

Bit no.	Width (bits)	Contents
0..11	12	Interpolation value
12..43	32	Period counter (bit 43 = sign)
44..47	4	Value identical to bit 43

Block diagram

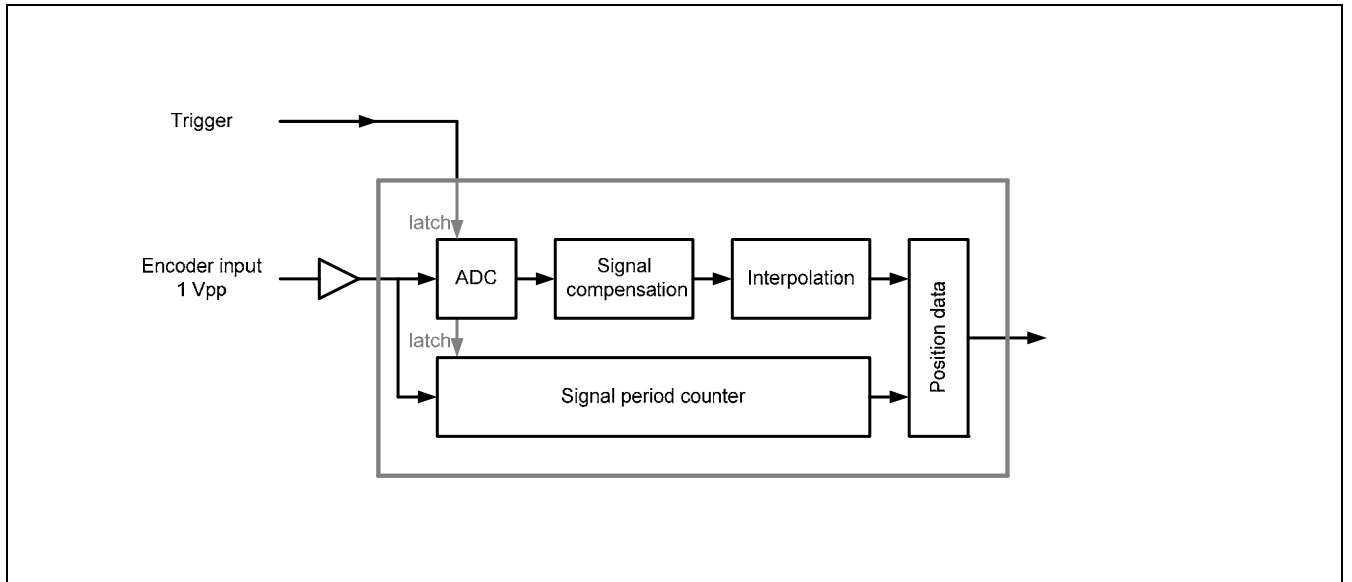

Interpolation value

At the time of the trigger event, the incremental signals are scanned and used to calculate a 12-bit wide interpolation value (not with the EnDat interface). The correlation between interpolation value and incremental signals is derived as follows:

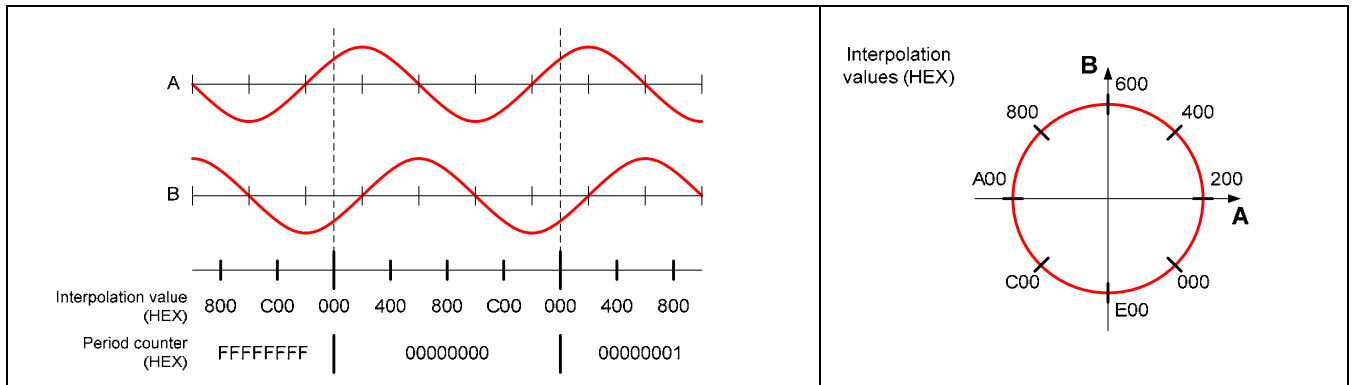

Setting options:

Terminating resistor for the incremental signals

The 120 ohm terminating resistor for the 1 V_{PP} incremental signals can be activated or deactivated (for all channels simultaneously; default: resistors activated) by software.

Bandwidth setting of the incremental signals

The bandwidth of the encoder's incremental signals can be toggled by software. The high bandwidth (500 kHz) should be set as default.

The low bandwidth (33 kHz) should only be selected for special applications.

Signal compensation

Compensation of the incremental encoder signals can be activated or deactivated by software.

2.2 Analog Values of the 1 V_{PP} Incremental Signals A and B:

The transmitted values correspond to the values of the AD converter at the time of the trigger event.

Bit no.	Width (bits)	Contents
0..11	12	12-bit AD converter value
12..15	4	Reserved

Value (HEX)	Incremental signal value
000	Negative maximum
800	Zero
FFF	Positive maximum

2.3 Dealing with Reference Marks

With incremental encoders, the reference mark/marks is/are used to generate an absolute reference for the incremental signals.

For encoders with one reference mark, this mark has an explicit reference to a specific signal period. This signal period can be used as a reference to generate absolute position values. Traversing the reference mark does not affect the period counter or the interpolation value. The period counter value valid at the time of traversing is simply saved in a register for the reference position. This value can be used in the customer software application to calculate absolute position values.

The figure below shows the general process of determining a reference position. The displayed values are only given as an example. To improve clarity, only a section of the position-value register is shown.

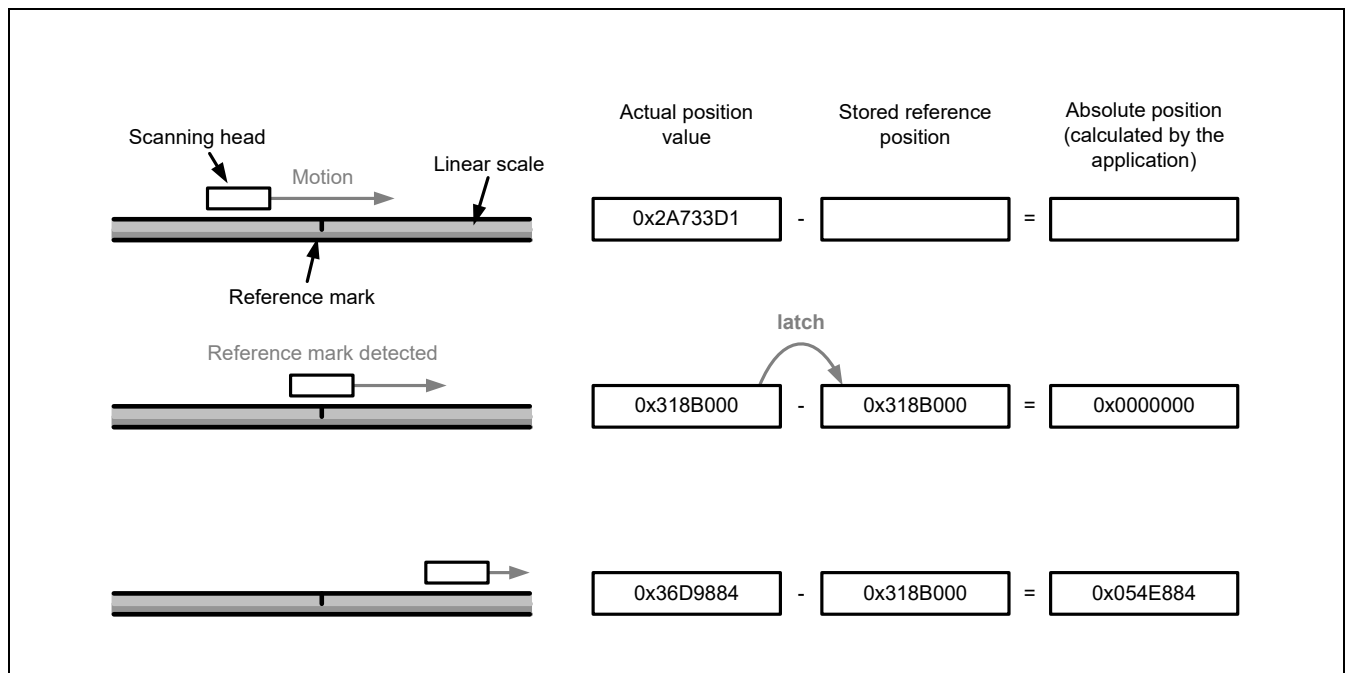

Register contents, reference position

Bit no.	Width (bits)	Contents
0..11	12	Always 0
12..43	32	Reference position (value of the period counter when the reference mark is detected; bit 43 = algebraic sign)
44..47	4	Value identical to bit 43

Automatic saving of the reference position must be activated by software. After this command, the EIB 74x waits for the next reference mark and then saves the reference position. You must activate this feature again if renewed saving is desired.

Normally, the reference position register is transmitted together with the position register and the status word in a shared position data packet after the next trigger event. During this process, the EIB 74x transmits two reference positions and, where applicable, the coded reference value:

- For encoders with one reference mark, reference position 1 is normally used.
- For encoders with distance-coded reference marks, either both register values are used or the coded reference value is used depending on the evaluation method.

Distance-coded reference marks

With distance-coded encoders, the reference for generating absolute position values from the counter values is obtained through the distance of two traversed (adjacent) reference marks.

For this purpose, the period counter value is saved twice, once each time a reference mark is traversed. The coded reference value is generated from the distance of the (adjacent) reference marks, and in doing so the reference for generating absolute position values is also created.

When the absolute position value is calculated by the customer software application, this value is treated exactly the same as a saved reference position value in the case of encoders with one reference mark (see drawing). The coded reference value thus corresponds to the offset between the absolute position value and the generated (incremental) position value.

There are various procedures for generating the coded reference value:

Method 1: (recommended method)

The axis is initialized as an incremental system with distance-coded reference marks. During this process, further type-dependent information about the measuring system is transferred to the EIB 74x. Once the reference positions have been saved successfully, the EIB 74x uses this information to automatically calculate the coded reference value. The saving process is started by software command (for two reference marks). After the second reference mark has been traversed, the EIB 74x automatically calculates the coded reference value and transfers it to the customer software application.

Method 2: (especially for applications with an extremely low traversing speed)

The axis is initialized as an incremental system with a simple reference mark. The customer software application sends the appropriate software command for saving the reference position (one reference mark). Each time the reference position has been saved successfully, the save process is activated again. This procedure must be repeated until two different reference positions have been measured. The customer software application can then calculate the coded reference value and hence the absolute position from these two values. It must be guaranteed that the customer software application can complete this procedure quickly and sufficiently, otherwise reference marks could be lost, resulting in an incorrect calculation of the absolute position.

Method 3:

The axis is initialized as an incremental system with a simple reference mark. The customer software application sends the appropriate software command for saving two reference positions. After both reference positions have been saved successfully (both reference position registers are used), the customer software application can calculate the coded reference value and hence the absolute position from these two values.

2.4 Monitoring the Reference Marks

The reference marks of an encoder can be monitored automatically. For this purpose, the reference position is saved and checked continuously. This results in the reference-position output being updated with each reference mark, and therefore can lead to a change in the reference position. The check varies slightly depending on the encoder, as described below. If an error occurs, a bit is set in the status word for the position.

Encoders with one reference mark:

For linear encoders with one reference mark, the position value at the reference mark must always be the same. The reference position is saved continuously and compared to the old value.

For rotary encoders with one reference mark, the position value at the reference mark may change if the encoder is moved in the same direction over one revolution. Two successively saved reference positions must be the same or may differ by the number of signal periods per revolution. The transmitted data packet always contains the current reference position.

Encoders with distance-coded reference marks:

For encoders with distance-coded reference marks, the coded reference position is recalculated continuously. The calculation always uses two adjacent reference positions as illustrated in the figure below. The transmitted data packet always contains the currently calculated reference position.

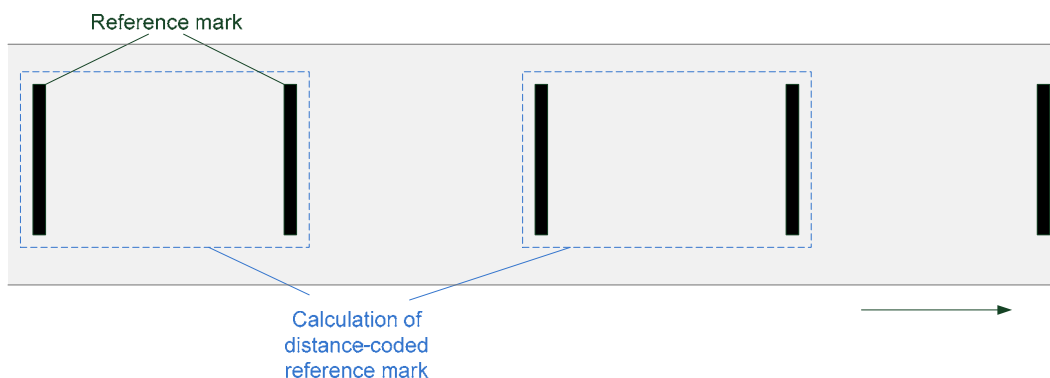

For linear encoders, the calculated reference position must always be the same. For rotary encoders, the calculated reference position may differ by the number of signal periods per revolution. If the same reference mark is traversed twice before and after a change in direction, the distance-coded reference mark cannot be calculated. No check takes place in this case. This must be taken into account especially for very small movements across a reference mark.

No reference run can be performed while monitoring of the reference marks is active, because this could lead to an incorrect error message in the monitoring process. The following sequence is recommended:

- Configuring the axes
- Performing the reference run
- Activating the monitoring of the reference marks

2.5 Processing EnDat Signals

HEIDENHAIN absolute encoders are available with EnDat 2.1 or EnDat 2.2 interface. Especially in the case of EnDat 2.1 encoders, 1 V_{PP} incremental signals are transmitted along with the EnDat signals. The EIB 74x is able to process all EnDat encoders with EnDat 2.1 or EnDat 2.2 interface both serially and also with 1 V_{PP} incremental signals.

The EnDat Master is set up individually when the axis is initialized:

- EnDat 2.1 or EnDat 2.2 communication can be set.
- The clock frequency for EnDat communication can be set.
- Delay compensation (EnDat 2.2) can be activated or deactivated.
- The recovery time I can be set if the encoder supports it.
- The monitoring of the calculation time can be set.

Notes on EnDat 01:

- If EnDat position polls and 1 V_{PP} incremental signals are used at the same time, only EnDat 2.1 mode commands can be sent to the encoder (axis must be configured for EnDat 01).
- The EnDat position can be imported only by a software command. Hence, the EnDat position and incremental position must be imported once (special command). Then an incremental position can be cyclically transferred.

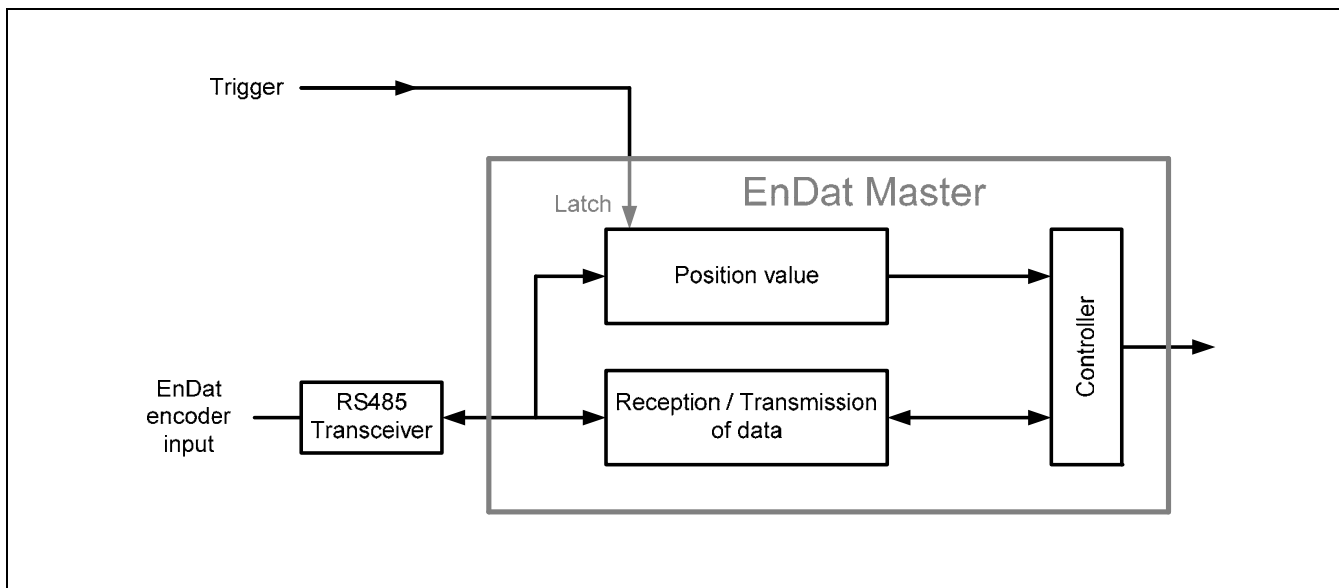

Position value register

The position register maps the position transmitted via the EnDat interface at the time of the trigger event. The position register for the EnDat position is 48-bits wide. The number of bits used for the position value depends on the connected EnDat encoder; the uppermost, unused bits must be masked out. See the encoder specifications for more detailed information.

Bit no.	Width (bits)	Contents
0..47	48	EnDat position value

EnDat clock frequency

The EnDat clock frequency can be set by a software command. The clock frequency can be set at specific intervals between 100 kHz and 6.66 MHz. The maximum permitted frequency is dependent on both the cable length between encoder and EIB 74x and also on whether delay compensation is activated.

Clock frequency parameter	Clock frequency	Comment
100000	100 kHz	
300000	300 kHz	Default with EnDat 2.1
500000	500 kHz	
1000000	1 MHz	
2000000	2 MHz	Default with EnDat 2.2
4000000	4 MHz	
5000000	5 MHz	
6666666	6.66 MHz	

Delay compensation

Delay compensation for the EnDat transmission can be activated or deactivated during axis configuration. Delay compensation is not approved by HEIDENHAIN for EnDat 2.1 encoders (exception: encoders with the ordering designation EnDat21). Delay compensation is approved by HEIDENHAIN for EnDat 2.2 encoders. This results in the following dependency of the maximum permitted EnDat clock frequency.

EnDat clock frequency	Cable length in meters	
	Without delay compensation	With delay compensation
100 kHz	150	100
300 kHz	150	100
500 kHz	100	100
1 MHz	55	100
2 MHz	10	100
4 MHz	–	50
5 MHz	–	40
6.66 MHz	–	25

Recovery time I

The recovery time I can be set for EnDat 2.2 encoders (ordering designation EnDat02 or EnDat22). Here there are two options—"long" ($10 \mu\text{s} < t_m < 30 \mu\text{s}$) and "short" ($1.25 \mu\text{s} < t_m < 3.75 \mu\text{s}$). For EnDat 2.1 encoders, the long recovery time I is always used.

Notes on setting the short recovery time I:

- The default setting is "long."
- The short setting is chosen in order to attain shorter cycle times during EnDat transmission.
- For the short setting, the EnDat clock frequency must be set to > 1 MHz at the same time.

Calculation time

The calculation time indicates the time for position formation in the encoder and therefore affects the duration of the position request. In order to monitor the communication a timeout is generated if the position request exceeds a certain duration.

This is displayed in the status word as an error. If the calculation time was set too short, this error message can appear even though the encoder transmitted the data correctly. Conversely, an excessively long calculation time can cause an undesired delay in the error message. At high trigger rates, in particular, the error message can be offset by several samples.

The calculation time can be set to depend on the connected encoder. Two options are supported:

Long The calculation time of the encoder is < 1 ms

Short The calculation time of the encoder is $< 15 \mu\text{s}$

Notes:

- The default setting is "long."
- For the short setting, the EnDat clock frequency must be set to > 1 MHz at the same time.

EnDat 2.2 additional data

The EnDat 2.2 additional data can be transmitted in various ways in the Soft Real-Time, Streaming, and Recording operating modes.

1) No additional datum

A position request is started with each trigger event. Additional data is not transmitted.

2) Fixed additional data

Besides the position value, with each trigger event one piece of fixed information is sent as additional datum 1 and additional datum 2. This has to be set before activation of the corresponding operating mode. It can only be changed in the Polling mode of operation. It is also possible to transmit only additional datum 1 or additional datum 2.

3) Variable additional data

The additional data is switched in cycles. The EIB 74x features a ring buffer with 10 entries for setting the additional data, which is executed cyclically. The position value and the additional data 1 and 2 are transmitted with each trigger event. In addition, the EnDat 2.2 transmission supplement is transmitted, over which a new additional datum is selected based on the data in the ring buffer. The additional data 1 and 2 can be mixed in the ring buffer. Only one of the two additional data can be switched over per position request.

Processing additional incremental signals with EnDat

If, with EnDat encoders, the incremental signals are used for position formation, an absolute reference can be created by saving the EnDat position and the incremental position simultaneously. To do this, a special command is sent to the EIB 74x via the customer software application, which then generates an internal trigger signal. This trigger signal initiates simultaneous position determination via the EnDat interface and via the incremental signals. Both positions are transmitted to the customer software application as a return code.

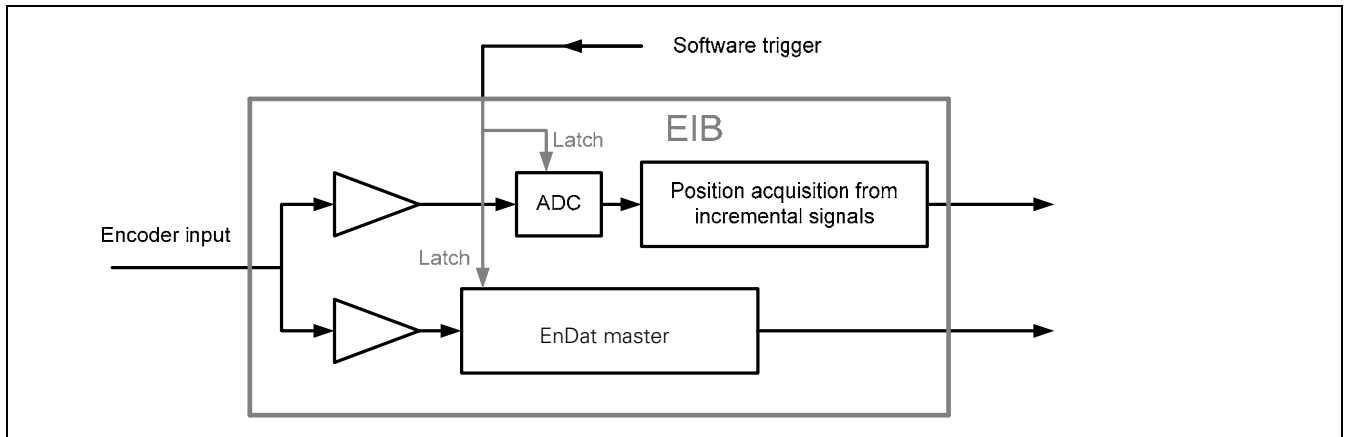

Note:

The interpolation zero points for the incremental signals and the EnDat position are different and must also be taken into account by the customer software application.

Furthermore, any differing resolution between EnDat and incremental position must also be taken into account.

Incremental signals: see "Processing incremental signals" section for interpolation zero point

EnDat Position: see graphic for interpolation zero point

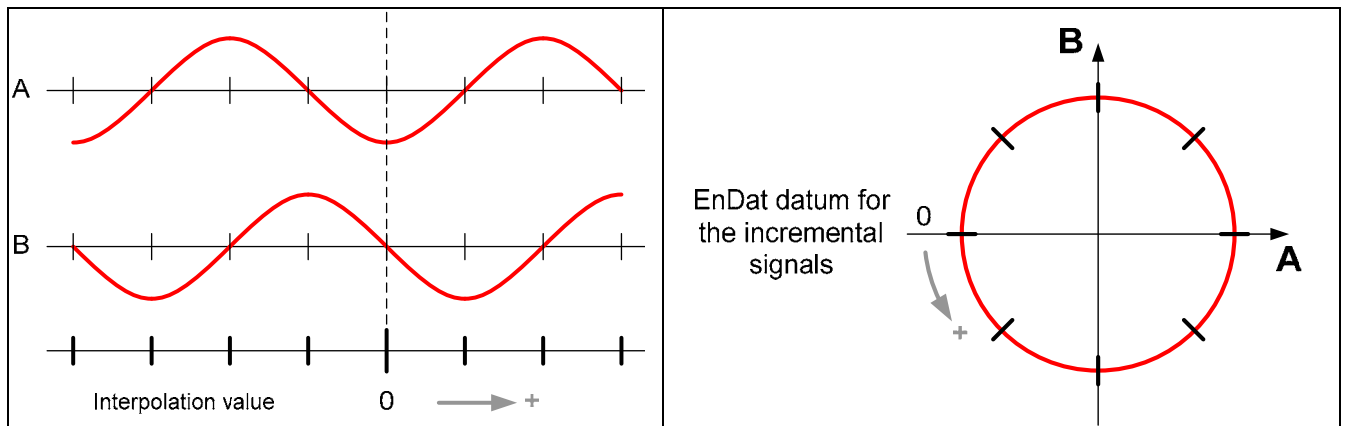

2.6 Auxiliary Axis

The auxiliary axis is coupled to axis 1 and can be used for encoders with 1 Vpp interface. The signals of axis 1 are interpolated and forwarded to a position counter. The interpolation factor can be set at specific intervals. Edge evaluation (1-fold, 2-fold or 4-fold) can also be selected. The maximum permissible input frequency of the encoder signals for the interpolator depends on the interpolation factor and is shown in the table below. In order not to limit the input frequency unnecessarily, the edge evaluation should be set to 4-fold (4x), and therefore a low interpolation factor should be selected. For example, a 5-fold interpolation factor with 4-fold edge evaluation results in the same increment as a 20-fold interpolation factor with 1-fold edge evaluation, but the maximum permissible input frequency is higher.

Linear encoder:

$$\frac{\text{Increment}}{\mu\text{m}} = \frac{\text{Signal period of encoder} / \mu\text{m}}{\text{Interpolation factor} \cdot \text{Edge evaluation}}$$

Rotary encoder:

$$\frac{\text{Increment}}{1^\circ} = \frac{\frac{360^\circ}{\text{Line count of encoder}}}{\text{Interpolation factor} \cdot \text{Edge evaluation}}$$

Interpolation factor	Max. input frequency in kHz
1-fold	500
2-fold	500
4-fold	500
5-fold	500
10-fold	400
20-fold	200
25-fold	160
50-fold	80
100-fold	40

Besides the position value, a timestamp and a reference position are available to the auxiliary axis. The status word for the auxiliary axis contains status and error messages. Both the position value and the reference position are 32-bit values. The number of counting steps per signal period of the encoder depends on the interpolation factor for the auxiliary axis. The position value is represented as a two's complement number. According to this, it overflows at the position: 0x7FFF FFFF (maximum positive) → 0x8000 0000 (maximum negative). Any overflow must be handled by the higher-level customer software application.

Bit no.	Width (bits)	Contents
0..31	32	Position value of the auxiliary axis (bit 31 = sign)

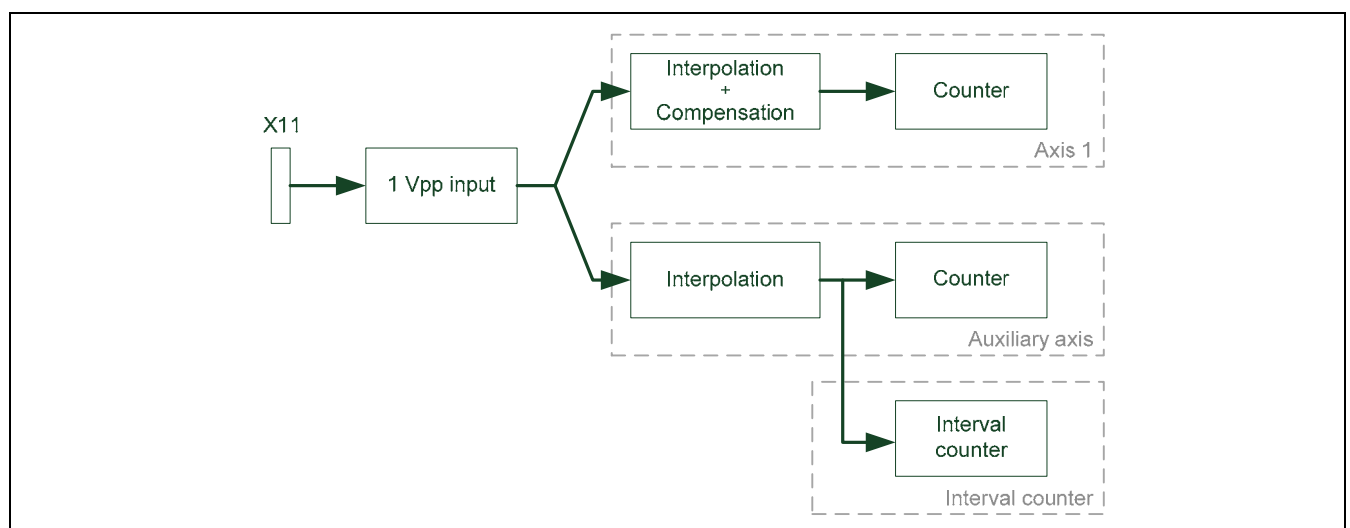

3 Processing of Trigger Events

Position value determination inside the EIB 74x is initiated via a so-called trigger event. The EIB 74x supports the following trigger sources:

- 4 external trigger inputs
- Internal periodic trigger source, timer-controlled
- Software command
- Reference pulse of the encoders
- Position trigger (interval counter)

The trigger source must be set by software command for each axis; only one trigger source per axis can be active at the same time. However, it is possible to activate different trigger sources for different axes. Also, one trigger source must be defined as the master trigger source that defines the time of data transmission. For all axes triggered by the master trigger source, a new position is transmitted in each data packet. For all other axes, a valid position is transmitted only if a trigger event also occurred for the respective axis. Otherwise, the position value is marked as invalid.

Not all trigger interface options are supported in all operating modes; see "Operating Modes" section for details.

3.1 Trigger Inputs and Outputs

Four trigger inputs and/or outputs are supported. For technical specifications on the trigger input, see "Commissioning Instructions."

Trigger inputs

Synchronize the position requests on external events; please also note the information provided in Chapter 3.5.

The 120 ohm terminating resistor can be activated or deactivated by configuration.

Trigger outputs

The trigger outputs forward trigger events, e.g. to other EIB 74x units. This permits the generation of a trigger chain, which synchronizes multiple EIB 74x units with an external trigger event. The various EIB 74x units must be configured separately by software commands. The position data is sent via the respective Ethernet connection. To generate a trigger chain, the following connection between the EIB 74x units must be used:

- Trigger Out + → Trigger In +
- Trigger Out – → Trigger In –
- GND to GND

A pulse at the trigger output is 2 μ s long and is generated synchronously with the system clock of the EIB 74x. The trigger event corresponds to the rising edge of the pulse. If a signal is forwarded from the trigger input to the output, it is affected by jitter due to the synchronization with the system clock. In order to avoid this jitter, it is possible to switch the signal at the trigger input directly to the corresponding trigger output.

The trigger signals can be fed through from the input to the output separately for each channel. Input 1 can be connected to output 1, and so on. The trigger input and the corresponding output are shown in the figure below.

Note:

The differential signals "Trigger Out +" and "Trigger Out –" can be swapped in order to change the polarity of the signal at the trigger output. Accordingly, the output "Trigger Out –" must be used for single-ended signals (see instructions for installation/commissioning).

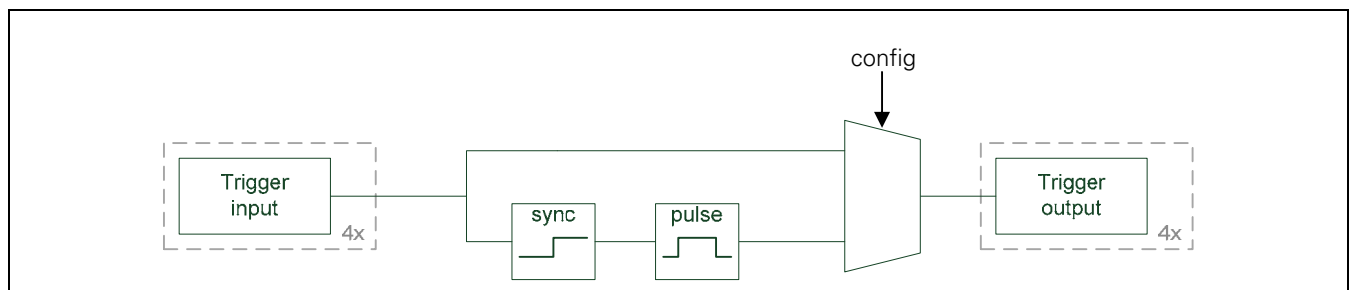

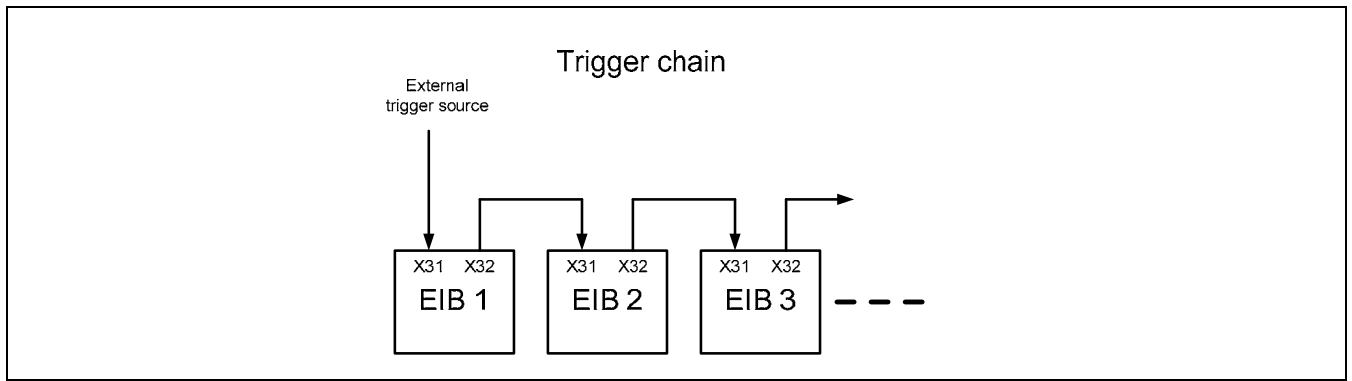

Configuring the trigger inputs and outputs as logical inputs and outputs

The trigger inputs/outputs can also be used as logical inputs/outputs. Trigger inputs and/or outputs are set by default. The ports can be individually configured as logical inputs and outputs or as trigger inputs and outputs by a software command. It is not possible to use them simultaneously as trigger inputs/outputs and logical inputs/outputs.

3.2 Logical Inputs and Outputs

Logical inputs

Each trigger input can be individually converted to a logical input. The level of the corresponding input can be read by a software command. The 120 ohm terminating resistor can also be activated or deactivated in this mode by configuration.

Logical outputs

Each trigger output can be individually converted to a logical output. The output level can also be read back. The outputs can be individually activated or deactivated, irrespective of the configuration.

The graphic below shows the trigger input and output options at a glance. Only one channel is shown.

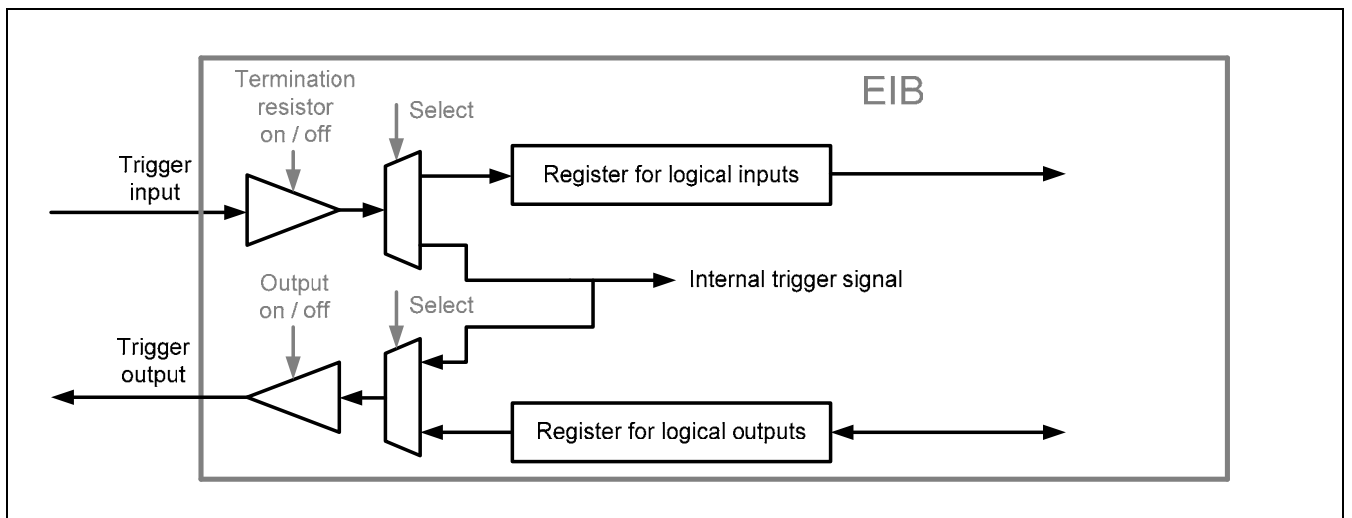

3.3 Trigger Module

The trigger module enables you to select and control the trigger sources. Furthermore, it generates internal trigger signals. You can delay external trigger signals; the delay time can be set for each input separately. The reference pulse of an encoder with 1 Vpp interface can be used for the associated axis as a trigger source. In addition, the reference pulse of axis 1 is gated with the signals A and B of axis 1 by logic AND, and can be used as a trigger signal for any axes. The active edge of the reference signal can be set in each case. If the reference pulse is selected as the trigger source for more than one axis, each axis is triggered with its own reference pulse. If the reference pulse is also selected as the master trigger source in this case, a reference pulse must occur on each axis before transmitting the data packet. Furthermore, there are four freely assignable channels for software triggers.

The interval counter generates trigger signals depending on the position of the encoder on axis 1. A signal period of the encoder can be divided into several counting steps via an adjustable interpolator. The triggering occurs either at a certain position or at equidistant intervals.

The pulse counter is not a separate trigger source; it allows you to limit the number of trigger pulses of other sources. A selectable trigger source can supply pulses that are disabled until the gate is opened by the start signal. All trigger pulses are then counted, and the gate is closed again after a selectable number of pulses. Besides, it is possible to reload the counter while the gate is open. The number of trigger pulses can be increased in this way.

The switch matrix makes it possible to connect the trigger sources individually to the sinks, such as trigger outputs or axes. However, not all sources can be connected to all sinks. The following table provides an overview of the possible combinations: Only one trigger source is permissible per sink. For the pulse counter, there is a trigger signal whose trigger pulses are controlled via the internal gate. The start signal opens the gate for the trigger pulses.

Trigger source	Trigger output	Axis	Auxiliary axis	Pulse-counter trigger	Pulse-counter start
Trigger input	x	x	x	x	x
Reference pulse	–	x	x	x	x
Masked reference pulse	x	x	x	x	x
Interval counter	x	x	x	x	x
Pulse counter	x	x	x	–	–
Software trigger	x	x	x	–	x
Timer	x	x	x	x	–

All trigger sources can be deactivated separately. This makes it possible to first configure the EIB 74x and then enable the trigger sources. Any combination of trigger sources can be enabled or disabled at the same time.

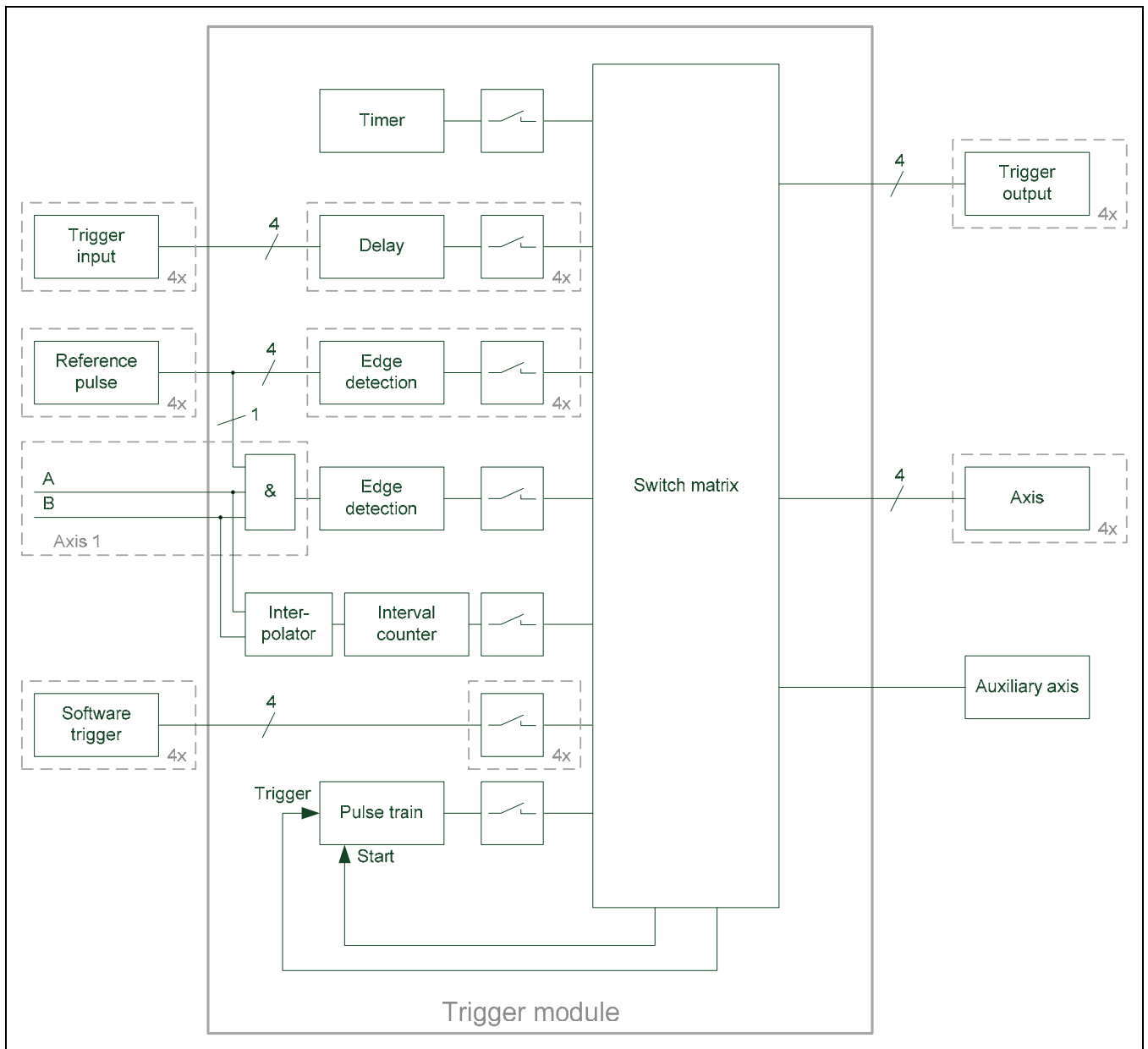

3.4 Interval Counter

The interval counter permits position-dependent triggering in connection with an incremental encoder on axis 1. The encoder signal can be interpolated (see "Auxiliary Axis" chapter).

The triggering occurs at a certain position, or equidistant trigger pulses with an adjustable position interval are generated. Output of the trigger pulses starts after an adjustable start position has been traversed, and is then continued at the position interval in both counting directions. The position interval ΔX must be specified in counting steps (for calculating the increment, see "Auxiliary Axis" chapter).

Hysteresis prevents multiple triggering, in particular if a high interpolation factor is used for the encoder signal. After a trigger pulse has been generated at a position, the value of the position counter must change by $+H$ or $-H$ before a new trigger pulse is generated at the same position.

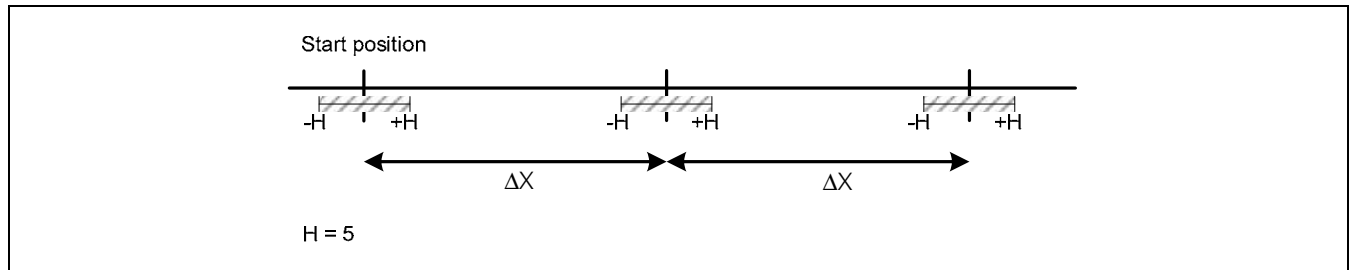

3.5 Maximum Trigger Rate

The maximum trigger rate of the EIB 74x depends on the set operating mode ("Polling" mode being an exception):

- Soft Real-Time mode: Max. 10 kHz
- Recording mode: Max. 50 kHz
- Streaming mode: Max. 50 kHz

Note:

In Streaming mode the data rate is additionally limited to 1 200 000 bytes/second. The data rate is product of the size of the data packet and the trigger rate.

$$\frac{\text{Size of data packet}}{\text{Byte}} \cdot \frac{\text{Trigger rate}}{\text{Hz}} \leq 1.200.000$$

Here it must be ensured that the data rate is not limited by the host on which the data are subsequently processed.

A certain interval, which the EIB 74x requires for the position calculation, must be respected between two trigger events. If this interval is not respected, i.e. the trigger rate is too high, trigger events cannot be accepted by the EIB 74x, and therefore are lost (lost trigger). This is detected by the EIB 74x and displayed in the status word of the position data packet by the "lost trigger" bit. This bit is set at "1" until actively reset by the customer software application using a clear command.

The values mentioned above apply if incremental signals are used. If the EnDat interface is used, the EnDat transmission time must be observed.

Caution:

If the maximum trigger rate is grossly exceeded (e.g. incorrect parameterization or too many events at the external trigger input), this may result in the EIB no longer reacting to external commands so that it cannot be addressed until a hard reset.

3.6 Counter for Accepted Trigger Events

In addition to monitoring for lost triggers, the EIB 74x has, for further error detection, a counter that is incremented by each incoming and accepted trigger event of the master trigger source. A trigger event is accepted if the above-mentioned interval is maintained. Trigger events that result in lost triggers are not counted. The counter value is transferred in the position data packet and can be monitored for continuity. This makes it possible to detect lost position data packets.

4 Timestamp

The "timestamp" function is also used to monitor data flow. The timestamp counter is a free-running timer with a freely programmable time interval. Each trigger event that results in a position value determination also causes the current timer value to be saved to the timestamp register. When the timestamp function is activated, the contents of this register are transmitted with the position data packet. This enables the customer software application to check whether the latch time of each individual position value corresponds to the expected value. In the case of applications that do not have a periodic trigger, the time of the trigger event can be transmitted with this register.

Note:

The time interval of the counter timestamp is a multiple of the internal system clock in the EIB 74x. Before the timestamp function can be used, the time interval has to be set by a software command. The "clock ticks per μs " value must first be read and the required time interval set in dependence of this value. This is necessary to keep the software compatibility independent of various settings for the system clock.

Note:

The following data must be transferred to the function to ensure that the value for a period (e.g. for the "period" parameter of the "EIB7SetTimestampPeriod" function call) is correctly calculated:

period = Time interval in μs * clock ticks per μs

The value for "clock ticks per μs " can be read out using the EIB7GetTimerTriggerTicks or EIB7GetTimestampTicks function, for example.

This note applies to the function call in Chapter 7.25, as well as for the calls in Chapter 7.28 (please also note Chapter 3.5) and Chapter 9.4.

5 Status Word

The status word must be interpreted depending on the poll type:

- Incremental position data
- EnDat position data
- Polling of EnDat additional data

The status word is transmitted separately for each encoder channel and does not depend on which operating mode is set.

Bit no.	Incremental position	EnDat position	EnDat additional datum	Auxiliary axis
0	1 = Valid position	1 = Valid position	1 = Valid additional datum	1 = Valid position
1	1 = Signal amplitude error	1 = CRC error	1 = CRC error	1 = Signal amplitude error
2	Reserved	Reserved	Reserved	Reserved
3	1 = Frequency exceeded	Reserved	Reserved	1 = Frequency exceeded
4	1 = Encoder power supply error	1 = Encoder power supply error	Reserved	1 = Encoder power supply error
5	1 = Fan error	1 = Fan error	Contents I0	1 = Fan error
6	Reserved	Reserved	Contents I1	Reserved
7	1 = Lost trigger	1 = Lost trigger	Contents I2	1 = Lost trigger
8	1 = Reference position 1 saved	1 = EnDat error message 1	Contents I3	1 = Reference position saved
9	1 = Reference position 2 saved	1 = EnDat error message 2	Contents I4	Reserved
10	1 = Coded reference value for distance-coded reference marks is valid	Reserved	EnDat busy bit	Reserved
11	1 = Error when calculating the coded reference value for distance-coded reference marks. Error while monitoring the reference marks	Reserved	EnDat RM Bit	Reserved
12	1 = Homing signal active	Reserved	EnDat WRN bit	Reserved
13	1 = Limit signal active	Reserved	Reserved	Reserved
14	Reserved	Reserved	Reserved	Reserved
15	Reserved	Reserved	Reserved	Reserved

Notes on the error bits

Name	Meaning
Valid position	1 → No error occurred This bit indicates whether the transmitted position is valid or not
Valid additional datum	1 → EnDat additional datum was received Otherwise, no additional datum has been selected or received
Signal amplitude error	1 → Signal amplitude of 1 V _{PP} incremental signals is and/or was too low (once or repeatedly since this error message was last cleared)
Frequency exceeded	1 → Excess input signal frequency has been detected (once or repeatedly since this error message was last cleared)
CRC error	1 → CRC error during EnDat data transmission
Encoder power supply error	1 → Power supply to the encoder was switched off automatically. (overcurrent fuse has tripped)
Fan error	1 → The EIB 74x fan has malfunctioned
Lost trigger	See "Maximum trigger rate" section
Reference position 1 saved	1 → Reference position 1 was saved (since the last corresponding software command)
Reference position 2 saved	1 → Reference position 2 was saved (since the last corresponding software command)
Coded reference value for distance-coded reference marks is valid	1 → Coded reference value for distance-coded reference marks was calculated successfully (since the last corresponding software command)
Error when calculating the coded reference value for distance-coded reference marks	1 → Error when calculating the coded reference value; must be reset explicitly. An error was detected during automatic monitoring of the reference marks. The error must be cleared explicitly.
Homing signal	1 → The homing signal (L1) is active at the time of the position request
Limit signal	1 → The limit signal (L2) is active at the time of the position request
EnDat error message 1	1 → Error message 1 active
EnDat error message 2	1 → Error message 2 active
EnDat Busy bit	1 → Busy bit is set
EnDat RM bit	1 → RM (reference mark) bit is set
EnDat WRN bit	1 → WRN (warning) bit is set
Contents I0 to I4	These five bits define the contents of the received additional datum. The customer software application requires this information to interpret the data.

The error bits are not reset automatically. They have to be reset by a software command from a customer software application. If an error is not reset, it will be re-transmitted with every subsequent position data packet.

With incremental encoders, an error in the position data packet indicates that the position is no longer valid and has lost any reference to reference marks or other measuring channels.

The occurrence of one error can initiate others. An error in the power supply to the encoder will initiate other errors. Any error in the power supply must therefore be reset first. Once the power supply is stable (delay of approx. 1.5 seconds), the other errors must be reset.

Lost trigger

The "lost trigger" bit indicates that at least one trigger event was processed incorrectly because the period between two trigger events was too short. The "lost trigger" bit can also occur if malfunctions superimpose the trigger line or EMC influences have a negative effect on the transmission. A "lost trigger" does not mean that the position values are false. It merely indicates that trigger events were unable to be processed correctly. The reset must also be done actively by a software command.

Reference position saved

The two "reference position 1 (2) saved" bits indicate that a valid reference mark has been detected and saved. This means the corresponding reference position in the position data packet is valid.

Coded reference value for distance-coded reference marks is valid

This bit is reset by sending the corresponding software command for saving reference positions. After the coded reference value has been calculated successfully, this bit is set to active. This means that the "coded reference value for distance-coded reference marks" transmitted in the position data packet can be used to calculate the absolute position.

Error in reference position for distance-coded reference marks

This bit is set if an error has occurred while the coded reference value for distance-coded reference marks is being calculated. One possible reason is that during the reference run, a change of direction has occurred, causing the same reference mark to be detected twice. The error must be actively reset. It is not reset automatically when the software command for saving reference positions is resent. Furthermore, this bit is set if automatic monitoring of the reference marks has been activated and an error has occurred. This also applies to encoders that are not distance-coded. The error must be cleared explicitly in this case, too.

Homing/ Limit signals

The homing/limit signal indicates whether the respective signal is active, should it be supported by the encoder. The state of the signal is not stored, and therefore does not need to be cleared.

Fan error

This bit indicates whether the fan of the EIB 74x is functioning correctly. The error bit does not influence the position data. The error bit is not saved and therefore does not have to be deleted. The bit is set as long as fan operation is faulty.

Note:

For additional information, see "Commissioning Instructions."
If the fan monitoring function is not supported, this bit is always set to 0.

6 Ethernet Interface

The Ethernet (LAN) interface is used for configuring the EIB 74x and for transmitting the position data packets. TCP commands are used for configuration whilst UDP packets are used for transmitting the data in Soft Real-Time mode. The settings of the PC firewall must be selected correspondingly. The network settings of the EIB 74x can be changed by means of the software commands. The IP address can either be permanently set or can be obtained dynamically from a DHCP server. For additional details, see "Commissioning Instructions."

7 Operating Modes

The EIB 74x supports the following operating modes:

- Polling
- Soft Real-Time
- Streaming
- Recording

7.1 Configuration of Data Packets

It is necessary to configure a data packet for the "Soft Real-Time," "Streaming" and "Recording" operating modes. Depending on this configuration, certain data is transmitted or recorded with each trigger event. This makes it possible to limit the quantity of data to the elements actually required. This reduces the required transmission capacity and the memory space needed in the Recording mode.

A data packet is divided into several regions. Each region contains the data for a certain axis of the EIB 74x or global information. The global information must always be contained in the data packet as the first region. Then one or more regions can follow for the axes. Axes can be omitted here; however they must be contained in ascending order in the data packet. The example "InfoGlobal-axis1-axis3-axis4" is a valid data packet, but not "InfoGlobal-axis1-axis4-axis3". If the auxiliary axis is used, the auxiliary axis must be the last region in the data packet.

Different data elements can be contained within any region. All possibilities are listed in a table below. The length indicates the number of bytes for the data element. The sum of all elements from all regions is the size of the data packet. However, the length of a data packet must always be a multiple of 4 bytes. If this is not complied with in a certain configuration, the required "fill bytes" are automatically appended.

Global information

Data element	Description	Length in bytes
Trigger counter	Counter for trigger events	2

Axis

Data element	Description	Length in bytes
Status word	Status and error messages	2
Position value	Current position value of the encoder	6
Timestamp	Timestamp for position value	4
Reference position	Position value for reference marks	12
Coded reference position for distance-coded reference marks	Calculated reference position for distance-coded reference marks	6
Amplitude value of incremental signal	Bytes 0 and 1: Signal A Bytes 2 and 3: Signal B	4
EnDat additional datum 1	Bytes 0 and 1: Status word Bytes 2 and 3: Additional datum	4
EnDat additional datum 2	Bytes 0 and 1: Status word Bytes 2 and 3: Additional datum	4

Auxiliary axis

Data element	Description	Length in bytes
Status word	Status and error messages	2
Position value	Current position value of the encoder	4
Timestamp	Timestamp for position value	4
Reference position	Position value for reference mark	4

The following example illustrates the configuration of a data packet for two axes. In addition, a region is inserted for the global information.

- Global information: Trigger counter
- Axis 1: Incremental interface (1 V_{PP})
One reference mark
- Axis 2: Incremental interface (1 V_{PP})
One reference mark

Packet configuration:

Region	Element	Length in bytes
Global	TriggerCounter	2
Axis1	Status word	2
	Position value	6
	Timestamp	4
	Reference position	12
Axis2	Status word	2
	Position value	6
	Timestamp	4
	Reference position	12
	Fill bytes	2

This results in a total length of 52 bytes for the data packet.

After the device is switched on, the EIB 74x loads a default configuration for the data packet. This configuration comprises the global information and one region each for all four axes. The following table shows the composition of the data packet.

Region	Element	Length in bytes
Global	TriggerCounter	2
Axis1	Status word	2
	Position value	6
	Timestamp	4
	Reference position 1	6
	Reference position 2	6
	Coded reference value for distance-coded reference marks	6
	Amplitude value of incremental signal	4
Axis2	Status word	2
	Position value	6
	Timestamp	4
	Reference position 1	6
	Reference position 2	6
	Coded reference value for distance-coded reference marks	6
	Amplitude value of incremental signal	4
Axis3	Status word	2
	Position value	6
	Timestamp	4
	Reference position 1	6
	Reference position 2	6
	Coded reference value for distance-coded reference marks	6
	Amplitude value of incremental signal	4
Axis4	Status word	2
	Position value	6
	Timestamp	4
	Reference position 1	6
	Reference position 2	6
	Coded reference value for distance-coded reference marks	6
	Amplitude value of incremental signal	4

7.2 "Polling" Operating Mode

This operating mode is activated by default after the EIB 74x is initialized. The position data is determined in the EIB 74x as soon as a corresponding command is received. The EIB 74x transmits the data inside the response packet to the customer application.

The diagram below illustrates the sequence of a position poll. A command is sent to the EIB 74x from a customer software application on the PC. The EIB 74x generates the position data and returns it in a TCP packet. The data is transmitted to the application.

Processing trigger events:

- The time of position value formation is influenced by the software and cannot therefore be determined exactly.
- Only software triggers are used for triggering.

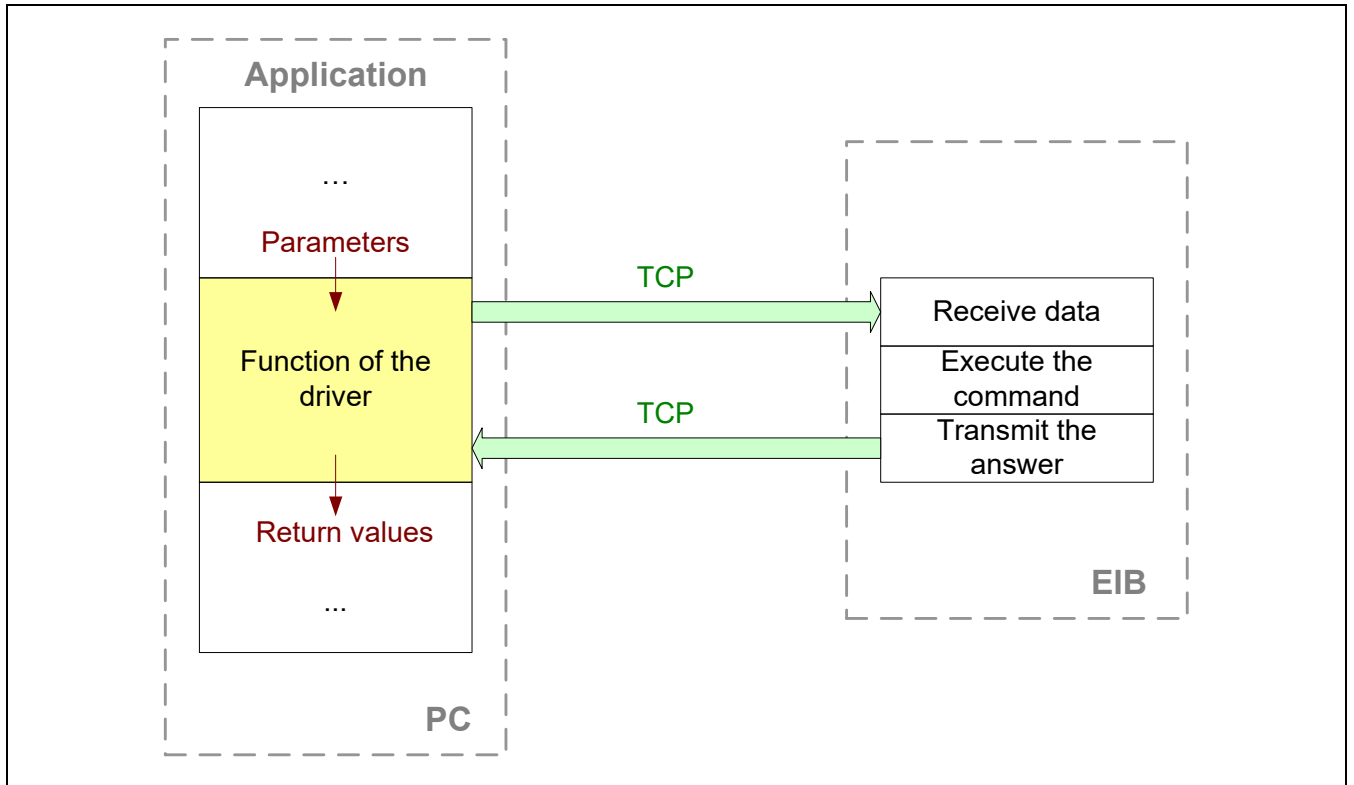

Data packets in "Polling" mode:

Dependent upon the selected function; see chapters containing function calls.

7.3 "Soft Real-Time" Operating Mode

The position data is transported with UDP packets from the EIB 74x to the PC. This occurs parallel to the TCP communication via the standard Ethernet interface. The position data is generated when the EIB 74x receives a trigger signal. With each trigger event, a data packet is sent to the PC automatically. Here, the packets can be read from a FIFO.

For operation in Soft Real-Time mode, the EIB 74x must be configured following the steps listed below.

- Initialization of the EIB 74x
- Initialization and configuration of the axes
- Configuration of the data packet
- Configuration of the trigger logic
- Selection of the operating mode (Soft Real-Time)
- Activation of the trigger source

The diagram below illustrates the communication process schematically. The customer software application has to configure the EIB 74x. The data is then transmitted to the FIFO independently. From here, the application can read out the data within a program loop.

Parallel to the position poll, the status of the EIB 74x can be requested or error messages cleared.

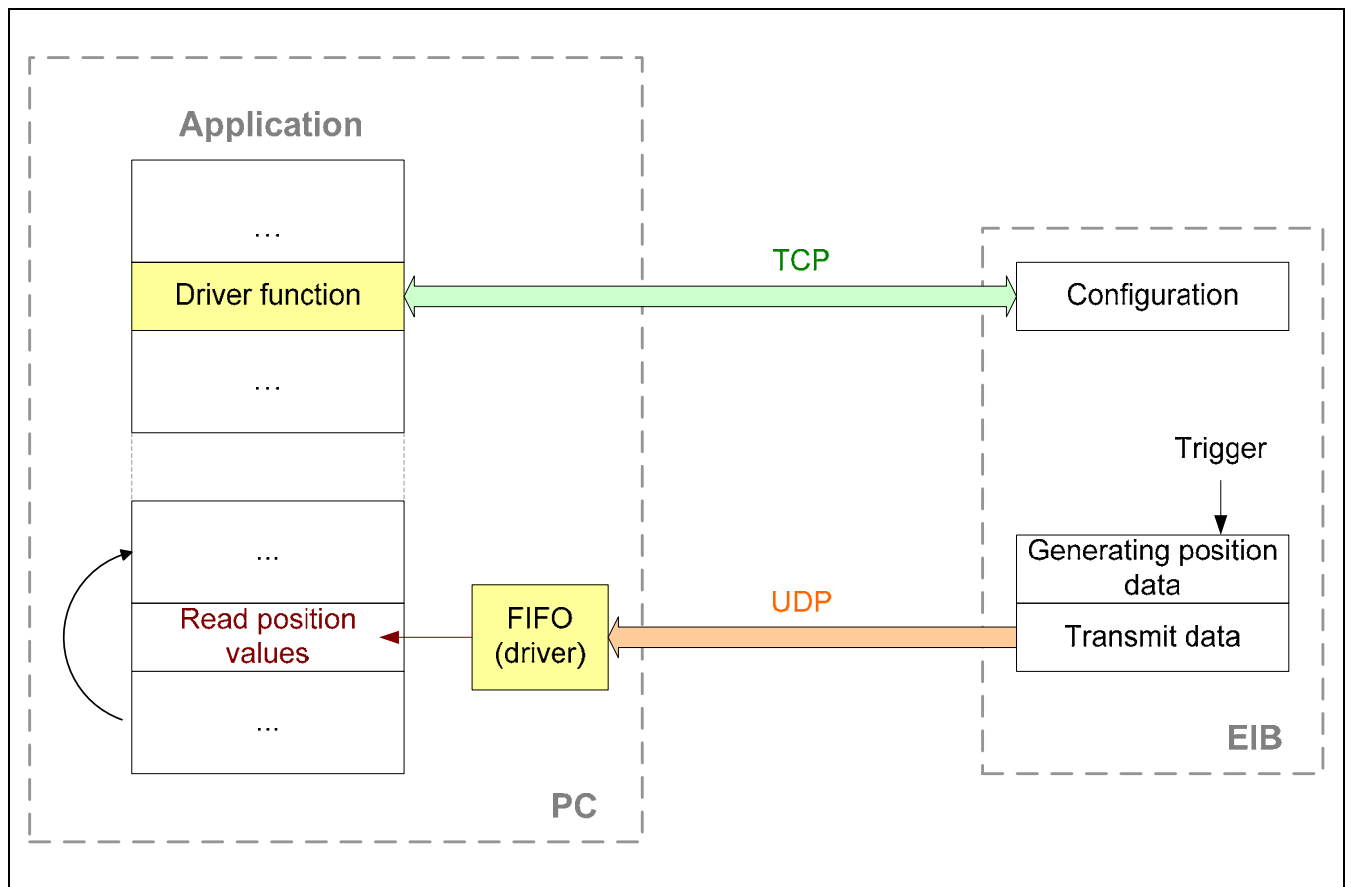

If the Ethernet connection is terminated in Soft Real-Time mode, e.g. by unplugging the Ethernet cable, the EIB 74x deactivates the trigger source and transmits no further UDP packets. Once the connection has been restored, the EIB 74x must be reconfigured for the operating mode.

When the application is closed, the above-mentioned initialization steps must be taken in the reverse order. The trigger source must be deactivated first. The operating mode can then be changed or the connection to the EIB 74x closed.

Processing trigger events:

- External trigger inputs are supported
- Internal trigger sources are supported
- Software triggers are supported

For correct interpretation of the data, the composition of the data packet must be considered during data evaluation.

7.4 "Streaming" Operating Mode

The position data are buffered by the EIB 74x and transported to the PC. This occurs parallel to the TCP communication via the standard Ethernet interface. The position data is generated when the EIB 74x receives a trigger signal. A data packet is generated with each trigger event. Depending on the trigger rate and data volume, multiple data packets are consolidated and transmitted to the PC. Here, the packets can be read from a FIFO.

For operation in Streaming mode, the EIB 74x must be configured following the steps listed below.

- Initialization of the EIB 74x
- Initialization and configuration of the axes
- Configuration of the data packet
- Configuration of the trigger logic
- Selection of the operating mode (Streaming)
- Activation of the trigger source

The diagram below illustrates the communication process schematically. The customer software application has to configure the EIB 74x. The data is then transmitted to the FIFO independently. From here, the application can read out the data within a program loop.

Parallel to the position poll, the status of the EIB 74x can be requested or error messages cleared. In particular, the status of the FIFO in the EIB 74x can be interrogated in order to detect overflow early.

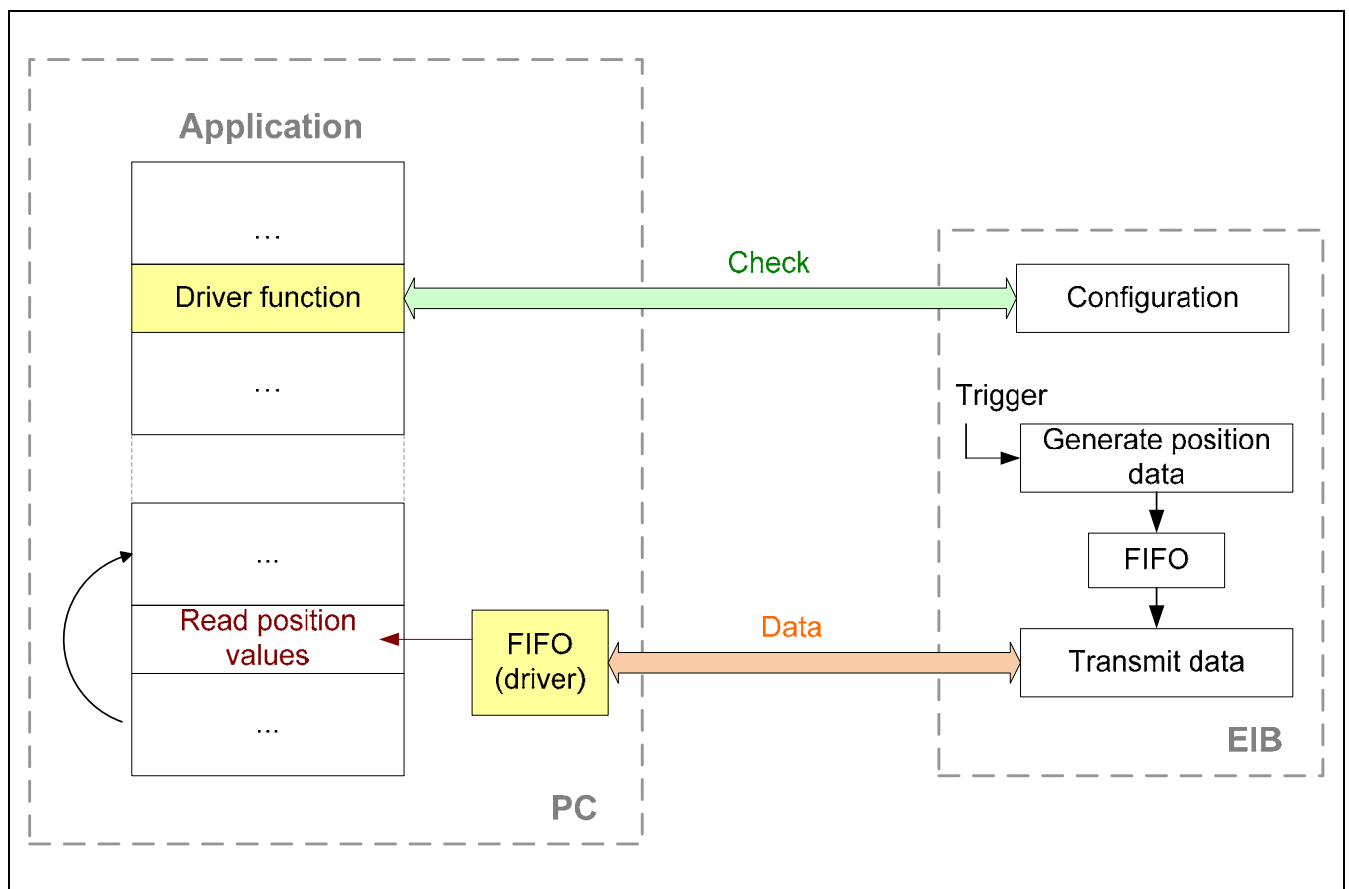

As soon as the position values from the FIFO are read on the PC, this is confirmed to the EIB. If further data are available in the EIB 74x, they are transmitted.

When the application is closed, the above-mentioned initialization steps must be taken in the reverse order. The trigger source must be deactivated first. The operating mode can then be changed or the connection to the EIB 74x closed.

Processing trigger events:

- External trigger inputs are supported
- Internal trigger sources are supported
- Software triggers are supported

For correct interpretation of the data, the composition of the data packet must be considered during data evaluation.

7.5 "Recording" Operating Mode

The position data is saved in the memory of the EIB 74x. A data packet is generated and saved with each trigger event. After the recording phase ends, the data can be transmitted.

The Recording operating mode supports two further modes. In Single Shot mode, data recording is automatically ended as soon as the memory is full. In the Rolling mode the data is saved in a ring buffer. When the memory is full, the oldest entry is overwritten. After the Recording mode is ended, the last n samples can be read from the memory.

The recording depth depends on the size of the data packet and can be read out (see Part 2, 7.42).

For operation in Recording mode, the EIB 74x must be configured following the steps listed below.

- Initialization of the EIB 74x
- Initialization and configuration of the axes
- Configuration of the data packet
- Configuration of the trigger logic
- Selection of the operating mode (Recording)
- Activation of the trigger source

After the recording phase is concluded, the following steps have to be taken:

- Deactivation of the trigger source
- Selection of the operating mode (Polling)
- Starting data transmission

The diagram below illustrates the communication process schematically. The customer software application has to configure the EIB 74x. In the first phase (recording) the data is saved in the EIB 74x. In the second phase (data transmission) the data is transmitted to the host and saved in a FIFO. From here, the application can read out the data within a program loop.

During the recording, the status of the EIB 74x can be requested or error messages cleared. In particular, the status of the memory in the EIB 74x can be interrogated.

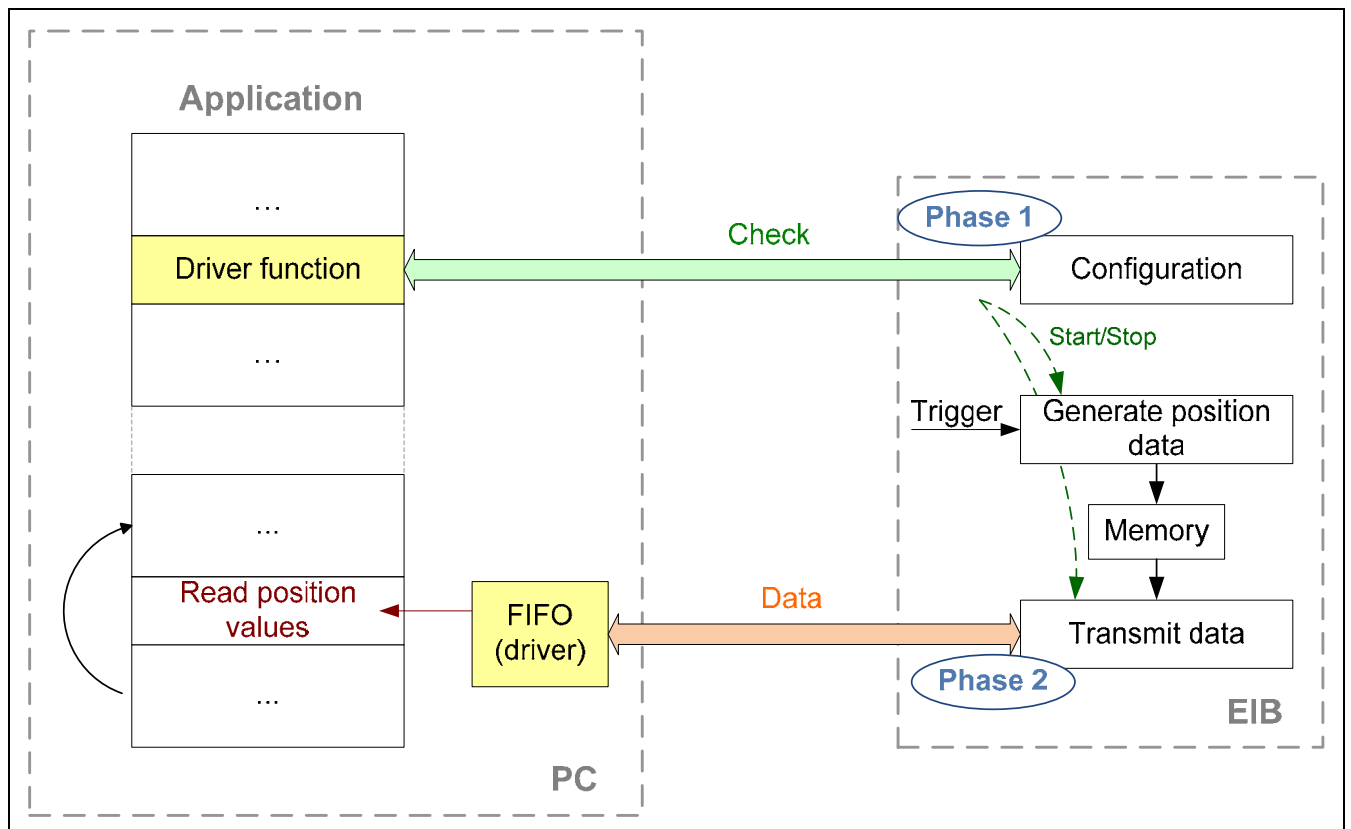

Processing trigger events:

- External trigger inputs are supported
- Internal trigger sources are supported
- Software triggers are supported

For correct interpretation of the data, the composition of the data packet must be considered during data evaluation.

8 Firmware Update

The EIB 74x firmware can be updated by the user with a TFTP client. However, only special update files from HEIDENHAIN may be installed on the EIB 74x.

The example below is based on a firmware update from a computer with "Windows" as its operating system. The EIB 74x must be connected to the computer via Ethernet. In this example, the file name for the update is "update_633281-10.flash". This file is saved under "C:\temp\EIB".

- Run the Windows command line
- Save the update file under "C:\temp\EIB\update_633281-10.flash"
- Start the TFTP file transfer:
> tftp -i 192.168.1.2 put C:\temp\EIB\update_633281-10.flash tmp\update.flash

Option -i:	Activates the "binary file transfer"
IP address:	"192.168.1.2" (default setting) or customer-specific setting
"Put" command:	Transfer from the host to the EIB 74x
Source file:	In this example "C:\temp\EIB\update_633281-10.flash"
Target file:	Always "tmp\update.flash"

If the file has been transferred successfully, the TFTP client displays a corresponding message in the command line. The status LED of the EIB 74x is switched off. After the internal data transmission to the flash memory, the status LED is switched back on. This process can take up to 60 seconds. While the status LED is off, the power supply must not be switched off and commands must not be sent to the EIB 74x via the Ethernet interface.

When the status LED is active again, the relevant software command is to be used to interrogate whether the update has been completed successfully. The status of the update process can be polled until the EIB 74x is booted again.

The EIB 74x boots the new version of the firmware after the next reset.

In case of an error during the firmware update, the corresponding settings shown in the "Resetting the EIB 74x" table (see "Commissioning Instructions") are booted.

9 Reset

See "Commissioning Instructions"

Part 2: Driver Software

1 General Information

Functions are provided for accessing the EIB 74x from a software application. This group of functions is supplied as DLL for Windows systems and as SO library for Linux. The following operating systems are supported:

- Windows 2000, Windows XP, Windows Vista, Windows 7
- Linux/Unix with kernel 2.6, (i386 systems)

In addition to the libraries, a header file that enables the functions to be integrated into C/C++ programs is also supplied. To create a program, the library must be incorporated into the project.

".vi" files are provided for LabView. They have the Windows DLL as their basis. The designation, functionality and input/output parameters of the ".vi" files orient themselves on the respective function calls, which are documented below. Particularly for complex data types it might be possible that the ".vi" file needs an adaptation specific to LabView, along with the DLL call. The corresponding adaptations are apparent when the ".vi" files are opened.

2 Installation Instructions

The stated directories and files refer to the driver CD for the EIB 74x.

2.1 Windows

For an application to load the DLL, file "eib7.dll" must be copied from the "EIB_74x\windows\bin" directory to the Windows system directory (e.g. "C:\Windows\system32"). For 64-bit operating systems, the file "eib7_64.dll" must be copied from "EIB_74x\windows\bin64" to the Windows system directory (e.g. "C:\Windows\system32") and renamed "eib7.dll". To ensure compatibility with 32-bit applications, the file "eib7.dll" should be copied to the system directory "SysWOW64" in the Windows folder (e.g. "C:\Windows"). Alternatively, the path for the DLL can be defined in the system. The DLL interface is defined via the two files "eib7.lib" in "EIB_74x\windows\lib" and "eib7.h" in "EIB_74x\windows\include". These must be incorporated into the software project in the development environment (for C/C++ environments). File "eib7.lib" must be copied into the library directory of the development environment or its path entered.

2.2 Linux

For an application to load the SO library, for 32-bit operating systems the file "libeib7.so" on the CD must be copied from the "EIB_74x/linux/lib" directory to the "usr/local/lib" directory. For 64-bit operating systems the file "libeib7_64.so" in the directory "EIB_74x/linux/lib64" must be used and renamed "libeib7.so". The library interface is defined via file "eib7.h" in "EIB_74x/linux/include". This must be copied to "usr/local/include" and must be incorporated into the software project in the development environment. The stated directories are based on the "Filesystem Hierarchy Standard" for Linux operating systems. The "libeib7.so" library was compiled for i386 systems under kernel 2.6.

3 Overview

3.1 Establishing Communication

To communicate with the EIB 74x, a connection must first be established using the EIB7Open() function. It is sometimes necessary to determine the IP address beforehand using EIB7GetHostIP(). The EIB 74x can then be configured using the device functions.

Access to the axes requires handles, which are generated by the EIB7GetAxis() function. This is also the case for the IO ports, whose handles are generated by the EIB7GetIO() function. The handles can be used for configuration and for polling the status.

At the end of communication, the connection must be closed using the EIB7Close() function.

3.2 Configuration of Data Packets

The data packet for the Soft Real-Time, Streaming and Recording operating modes must be configured before the modes are activated.

The configuration data are saved in an array of the EIB7_DataPacketSection type. One element of the array must be configured for each region. This can be done using the EIB7AddDataPacketSection() function (see 7.8). Then this configuration can be loaded into the EIB 74x using the EIB7ConfigDataPacket() function (see 7.9).

3.3 Polling Mode

The axis functions can be used to access the encoders. First, the axis must be configured via `EIB7InitAxis()`. The position values can then be read out or error messages acknowledged.

It is not necessary to select a trigger source. The triggering occurs implicitly when the `EIB7GetPosition()` function is called.

3.4 Soft Real-Time Mode

First the axes have to be initialized with `EIB7InitAxis()` and the data packet as well as the trigger logic must be configured. Then the Soft Real-Time mode can be activated. In Soft Real-Time mode, only the error messages from the status word for the position values can be reset.

After you have switched to Soft Real-Time mode, the trigger source can be activated. The customer software application on the host must continuously read the position data from the receive buffer to prevent an overflow. This can be done using the `EIB7ReadFIFOData()` or `EIB7ReadFIFODataRaw()` functions (see 7.44, 7.47). Each of these functions reads one or several entries from the FIFO. Each entry contains a data packet of the EIB 74x. The size of an entry can be determined in advance using the `EIB7SizeOfFIFOEntry()` and `EIB7SizeOfFIFOEntryRaw()` functions (see 7.45, 7.48). The individual components of a FIFO entry can be accessed using the `EIB7GetDataFieldPtr()` or `EIB7GetDataFieldPtrRaw()` function.

It is also possible to use the callback mechanism to register a function that is called as soon as new data is available in the FIFO (see 7.54).

3.5 Streaming Mode

First the axes have to be initialized with `EIB7InitAxis()` and the data packet as well as the trigger logic must be configured. Then the Streaming mode can be activated. In the Streaming mode, only the error messages from the status word for the position values can be reset, and the status of the buffer can be read out (see 7.43).

After you have switched to the Streaming mode, the trigger source can be activated. The customer software application on the host must continuously read the position data from the receive buffer to prevent an overflow. This can be done using the `EIB7ReadFIFOData()` or `EIB7ReadFIFODataRaw()` functions (see 7.44, 7.47). Each of these functions reads one or several entries from the FIFO. Each entry contains a data packet of the EIB 74x. The size of an entry can be determined in advance using the `EIB7SizeOfFIFOEntry()` and `EIB7SizeOfFIFOEntryRaw()` functions (see 7.45, 7.48). The individual components of a FIFO entry can be accessed using the `EIB7GetDataFieldPtr()` or `EIB7GetDataFieldPtrRaw()` function.

It is also possible to use the callback mechanism to register a function that is called as soon as new data is available in the FIFO (see 7.54).

3.6 Recording Mode

First the axes have to be initialized with `EIB7InitAxis()` and the data packet as well as the trigger logic must be configured. Once the Recording mode is active, the data is saved in the EIB 74x with each trigger event. The trigger source can be selected in the Recording mode. The status of the buffer memory is readable (see 7.41).

Once the recording is finished, the data can be transmitted to the host. This is done in Polling mode. The transmission is started with the `EIB7TransferRecordingData()` function. The customer's software application on the host can read out the position data from the receiving buffer using the `EIB7ReadFIFOData()` or `EIB7ReadFIFODataRaw()` function (see 7.44, 7.47). Each of these functions reads one or several entries from the FIFO. Each entry contains a data packet of the EIB 74x. The size of an entry can be determined in advance using the `EIB7SizeOfFIFOEntry()` and `EIB7SizeOfFIFOEntryRaw()` functions (see 7.45, 7.48). The individual components of a FIFO entry can be accessed using the `EIB7GetDataFieldPtr()` or `EIB7GetDataFieldPtrRaw()` function.

4 Data Types

4.1 Simple Data Types

EIB7_HANDLE	Handle for an EIB 74x
EIB7_AXIS	Handle for an axis on the EIB 74x
EIB7_IO	Handle for an input or output port on the EIB 74x
EIB7_ERR	Error message
ENCODER_POSITION	Position value (64-bit integer)

4.2 EnDat Additional Datum

```
struct ENDAT_ADDINFO
```

Component	Description
Status	Status word for the additional datum
info	Data of the additional datum

4.3 Information for TCP Connection

```
struct EIB7_CONN_INFO
```

Component	Description
id	Identification number for the connection
local_ip	Local IP address for this connection
local_port	Local port number for this connection
remote_ip	IP address of the EIB 74x for this connection
remote_port	Port number of the EIB 74x for this connection

4.4 Configuration for Data Packet

```
struct EIB7_DataPacketSection
```

Component	Description
region	Global information, or axis of the EIB 74x
items	Data elements within the region

5 Parameters and Return Codes

All functions supply a return code of the type EIB7_ERR. This labels a function call as successful or reports an error that occurred during execution.

Input values for the functions are transferred as variables (transfer by value). For return codes, a pointer to a variable is transferred; this variable contains the result after the function has been successfully executed (transfer by reference).

6 Auxiliary Functions

6.1 Determining the IP Address

The host name of the EIB 74x or the IP address (as C string) is converted to an IP address in "Host Byte Order." The name must be transferred as a C string. Examples are "192.168.1.2" or "EIB74x-SN1234567".

Function

```
EIB7_ERR EIB7GetHostIP      ( const char*      hostname,  
                             unsigned long*    ip  
                             )
```

Parameters

hostname	Pointer to a C string containing the IP address or the host name of the EIB 74x.
ip	<i>[return code]</i> Pointer to a variable to which the IP address of the EIB 74x is saved

Return code

The return code delivers a status for the function call. Possible values are listed below.

EIB7_NoError	Function call successful
EIB7_HostNotFound	IP address was unable to be determined

6.2 Changing the Position Data Format

The data format of a position value is converted from a 64-bit integer format to double format. The function can be used only for incremental encoders. The converted value has the unit "1 signal period." The period counter value corresponds to the part of the result before the decimal point; the decimal places are formed from the interpolation value.

Function

```
EIB7_ERR EIB7IncrPosToDouble ( ENCODER_POSITION  src,  
                               double*            dest  
                               )
```

Parameters

src	Position value of an incremental encoder
ip	<i>[return code]</i> Pointer to a variable to which the converted position is saved

Return code

The return code delivers a status for the function call. Possible values are listed below.

EIB7_NoError	Function call successful
EIB7_ParamInvalid	Transferred position value is invalid

7 Device Functions

The device functions always refer to the entire EIB 74x. No distinction between the axes is possible. With some functions, parameters of all axes are influenced.

All device functions are able to deliver the following error messages as a return code. They can also return further values individually. These are listed separately for each function.

Standard return codes

EIB7_NoError	Function call successful
EIB7_InvalidHandle	The handle to the EIB 74x is invalid
EIB7_FuncNotSupp	Function is not supported by the EIB 74x
EIB7_InvalidResponse	Error during data transmission
EIB7_AccNotAllowed	Function cannot be performed, as the EIB 74x does not permit access
EIB7_ConnReset	Connection terminated by the EIB 74x
EIB7_ConnTimeout	Timeout during data transmission to the EIB 74x
EIB7_ReceiveError	Error while receiving the data
EIB7_SendError	Error while sending the data
EIB7_OutOfMemory	The system is unable to allocate sufficient memory

7.1 Opening a Connection to the EIB 74x

A TCP connection is established with the EIB 74x. This does not result in any changes in the settings in the EIB 74x. If the connection cannot be established, an error message is returned. The driver must be compatible with the EIB 74x firmware to function correctly. This is verified once the connection is established. If necessary, the EIB 74x firmware version can be read using this function. To do this, the "ident" parameter must be used to transmit the address of a memory range to which the version number is written as a C string.

Function

```
EIB7_ERR EIB7Open          ( unsigned long    ip,  
                             EIB7_HANDLE*    eib,  
                             long            timeout,  
                             char*          ident,  
                             unsigned long   len  
                             )
```

Parameters

ip	IP address in "Host Byte Order"
eib	<i>[return code]</i> Handle for the EIB 74x if the function was closed successfully
timeout	Timeout for subsequent commands in milliseconds (not valid for EIB7Open())
ident	<i>[return code]</i> Pointer to the target memory in which the firmware version of the EIB 74x is saved as a C string. This memory must be at least 9 bytes large. If this parameter is a NULL pointer, the firmware version of the EIB 74x is not read.
len	Size of the target memory in bytes (0, where ident = NULL)

Return code

The return code delivers a status for the function call. In addition to the standard return codes, the following error messages can occur.

EIB7_CantInitWinSock	Socket layer of the operating system cannot be initialized (applies only for Windows)
EIB7_CantOpenSocket	System resources for connection not available
EIB7_OutOfMemory	Insufficient memory available
EIB7_IFVersionInv	EIB 74x firmware is incompatible with the driver
EIB7_CantConnect	Connection cannot be established (EIB 74x may have been switched off or is unavailable)

7.2 Closing the Connection to the EIB 74x

The connection to the EIB 74x is closed. The EIB Handle must not be used again. Likewise, all handles to axes generated from this EIB handle are invalid. If a special operating mode of the EIB 74x has been activated via this handle, Polling mode will be activated when the connection is closed. All other settings in the EIB 74x are retained.

Function

```
EIB7_ERR EIB7Close          ( EIB7_HANDLE      eib
                             )
```

Parameter

eib EIB handle

Return code

The return code delivers a status for the function call. All potential values are listed for the standard return codes.

7.3 Polling the Connection Status

The status of the connection to the EIB 74x is polled. This makes it possible to determine whether a connection has already been closed or a communication error has occurred. This function does not send data to the EIB 74x. The status refers to the previous commands.

Function

```
EIB7_ERR EIB7GetConnectionStatus ( EIB7_HANDLE      eib,
                                  EIB7_CONN_STATUS*      status
                                  )
```

Parameters

eib EIB handle
 status [*return code*] Pointer to the target variable for the status

Status	Description
EIB7_CS_Connected	Connection to the EIB 74x established
EIB7_CS_Closed	No connection to the EIB 74x
EIB7_CS_Timeout	Time exceeded during data transmission
EIB7_CS_ConnectionReset	The connection has been closed by the EIB 74x
EIB7_CS_TransmissionError	Transmission error occurred

Return code

The return code delivers a status for the function call. All potential values are listed for the standard return codes.

7.4 Setting Up Timeout

The timeout for the TCP connection to the EIB 74x is reset. This value applies for all subsequent function calls. The timeout must be at least 100 ms. Lower values are automatically increased to 100.

Function

```
EIB7_ERR EIB7SetTimeout     ( EIB7_HANDLE      eib,
                              long              timeout
                              )
```

Parameters

eib EIB handle
 timeout Timeout in milliseconds (>= 100)

Return code

The return code delivers a status for the function call. In addition to the standard return codes, the following error messages can occur.

EIB7_IllegalParameter The timeout cannot be set

7.5 Reading Out the Number of Axes

The number of axes with D-sub input in the EIB 74x is read out.

Function

```
EIB7_ERR EIB7GetNumOfAxes      ( EIB7_HANDLE      eib,  
                                unsigned long*    dsub,  
                                unsigned long*    res1,  
                                unsigned long*    res2,  
                                unsigned long*    res3  
                                )
```

Parameters

eib	EIB handle
dsub	<i>[return code]</i> Pointer to the target variable for the number of axes with D-sub input
res1	<i>[return code]</i> Reserved
res2	<i>[return code]</i> Reserved
res3	<i>[return code]</i> Reserved

Return code

The return code delivers a status for the function call. All potential values are listed for the standard return codes.

7.6 Requesting Handle for Axis

The handles for access to the axes of the EIB 74x are generated. They are saved in an array whose size must also be transferred as a parameter. The number of valid handles is delivered as a return code. For each axis of the EIB 74x, the function delivers one handle, the maximum being the number accommodated in the array ("size" parameter). The handles are stored in the array in ascending order, starting with axis 1.

Function

```
EIB7_ERR EIB7GetAxis          ( EIB7_HANDLE      eib,  
                                EIB7_AXIS*        set,  
                                unsigned long     size,  
                                unsigned long*    len  
                                )
```

Parameters

eib	EIB handle
set	<i>[return code]</i> Pointer to the first element of the handle array
size	Maximum number of entries in the array
len	<i>[return code]</i> Number of valid entries in the array

Return code

The return code delivers a status for the function call. All potential values are listed for the standard return codes.

7.7 Requesting IO Port Handle

Handles are generated for access to the IO ports of the EIB 74x. The handles for the inputs and the outputs are each saved in an array whose size must also be transferred as a parameter. The number of valid handles in the array is generated in "ilen" or "olen". For each IO port of the EIB 74x, the function delivers one handle, the maximum being the number accommodated in the array ("isize", "osize" parameters).

Function

```
EIB7_ERR EIB7GetIO           ( EIB7_HANDLE      eib,  
                                EIB7_IO*        iset,  
                                unsigned long   isize,  
                                unsigned long*  ilen,  
                                EIB7_IO*        oset,  
                                unsigned long   osize,  
                                unsigned long*  olen  
                                )
```

Parameters

eib	EIB handle
iset	<i>[return code]</i> Pointer to the first element of the array with the input handles
isize	Maximum number of entries in the "iset" array
ilen	<i>[return code]</i> Number of valid entries in the "iset" array
oset	<i>[return code]</i> Pointer to the first element of the array with the output handles
osize	Maximum number of entries in the "oset" array
olen	<i>[return code]</i> Number of valid entries in the "oset" array

Return code

The return code delivers a status for the function call. All potential values are listed for the standard return codes.

7.8 Creating a Data Packet

You can use this function to write the configuration for the data packet. One element from the array per function call is initialized for the configuration data. The index indicates the element, whereby the first element has the index 0. Each element consists of a region and the data elements. The region specifies the axis or the global information. Different data elements can be added for each region. All data elements for a region must be OR gated and transmitted as the "items" parameter. The data elements are specified as EIB7_DataPacketItem.

Function

```
EIB7_ERR EIB7AddDataPacketSection ( EIB_DataPacketSection* packet,
                                   unsigned long index,
                                   EIB7_DataRegion region,
                                   unsigned long items
                                   )
```

Parameters

packet Pointer to the array for the configuration data
 index Index of the array element
 region Region of the data packet

region	Description
EIB7_DR_Global	Global information
EIB7_DR_Encoder1	Data for axis 1
EIB7_DR_Encoder2	Data for axis 2
EIB7_DR_Encoder3	Data for axis 3
EIB7_DR_Encoder4	Data for axis 4
EIB7_DR_AUX	Data for auxiliary axis

items Data elements within the region (OR gate of more than one element possible)

items	Description
EIB7_PDF_TriggerCounter	Trigger counter (only in EIB7_DR_Global)
EIB7_PDF_StatusWord	Status word for position
EIB7_PDF_PositionData	Position value
EIB7_PDF_Timestamp	Timestamp for position
EIB7_PDF_Analog	ADC values for signals A and B
EIB7_PDF_ReferencePos	Reference position 1 and reference position 2
EIB7_PDF_DistCodedRef	Coded reference value
EIB7_PDF_EnDat_AI1	EnDat 2.2 additional datum 1
EIB7_PDF_EnDat_AI2	EnDat 2.2 additional datum 2

Return code

The return code delivers a status for the function call. In addition to the standard return codes, the following error messages can occur.

EIB7_ParamInvalid Parameter invalid

7.9 Configuring a Data Packet

The data packet for the Soft Real-Time, Streaming and Recording operating modes can be configured. The configuration is possible only in the Polling mode. The configuration is effective as soon as another operating mode is activated (except Polling).

Function

```
EIB7_ERR EIB7ConfigDataPacket ( EIB7_HANDLE eib,
                                 EIB_DataPacketSection* packet,
                                 unsigned long size
                                 )
```

Parameters

eib EIB handle
 packet Pointer to an array with the configuration data for the data packet
 size Maximum number of entries in the "packet" array

Return code

The return code delivers a status for the function call. In addition to the standard return codes, the following error messages can occur.

EIB7_ParamInvalid Parameter invalid
 EIB7_PacketTooLong The configuration data describe an excessively long data packet
 EIB7_InvalidPacket The configuration data describe an invalid data packet

7.10 Selecting the Operating Mode

The operating mode for the EIB 74x can be set. The Polling and Soft Real-Time, Streaming and Recording modes are supported. In the Recording operating mode you can choose between "single shot" and "rolling" operation.

Function

```
EIB7_ERR EIB7SelectMode      ( EIB7_HANDLE      eib,
                               EIB7_OPERATING_MODE    mode
                               )
```

Parameters

eib EIB handle
mode Operating mode

mode	Operating mode
EIB7_OM_Polling	Polling mode
EIB7_OM_SoftRealtime	Soft Real-Time mode
EIB7_OM_Streaming	Streaming mode
EIB7_OM_RecordingSingle	Recording mode, single shot
EIB7_OM_RecordingRoll	Recording mode, rolling

Return code

The return code delivers a status for the function call. In addition to the standard return codes, the following error messages can occur.

EIB7_CantOpenSocket Internal error (socket error)
EIB7_CantStartThread Internal error (thread error)
EIB7_InvalidOpMode The selected operating mode is not supported.
EIB7_OpModeActive The selected operating mode is already active
EIB7_OpModeBlocked The selected operating mode cannot be activated.
EIB7_InvalidIPAddr Internal error (IP address error)

7.11 Saving Network Parameters

The parameters for the Ethernet interface of the EIB 74x can be set. This means the EIB 74x can be adapted to the network. The settings do not take effect until after the next boot process. If the DHCP client is active, the EIB 74x tries to obtain an IP address from the DHCP server. If the server fails to respond within the set timeout, the configured IP address will be used.

Function

```
EIB7_ERR EIB7SetNetwork     ( EIB7_HANDLE      eib,
                               unsigned long    ip,
                               unsigned long    netmask,
                               unsigned long    gateway,
                               EIB7_MODE      dhcp,
                               unsigned long    timeout
                               )
```

Parameters

eib EIB handle
ip IP address of the EIB 74x in "Host Byte Order"
netmask Network mask for the network in "Host Byte Order"
gateway IP address of the standard gateway in "Host Byte Order"
dhcp Flag for the DHCP client in the EIB 74x

dhcp	Description
EIB7_MD_Disable	Deactivate DHCP client
EIB7_MD_Enable	Activate DHCP client

timeout Timeout for the DHCP client in seconds

Return code

The return code delivers a status for the function call. In addition to the standard return codes, the following error messages can occur.

EIB7_CantSaveCustNW Network settings cannot be saved
EIB7_CantSaveDHCP DHCP timeout cannot be saved
EIB7_DHCPTimeoutInv DHCP timeout invalid
EIB7_ParamInvalid Parameters are not a valid network configuration

7.12 Reading out the Network Parameters

The parameters for the Ethernet interface can be read. The user-defined settings are always displayed, even if standard settings are used for booting.

Function

```
EIB7_ERR EIB7GetNetwork      ( EIB7_HANDLE      eib,
                               unsigned long*    ip,
                               unsigned long*    netmask,
                               unsigned long*    gateway,
                               EIB7_MODE*       dhcp
                               )
```

Parameters

eib	EIB handle
ip	<i>[return code]</i> Pointer to the variable for the IP address in "Host Byte Order"
netmask	<i>[return code]</i> Pointer to the variable for the network mask in "Host Byte Order"
gateway	<i>[return code]</i> Pointer to the variable for the IP address of the standard gateway in "Host Byte Order"
dhcp	<i>[return code]</i> Pointer to the variable for the flag for the DHCP client

dhcp	Description
EIB7_MD_Disable	DHCP client inactive
EIB7_MD_Enable	DHCP client active

Return code

The return code delivers a status for the function call. In addition to the standard return codes, the following error messages can occur.

EIB7_NoCustNetwork No customized settings present

7.13 Saving the Host Name

The host name of the EIB 74x is saved. The name must be transmitted as a C string, which can be a maximum of 32 characters long including the null byte. If it is any longer, the rest will be cut off. If a string with a length of zero or a NULL pointer is transferred, the EIB 74x sets the host name to the factory default setting.

Function

```
EIB7_ERR EIB7SetHostname    ( EIB7_HANDLE      eib,
                               const char*       hostname
                               )
```

Parameters

eib	EIB handle
hostname	Pointer to the new host name

Return code

The return code delivers a status for the function call. In addition to the standard return codes, the following error messages can occur.

EIB7_HostnameTooLong	Host name is too long
EIB7_HostnameInvalid	Host name is invalid
EIB7_CantSaveHostn	Host name cannot be saved
EIB7_CantRestDefHn	Standard host name cannot be loaded

7.14 Reading out the Host Name

The host name of the EIB 74x is read and saved in the target memory as a C string. The string is up to 32 characters long (incl. the null byte). If the target memory is not big enough to take the entire string, only the first part is copied.

Function

```
EIB7_ERR EIB7GetHostname      ( EIB7_HANDLE      eib,  
                                char*                    hostname,  
                                unsigned long             len  
                                )
```

Parameters

eib	EIB handle
hostname	<i>[return code]</i> Pointer to the target memory for the host name
len	Size of the target memory in bytes

Return code

The return code delivers a status for the function call. In addition to the standard return codes, the following error messages can occur.

EIB7_CantRdHostname	Host name cannot be read
---------------------	--------------------------

7.15 Reading out the Serial Number

The serial number of the EIB 74x is displayed as a C string. The string is written to the target memory. If the target string does not provide sufficient space for the serial number, an error will be generated. The serial number can be up to 24 characters long (incl. the null byte).

Function

```
EIB7_ERR EIB7GetSerialNumber  ( EIB7_HANDLE      eib,  
                                char*                    serial,  
                                unsigned long             len  
                                )
```

Parameters

eib	EIB handle
serial	<i>[return code]</i> Pointer to the target memory for the serial number
len	Size of the target memory in bytes

Return code

The return code delivers a status for the function call. In addition to the standard return codes, the following error messages can occur.

EIB7_CantRdSer	Serial number cannot be read
EIB7_BufferTooSmall	Target memory is too small

7.16 Reading out the Device ID

The device ID of the EIB 74x is generated as a C string. The string is written to the target memory. If the target string does not provide sufficient space for the number, an error will be generated. The number can be up to 16 characters long (incl. the null byte).

Function

```
EIB7_ERR EIB7GetIdentNumber   ( EIB7_HANDLE      eib,  
                                char*                    ident,  
                                unsigned long             len  
                                )
```

Parameters

eib	EIB handle
ident	<i>[return code]</i> Pointer to the target memory for the device number
len	Size of the target memory in bytes

Return code

The return code delivers a status for the function call. In addition to the standard return codes, the following error messages can occur.

EIB7_CantRdldent	Device number cannot be read
EIB7_BufferTooSmall	Target memory is too small

7.17 Reading out the MAC Address

The MAC address of the EIB 74x is displayed. The address is output in binary format. The target memory must be at least 6 bytes. The first six bytes are always used. The lowest-value byte of the MAC address is copied to the first byte of the target memory. For example for "00:A0:CD:85:00:01".

Offset	Memory contents
0	0x01
1	0x00
2	0x85
3	0xCD
4	0xA0
5	0x00

Function

```
EIB7_ERR EIB7GetMAC ( EIB7_HANDLE eib,
                      unsigned char* mac
                    )
```

Parameters

eib EIB handle
 mac *[return code]* Pointer to the target memory for the MAC address

Return code

The return code delivers a status for the function call. All potential values are listed for the standard return codes.

7.18 Reading out the Firmware Version Number

The version number of the EIB 74x firmware is read. The "select" parameter determines the firmware from which the version number is output as a C string. For the string, including the null byte, the target memory must be at least 9 bytes. If the target memory is too small to take the entire string, only the first part is copied.

Function

```
EIB7_ERR EIB7GetVersion ( EIB7_HANDLE eib,
                          char* ident,
                          unsigned long len,
                          EIB7_FIRMWARE select
                        )
```

Parameters

eib EIB handle
 ident *[return code]* Pointer to the target memory for the firmware version number
 len Size of the target memory in bytes
 select Selects the firmware whose version number is read

select	Description
EIB7_FW_CurrentlyBooted	Firmware currently loaded
EIB7_FW_Factory	Firmware of factory default settings
EIB7_FW_User	Firmware of the last update

Return code

The return code delivers a status for the function call. All potential values are listed for the standard return codes.

7.19 Reading out the Boot Mode

The boot mode in which the EIB 74x was started during the last boot process is read out.

Function

```
EIB7_ERR EIB7GetBootMode      ( EIB7_HANDLE      eib,
                               EIB7_BOOT_MODE*    mode
                               )
```

Parameters

eib EIB handle
 status *[return code]* Pointer to the variable for boot mode

mode	Description
EIB7_BM_User	Firmware of the last update with user's network settings
EIB7_BM_FactoryUser	Firmware of factory default settings with user's network settings
EIB7_BM_FactoryDefault	Firmware of factory default settings with standard network settings

Return code

The return code delivers a status for the function call. All potential values are listed for the standard return codes.

7.20 Reading out the Update Status

The status can be read to verify whether an update was completed successfully. The function call automatically resets the status to the default status (EIB7_US_NoUpdate) after the read operation. The status information is cleared during each boot process.

Function

```
EIB7_ERR EIB7UpdateState      ( EIB7_HANDLE      eib,
                               EIB7_UPDATE_STATUS*    status
                               )
```

Parameters

eib EIB handle
 status *[return code]* Pointer to the variable for the update status

Status	Description
EIB7_US_NoUpdate	No update loaded
EIB7_US_UpdateFailed	Update unable to be performed
EIB7_US_UpdateSuccessful	Update performed successfully
EIB7_US_VersionIncompatible	Firmware is incompatible with the EIB 74x hardware

Return code

The return code delivers a status for the function call. All potential values are listed for the standard return codes.

7.21 Reading the Number of Open Connections

The number of currently open connections to the EIB 74x is generated. This also includes semi-open connections that the remote station has already closed but are still open on the EIB 74x.

Function

```
EIB7_ERR EIB7GetNumberOfOpenConnections      ( EIB7_HANDLE      eib,
                                               unsigned long*    cnt
                                               )
```

Parameters

eib EIB handle
 cnt *[return code]* Pointer to the variable for the number of open connections

Return code

The return code delivers a status for the function call. All potential values are listed for the standard return codes.

7.22 Reading out the Connection Data

The connection data of all currently open connections to the EIB 74x can be read. For each connection, an array entry is used. However, the maximum is the number specified by the "size" parameter. The number of valid elements in the array is returned by the "cnt" parameter. The contents of the connection data are listed in the "Data types" section.

Function

```
EIB7_ERR EIB7ConnectionInfo ( EIB7_HANDLE      eib,  
                              EIB7_CONN_INFO*   info,  
                              unsigned long     size,  
                              unsigned long*    cnt  
                              )
```

Parameters

eib	EIB handle
info	<i>[return code]</i> Pointer to the first element in the array for the connection data
size	Size of the "info" array
cnt	<i>[return code]</i> Pointer to the variable for the number of valid elements in the array

Return code

The return code delivers a status for the function call. All potential values are listed for the standard return codes.

7.23 Terminating the Connection

An open connection to the EIB 74x can be terminated. It is not possible to close the connection used to call the function. The primary use of this function is to close semi-open connections that have not been terminated properly due, for example, to an error on the host. The ID can be taken from connection data EIB7_CONN_INFO (see "Read connection data").

Function

```
EIB7_ERR EIB7TerminateConnection ( EIB7_HANDLE      eib,  
                                   unsigned long     id  
                                   )
```

Parameters

eib	EIB handle
id	ID of the terminated connection

Return code

The return code delivers a status for the function call. In addition to the standard return codes, the following error messages can occur.

EIB7_CantTermConn	The connection cannot be terminated
EIB7_CantTermSelf	The connection cannot terminate itself
EIB7_ParamInvalid	The parameter is not a valid index for a connection

7.24 Reading the Time Unit Timestamp

The timestamp counter is supplied from a clock-pulse source. The timestamp ticks indicate how many clock pulses per microsecond are generated from the clock-pulse source.

Function

```
EIB7_ERR EIB7GetTimestampTicks ( EIB7_HANDLE      eib,  
                                 unsigned long*    ticks  
                                 )
```

Parameters

eib	EIB handle
ticks	<i>[return code]</i> Pointer to the variable for the number of clock pulses per microsecond

Return code

The return code delivers a status for the function call. All potential values are listed for the standard return codes.

7.25 Setting the Timestamp Period Duration

The period duration of the freely running timestamp counter can be set. To do this, the length of the timestamp period must be indicated in timestamp ticks. This value must be a natural number greater than zero.

Function

```
EIB7_ERR EIB7SetTimestampPeriod ( EIB7_HANDLE eib,
                                unsigned long  period
                                )
```

Parameters

eib EIB handle
period Ticks per timestamp period (> 0); also see "Note" in Chapter 4

Return code

The return code delivers a status for the function call. In addition to the standard return codes, the following error messages can occur.

EIB7_ParamInvalid Timestamp period invalid

7.26 Resetting the Timestamp Counter

The timestamp counter is set to zero and continues counting from this value.

Function

```
EIB7_ERR EIB7ResetTimestamp ( EIB7_HANDLE eib
                               )
```

Parameter

eib EIB handle

Return code

The return code delivers a status for the function call. All potential values are listed for the standard return codes.

7.27 Reading the Timer-Trigger Time Unit

The timer trigger is supplied from a clock-pulse source. The timer-trigger ticks indicate how many clock pulses per microsecond are generated by the clock-pulse source.

Function

```
EIB7_ERR EIB7GetTimerTriggerTicks ( EIB7_HANDLE eib,
                                     unsigned long* ticks
                                     )
```

Parameters

eib EIB handle
ticks *[return code]* Pointer to the variable for the number of clock pulses per microsecond

Return code

The return code delivers a status for the function call. All potential values are listed for the standard return codes.

7.28 Setting the Timer Trigger Period Duration

The period duration of the timer trigger can be set. To do this, the number of timer-trigger ticks making up a period must be stated. This value must be a natural number greater than zero. If the timer trigger is activated, it will initiate a trigger event after each period.

Function

```
EIB7_ERR EIB7SetTimerTriggerPeriod ( EIB7_HANDLE eib,
                                       unsigned long  period
                                       )
```

Parameters

eib EIB handle
period Ticks per timer trigger period (> 0); also see "Note" in Chapter 4

Return code

The return code delivers a status for the function call. In addition to the standard return codes, the following error messages can occur.

EIB7_ParamInvalid Trigger period invalid

7.29 Reading the Time Unit for the Delay Time at the Trigger Inputs

The trigger input delay ticks indicate how many clock pulses per microsecond are generated by the clock-pulse source for the delay time of the signals at the trigger input. The delay time of the trigger signals can be set to a multiple of the internal clock-pulse period.

Function

```
EIB7_ERR EIB7GetTriggerDelayTicks ( EIB7_HANDLE eib,
                                   unsigned long* ticks
                                   )
```

Parameters

eib EIB handle
ticks *[return code]* Pointer to target variable for clock pulses per microsecond

Return code

The return code delivers a status for the function call. All potential values are listed for the standard return codes.

7.30 Clearing the Trigger Counter

The trigger counter is set to zero.

Function

```
EIB7_ERR EIB7ResetTriggerCounter ( EIB7_HANDLE eib
                                   )
```

Parameter

eib EIB handle

Return code

The return code delivers a status for the function call. All potential values are listed for the standard return codes.

7.31 Software Trigger

The software trigger generates a trigger event and induces the EIB 74x to send data to the remote station. The "source" parameter is used to select one of the software trigger channels. This function cannot be performed in Polling mode.

Function

```
EIB7_ERR EIB7SoftwareTrigger ( EIB7_HANDLE eib,
                                unsigned long source
                                )
```

Parameters

eib EIB handle
source Software trigger channel

source	Description
EIB7_ST_SWtrigger1	Software trigger channel 1
EIB7_ST_SWtrigger2	Software trigger channel 2
EIB7_ST_SWtrigger3	Software trigger channel 3
EIB7_ST_SWtrigger4	Software trigger channel 4

Return code

The return code delivers a status for the function call. In addition to the standard return codes, the following error message can occur.

EIB7_ParamInvalid Parameter invalid

7.32 Selecting the Master Trigger Source

The master trigger signal can be selected from different sources. This function must be performed for the axes after configuring the trigger matrix and is permitted only in the Polling mode.

Function

```
EIB7_ERR EIB7MasterTriggerSource ( EIB7_HANDLE eib,  
                                   EIB7_AxisTriggerSrc src  
                                   )
```

Parameters

eib EIB handle
src Trigger source

src	Description
EIB7_AT_TrgInput1	Trigger input channel 1
EIB7_AT_TrgInput2	Trigger input channel 2
EIB7_AT_TrgInput3	Trigger input channel 3
EIB7_AT_TrgInput4	Trigger input channel 4
EIB7_AT_TrgSW1	Software trigger channel 1
EIB7_AT_TrgSW2	Software trigger channel 2
EIB7_AT_TrgSW3	Software trigger channel 3
EIB7_AT_TrgSW4	Software trigger channel 4
EIB7_AT_TrgRI	Reference pulse of the corresponding axis
EIB7_AT_TrgRImaskedCH1	Gated reference pulse of axis 1 (A&B&RI)
EIB7_AT_TrgIC	Interval counter
EIB7_AT_TrgPuls	Pulse-counter trigger
EIB7_AT_TrgTimer	Timer trigger

Return code

The return code delivers a status for the function call. In addition to the standard return codes, the following error messages can occur.

EIB7_ParamInvalid Parameter invalid

7.33 Activating Trigger Sources

The trigger sources of the EIB 74x can be activated/deactivated individually or collectively. The "src" parameter enables you to select multiple trigger sources by gating the corresponding constants with an OR gate. The period duration for the timer trigger must be configured before activation. If multiple trigger sources are activated by one function call, they are activated simultaneously.

Function

```
EIB7_ERR EIB7GlobalTriggerEnable ( EIB7_HANDLE eib,
                                   EIB7_MODE mode,
                                   unsigned long src
                                   )
```

Parameters

eib EIB handle
mode Activate or deactivate trigger sources

mode	Description
EIB7_MD_Enable	Activate trigger source
EIB7_MD_Disable	Deactivate trigger source

src Trigger source

src	Description
EIB7_TS_TrgInput1	Trigger input channel 1
EIB7_TS_TrgInput2	Trigger input channel 2
EIB7_TS_TrgInput3	Trigger input channel 3
EIB7_TS_TrgInput4	Trigger input channel 4
EIB7_TS_TrgRI1	Reference pulse of axis 1
EIB7_TS_TrgRI2	Reference pulse of axis 2
EIB7_TS_TrgRI3	Reference pulse of axis 3
EIB7_TS_TrgRI4	Reference pulse of axis 4
EIB7_TS_TrgRImaskedCH1	Gated reference pulse of axis 1 (A&B&RI)
EIB7_TS_TrgIC	Interval counter
EIB7_TS_TrgPuls	Pulse-counter trigger
EIB7_TS_TrgTimer	Timer trigger
EIB7_TS_All	All trigger sources

Return code

The return code delivers a status for the function call. In addition to the standard return codes, the following error messages can occur.

EIB7_ParamInvalid Parameter invalid

7.34 Configuring the Pulse Counter

A trigger signal and a start signal can be selected for the pulse counter. The start signal enables the pulse counter. The counter will then be decremented with each pulse at the trigger signal until a value of zero is reached. Then all further trigger pulses will be disabled. If the function is re-run before the counter has reached zero, the counter will be reset to the initial value.

Function

```
EIB7_ERR EIB7ConfigPulsCounter ( EIB7_HANDLE eib,
                                EIB7_PulsCounterStart start,
                                EIB7_PulsCounterTrigger trigger,
                                unsigned long count
                                )
```

Parameters

eib EIB handle
start Start signal for pulse counter

start	Description
EIB7_PS_TrgInput1	Trigger input channel 1
EIB7_PS_TrgInput2	Trigger input channel 2
EIB7_PS_TrgInput3	Trigger input channel 3
EIB7_PS_TrgInput4	Trigger input channel 4
EIB7_PS_TrgRI1	Reference pulse of axis 1
EIB7_PS_TrgRI2	Reference pulse of axis 2
EIB7_PS_TrgRI3	Reference pulse of axis 3
EIB7_PS_TrgRI4	Reference pulse of axis 4
EIB7_PS_TrgSW1	Software trigger channel 1
EIB7_PS_TrgSW2	Software trigger channel 2
EIB7_PS_TrgSW3	Software trigger channel 3
EIB7_PS_TrgSW4	Software trigger channel 4
EIB7_PS_TrgRImaskedCH1	Gated reference pulse of axis 1 (A&B&RI)
EIB7_PS_TrgIC	Interval counter

trigger Trigger signal for pulse counter

trigger	Description
EIB7_PT_TrgInput1	Trigger input channel 1
EIB7_PT_TrgInput2	Trigger input channel 2
EIB7_PT_TrgInput3	Trigger input channel 3
EIB7_PT_TrgInput4	Trigger input channel 4
EIB7_PT_TrgRI1	Reference pulse of axis 1
EIB7_PT_TrgRI2	Reference pulse of axis 2
EIB7_PT_TrgRI3	Reference pulse of axis 3
EIB7_PT_TrgRI4	Reference pulse of axis 4
EIB7_PT_TrgRImaskedCH1	Gated reference pulse of axis 1 (A&B&RI)
EIB7_PT_TrgIC	Interval counter
EIB7_PT_TrgTimer	Timer trigger

count Start value for pulse counter (0x00000 to 0xFFFFF)

Return code

The return code delivers a status for the function call. In addition to the standard return codes, the following error messages can occur.

EIB7_ParamInvalid Parameter invalid

7.35 Setting the Interpolation Factor for the Interval Counter

The interpolation factor for the interval counter is adjustable and determines the number of counting steps per signal period. This setting has an effect on both the interval counter and the auxiliary axis. The number of counting steps per signal period of the connected encoder is determined from the interpolation factor multiplied by the edge evaluation.

Function

```
EIB7_ERR EIB7SetIntervalCounterInterpolation ( EIB7_HANDLE          eib,
                                              EIB7_IntervalCounterIPF ipf,
                                              EIB7_IntervalCounterEdge edge
                                              )
```

Parameters

eib EIB handle
 ipf Interpolation factor

ipf	Description
EIB7_ICF_1x	1-fold interpolation
EIB7_ICF_2x	2-fold interpolation
EIB7_ICF_4x	4-fold interpolation
EIB7_ICF_5x	5-fold interpolation
EIB7_ICF_10x	10-fold interpolation
EIB7_ICF_20x	20-fold interpolation
EIB7_ICF_25x	25-fold interpolation
EIB7_ICF_50x	50-fold interpolation
EIB7_ICF_100x	100-fold interpolation

edge Edge evaluation

ipf	Description
EIB7_ICE_1x	1-fold edge evaluation
EIB7_ICE_2x	2-fold edge evaluation
EIB7_ICE_4x	4-fold edge evaluation

Return code

The return code delivers a status for the function call. In addition to the standard return codes, the following error messages can occur.

EIB7_ParamInvalid Parameter invalid

7.36 Configuring the Interval Counter

This function is used to configure interval-counter triggering. The interval counter provides two modes. In the first mode, a trigger pulse is generated only at a fixed position. This position is adjustable. The second mode permits triggering at fixed intervals. The first trigger pulse is generated at the start position. Then a trigger pulse is generated at fixed intervals that can be adjusted using the "interval" parameter. As an alternative, the current position can also be used as start position.

Function

```
EIB7_ERR EIB7SetIntervalCounterTrigger ( EIB7_HANDLE          eib,
                                         EIB7_IntervalCounterMode mode,
                                         EIB7_IntervalCounterStart start,
                                         unsigned long          startpos,
                                         unsigned long          interval
                                         )
```

Parameters

eib EIB handle
mode Trigger mode

mode	Description
EIB7_ICM_Disable	No triggering
EIB7_ICM_Single	Triggering only at a fixed position
EIB7_ICM_Periodic	Periodic triggering at fixed intervals

start Start of triggering

start	Description
EIB7_ICS_Current	Triggering starts at the current position
EIB7_ICS_StartPos	Triggering starts at the start position

startpos Position value for the first trigger pulse
interval Interval between two trigger pulses in counting steps (≥ 6)

Return code

The return code delivers a status for the function call. In addition to the standard return codes, the following error messages can occur.

EIB7_ParamInvalid Parameter invalid

7.37 Setting the Terminating Resistors

The terminating resistors for the incremental signals of the encoder inputs can be deactivated. This setting always applies for all 1 V_{PP} inputs on the EIB 74x. The resistors are activated after every boot process of the EIB 74x.

Function

```
EIB7_ERR EIB7EnableIncrementalTermination ( EIB7_HANDLE          eib,
                                             EIB7_MODE            mode
                                             )
```

Parameters

eib EIB handle
mode Activate or deactivate terminating resistors

mode	Description
EIB7_MD_Disable	Deactivate terminating resistors
EIB7_MD_Enable	Activate terminating resistors

Return code

The return code delivers a status for the function call. In addition to the standard return codes, the following error messages can occur.

EIB7_CantChInclnTrm Mode cannot be changed

7.38 Reset

The EIB 74x performs a reset and reboots. This function has the same effect as pressing the reset button. The standard boot mode is used (firmware of the last update with user's network settings). The connection to the EIB 74x is automatically closed (as with EIB7Close).

Function

```
EIB7_ERR EIB7Reset          ( EIB7_HANDLE      eib
                             )
```

Parameter

eib EIB handle

Return code

The return code delivers a status for the function call. All potential values are listed for the standard return codes.

7.39 Identifying the EIB 74x

The LAN LED on the front panel of the EIB 74x can be set to flash mode. If several devices are arranged side by side, an EIB 74x with a certain IP address is easily located. The LED flashes until the mode is terminated using the function.

Function

```
EIB7_ERR EIB7Identify      ( EIB7_HANDLE      eib,
                             EIB7_MODE        mode
                             )
```

Parameters

eib EIB handle
mode Activate or deactivate LED flashing

mode	Description
EIB7_MD_Disable	Deactivate flash mode
EIB7_MD_Enable	Activate flash mode

Return code

The return code delivers a status for the function call. In addition to the standard return codes, the following error messages can occur.

EIB7_IllegalParameter LED status cannot be changed (parameter is invalid)

7.40 Transferring the Recording Data

The transmission of data from the EIB 74x's internal recording buffer can be activated or deactivated. When the data transmission is activated, it is possible to select only one range of the recorded data for transmission. The first byte to be transmitted is given through the offset and the length specifies the number of bytes.

To transmit all the data, the parameter offset should be = 0 and length should be = 0xFFFFFFFF.

Function

```
EIB7_ERR EIB7TransferRecordingData ( EIB7_HANDLE eib,
                                     EIB7_MODE mode,
                                     unsigned long offset,
                                     unsigned long length
                                     )
```

Parameters

eib EIB handle
mode Activate or deactivate the data transmission

mode	Description
EIB7_MD_Disable	Stop data transmission
EIB7_MD_Enable	Start data transmission

offset Offset for the first byte to be transmitted
length Number of bytes to be transmitted (0xFFFFFFFF = to the end of the recording)

Return code

The return code delivers a status for the function call. In addition to the standard return codes, the following error messages can occur.

EIB7_CantOpenSocket Internal error (socket error)
EIB7_CantStartThread Internal error (thread error)
EIB7_OpModeBlocked The EIB 74x is not in the Polling mode.
EIB7_RecDataReadErr Data cannot be read from the EIB 74x.
EIB7_ParamInvalid Parameter invalid

7.41 Verifying the Recording Status

The status in the Recording mode can be read out. In addition, the current content in the buffer memory can be determined. This is also possible during recording in the Recording mode. The progress of data transmission from out of the EIB 74x's buffer to the host can also be read out.

Function

```
EIB7_ERR EIB7GetRecordingStatus ( EIB7_HANDLE eib,
                                   unsigned long* length,
                                   unsigned long* status,
                                   unsigned long* progress
                                   )
```

Parameters

eib EIB handle
length *[return code]* Pointer to the target variable for the number of data packets in the buffer
status *[return code]* Pointer to the target variable for the status

Status	Description
0	Recording mode deactivated
1	Recording mode activated
2	Data is being transmitted
3	Waiting for connection setup for data transmission

progress *[return code]* Pointer to the target variable for the progress of data transmission
Progress in percent (0 to 100)

Return code

The return code delivers a status for the function call. All potential values are listed for the standard return codes.

7.42 Reading the Recording Memory Size

The size of the memory for the recorded data in the EIB 74x can be read out. The size is provided as the number of data packets that can be accommodated by the memory. This number depends on the size of a data packet. The data packet must therefore be configured first.

Function

```
EIB7_ERR EIB7GetRecordingMemSize ( EIB7_HANDLE eib,
                                  unsigned long* size
                                )
```

Parameters

eib	EIB handle
size	<i>[return code]</i> Pointer to the target variable for the size of the memory (as a number of data packets)

Return code

The return code delivers a status for the function call. In addition to the standard return codes, the following error messages can occur.

EIB7_InvalidPacket	Current configuration for the data packet is invalid
--------------------	--

7.43 Checking the Streaming Status

While the Streaming mode is active, the status of the buffer in the EIB 74x can be read out. In addition to the size of the buffer in bytes, the quantity of currently saved data is indicated in bytes. Also, the maximum quantity of data in the buffer since activation of the Streaming mode is indicated in bytes.

Function

```
EIB7_ERR EIB7GetStreamingStatus ( EIB7_HANDLE eib,
                                   unsigned long* length,
                                   unsigned long* max,
                                   unsigned long* size
                                 )
```

Parameters

eib	EIB handle
length	<i>[return code]</i> Pointer to the target variable for the number of bytes in the buffer
max	<i>[return code]</i> Pointer to the target variable for the maximum number of bytes in the buffer since the start of the Streaming mode
size	<i>[return code]</i> Pointer to the target variable for the size of the buffer in bytes

Return code

The return code delivers a status for the function call. All potential values are listed for the standard return codes.

7.44 Reading Data from the FIFO

Data packets are copied from the FIFO to the target memory (in raw data format). The "cnt" parameter indicates the number of entries to be copied from the FIFO. If the FIFO contains fewer data records, the entire content of the FIFO is copied. The number of entries actually copied is returned via the "entries" parameter. The function waits until at least one data record has been copied from the FIFO, though no longer than expiration of the timeout. In this case, zero is returned to "entries". Entire data packets are always copied from the FIFO. The target memory must be at least big enough to take the indicated number of FIFO entries. The content of an entry in FIFO corresponds to the currently configured data packet without the appended "fill bytes." All data words are saved in the "Little Endian" format.

Function

```
EIB7_ERR EIB7ReadFIFODataRaw ( EIB7_HANDLE      eib,
                               void*                data,
                               unsigned long        cnt,
                               unsigned long*       entries,
                               long                 timeout
                               )
```

Parameters

eib EIB handle
 data *[return code]* Pointer to target memory
 cnt Number of entries to be read (>= 0)
 entries *[return code]* Number of entries to be copied
 timeout Timeout in milliseconds

timeout	Description
0	Function returns immediately if no data is present
>0	Function waits for data for x milliseconds
-1	Function waits indefinitely

Return code

The return code delivers a status for the function call. In addition to the standard return codes, the following error messages can occur.

EIB7_FIFOEmpty No data in the FIFO
 EIB7_ElementSizeInv Internal error
 EIB7_FIFOOverflow FIFO overflow since the function was last called (data was lost)

7.45 Reading the Size of a FIFO Element

The size of a FIFO element in raw data format is generated. This value corresponds to the size of a FIFO entry, which is read using the EIB7ReadFIFODataRaw() function. A FIFO element contains a data packet whose size depends on the present configuration. The size is given without "fill bytes."

Function

```
EIB7_ERR EIB7SizeOfFIFOEntryRaw ( EIB7_HANDLE      eib,
                                   unsigned long*       size
                                   )
```

Parameters

eib EIB handle
 size *[return code]* Pointer to the variable for the size of a FIFO element in bytes

Return code

The return code delivers a status for the function call. All potential values are listed for the standard return codes.

7.46 Access to the Contents of a FIFO Element

This function can be used to access individual fields of a FIFO element (in raw data). A FIFO entry can contain, for example, the trigger counter, position data, the status word and additional data. The content of the data packet can vary depending on its configuration. When the elements are accessed, this must be remembered in order to interpret the data correctly. This function provides a pointer to the relevant field within the data structure and also the field size in bytes. A general selection is made using the "region" parameter. This makes it possible to select the axis from which the field is obtained. The fine selection can be made using the "type" parameter. This indicates which data field of an axis is to be accessed.

Function

```
EIB7_ERR EIB7GetDataFieldPtrRaw ( EIB7_HANDLE          eib,
                                  void*                data,
                                  EIB7_DataRegion      region,
                                  EIB7_PositionDataField type,
                                  void**               field,
                                  unsigned long*       size
                                  )
```

Parameters

eib EIB handle
 data Pointer to the data structure (FIFO element)
 region Axis of the EIB 74x

region	Description
EIB7_DR_Global	Global data field for trigger counter
EIB7_DR_Encoder1	Data for axis 1
EIB7_DR_Encoder2	Data for axis 2
EIB7_DR_Encoder3	Data for axis 3
EIB7_DR_Encoder4	Data for axis 4
EIB7_DR_AUX	Data for auxiliary axis

type Data element for an axis

type	Description
EIB7_PDF_TriggerCounter	Trigger counter (only in EIB7_DR_Global)
EIB7_PDF_StatusWord	Status word for position
EIB7_PDF_PositionData	Position value
EIB7_PDF_AUXPosition	Position value for auxiliary axis
EIB7_PDF_Timestamp	Timestamp for position
EIB7_PDF_Analog	ADC value for signals A and B
EIB7_PDF_ReferencePos	Reference position 1 and reference position 2
EIB7_PDF_DistCodedRef	Coded reference value
EIB7_PDF_EnDat_AI1	EnDat 2.2 additional datum 1
EIB7_PDF_EnDat_AI2	EnDat 2.2 additional datum 2

field *[return code]* Pointer to the memory address of the element from the data structure
 size *[return code]* Size of the element in bytes

Return code

The return code delivers a status for the function call. In addition to the standard return codes, the following error messages can occur.

EIB7_FieldNotAvail The indicated field cannot be found

7.47 Reading and Converting Data from the FIFO

Data packets are copied from the FIFO to the target memory and converted. The "cnt" parameter indicates the number of entries to be copied from the FIFO. If the FIFO contains fewer data records, the entire content of the FIFO is copied. The number of entries actually copied is returned via the "entries" parameter. The function waits until at least one data record has been copied from the FIFO, though no longer than expiration of the timeout. In this case, zero is returned to "entries". Entire data packets are always copied from the FIFO. The target memory must be at least big enough to take the indicated number of FIFO entries. The content of an entry corresponds to the currently configured data packet without the appended "fill bytes." All data words are saved in the standard format for 16-bit or 32-bit integers and the position values are converted to the ENCODER_POSITION format.

Function

```
EIB7_ERR EIB7ReadFIFOData      ( EIB7_HANDLE      eib,
                                void*          data,
                                unsigned long   cnt,
                                unsigned long*  entries,
                                long           timeout
                                )
```

Parameters

eib	EIB handle
data	<i>[return code]</i> Pointer to target memory
cnt	Number of entries to be read (>= 0)
entries	<i>[return code]</i> Number of entries to be copied
timeout	Timeout in milliseconds

timeout	Description
0	Function returns immediately if no data is present
>0	Function waits for data for x milliseconds
-1	Function waits indefinitely

Return code

The return code delivers a status for the function call. In addition to the standard return codes, the following error messages can occur.

EIB7_FIFOEmpty	No data in the FIFO
EIB7_ElementSizeInv	Internal error
EIB7_FIFOOverflow	FIFO overflow since the function was last called (data was lost)

7.48 Reading the Size of a FIFO Element Following Conversion

The size of a FIFO element is generated following conversion. This value corresponds to the size of a FIFO entry, which is read using the EIB7ReadFIFOData() function. A FIFO element contains a data packet whose size depends on the present configuration. The size is given without "fill bytes."

Function

```
EIB7_ERR EIB7SizeOfFIFOEntry    ( EIB7_HANDLE      eib,
                                unsigned long*  size
                                )
```

Parameters

eib	EIB handle
size	<i>[return code]</i> Pointer to the variable for the size of a FIFO element in bytes

Return code

The return code delivers a status for the function call. All potential values are listed for the standard return codes.

7.49 Access to the Contents of a FIFO Element with Converted Data

This function can be used to access individual fields of a FIFO element with converted position data (ENCODER_POSITION format). A FIFO entry can contain, for example, the trigger counter, position data, the status word and additional data. The content of the data packet can vary depending on its configuration. When the elements are accessed, this must be remembered in order to interpret the data correctly. This function provides a pointer to the relevant field within the data structure and also the field size in bytes. A general selection is made using the "region" parameter. This makes it possible to select the axis from which the field is obtained. The fine selection can be made using the "type" parameter. This indicates which data field of an axis is to be accessed.

Function

```
EIB7_ERR EIB7GetDataFieldPtr ( EIB7_HANDLE      eib,
                               void*            data,
                               EIB7_DataRegion  region,
                               EIB7_PositionDataField type,
                               void**          field,
                               unsigned long*   size
                               )
```

Parameters

eib EIB handle
 data Pointer to the data structure (FIFO element)
 region Axis of the EIB 74x

region	Description
EIB7_DR_Global	Global data field for trigger counter
EIB7_DR_Encoder1	Data for axis 1
EIB7_DR_Encoder2	Data for axis 2
EIB7_DR_Encoder3	Data for axis 3
EIB7_DR_Encoder4	Data for axis 4
EIB7_DR_AUX	Data for auxiliary axis

type Data element for an axis

type	Description
EIB7_PDF_TriggerCounter	Trigger counter (only in EIB7_DR_Global)
EIB7_PDF_StatusWord	Status word for position
EIB7_PDF_PositionData	Position value
EIB7_PDF_AUXPosition	Position value for auxiliary axis
EIB7_PDF_Timestamp	Timestamp for position
EIB7_PDF_Analog	ADC value for signals A and B
EIB7_PDF_ReferencePos	Reference position 1 and reference position 2
EIB7_PDF_DistCodedRef	Coded reference value
EIB7_PDF_EnDat_AI1	EnDat 2.2 additional datum 1
EIB7_PDF_EnDat_AI2	EnDat 2.2 additional datum 2

field *[return code]* Pointer to the memory address of the element from the data structure
 size *[return code]* Size of the element in bytes

Return code

The return code delivers a status for the function call. In addition to the standard return codes, the following error messages can occur.

EIB7_FieldNotAvail The indicated field cannot be found

7.50 Reading the Number of Elements in the FIFO

The number of elements currently stored in the FIFO is generated.

Function

```
EIB7_ERR EIB7FIFOEntryCount ( EIB7_HANDLE      eib,
                               unsigned long*   cnt
                               )
```

Parameters

eib EIB handle
 cnt *[return code]* Pointer to the variable for the number of FIFO elements

Return code

The return code delivers a status for the function call. All potential values are listed for the standard return codes.

7.51 Clearing the FIFO

The contents of the FIFO are cleared. This command has no effect if Polling mode is active.

Function

```
EIB7_ERR EIB7ClearFIFO      ( EIB7_HANDLE      eib
                             )
```

Parameters

eib EIB handle

Return code

The return code delivers a status for the function call. All potential values are listed for the standard return codes.

7.52 Setting the FIFO Size

The size of the FIFO is reestablished. All data in the FIFO is cleared. The size can only be set in Polling mode. The FIFO must be at least 2000 bytes large. If the value is smaller, the value of 2000 bytes is used internally.

Function

```
EIB7_ERR EIB7SetFIFOSize   ( EIB7_HANDLE      eib,
                             unsigned long      size
                             )
```

Parameters

eib EIB handle
size FIFO size in bytes

Return code

The return code delivers a status for the function call. In addition to the standard return codes, the following error messages can occur.

EIB7_SoftRTEn Soft Real-Time mode is activated

7.53 Reading the FIFO Size

The size of the FIFO in bytes is generated.

Function

```
EIB7_ERR EIB7GetFIFOSize   ( EIB7_HANDLE      eib,
                             unsigned long*     size
                             )
```

Parameters

eib EIB handle
size *[return code]* Pointer to the variable for the FIFO size in bytes

Return code

The return code delivers a status for the function call. All potential values are listed for the standard return codes.

7.54 Activating the Callback Mechanism

The callback mechanism is activated or deactivated and the function pointer saved where applicable. The callback function is called if there are at least as many elements saved in the FIFO as there are in the "threshold" parameter. This function will then not be called until new data has been written to the FIFO and then at least "threshold" elements have been saved in the FIFO.

Function

```
EIB7_ERR EIB7SetDataCallback ( EIB7_HANDLE      eib,
                               void*            data,
                               EIB7_MODE        activate,
                               unsigned long    threshold,
                               EIB7OnDataAvailable handler
                               )
```

Parameters

eib EIB handle
 data Pointer to user data, this pointer is transmitted as a parameter to the callback function
 activate Activate or deactivate callback

Activate	Description
EIB7_MD_Disable	Deactivate the callback mechanism
EIB7_MD_Enable	Activate the callback mechanism

threshold Number of elements in the FIFO from which the callback mechanism is triggered (> 0)
 handler Pointer to the callback function (NULL is permitted if activate = 0)

Return code

The return code delivers a status for the function call. All potential values are listed for the standard return codes.

Callback function

The callback function is performed by the driver and runs in a separate thread. The user must attend to any necessary synchronization with the main program. The "eib" parameter contains the handle to the EIB 74x that has triggered the callback. "cnt" indicates the number of elements currently stored in the FIFO. The "data" parameter contains the pointer that was indicated when registering the callback function.

Prototype

```
typedef void (*EIB7OnDataAvailable) ( EIB7_HANDLE      eib,
                                       unsigned long    cnt,
                                       void*            data
                                       )
```

Parameters

eib EIB handle
 cnt Number of elements in the FIFO
 data Pointer to user data

7.55 Selecting the Trigger Source for the Auxiliary Axis

The trigger signal for the auxiliary axis can be selected from different sources. This setting is possible only in the Polling mode.

Function

```
EIB7_ERR EIB7AuxAxisTriggerSource ( EIB7_HANDLE eib,
                                     EIB7_AxisTriggerSrc src
                                     )
```

Parameters

eib EIB handle
src Trigger source

src	Description
EIB7_AT_TrgInput1	Trigger input channel 1
EIB7_AT_TrgInput2	Trigger input channel 2
EIB7_AT_TrgInput3	Trigger input channel 3
EIB7_AT_TrgInput4	Trigger input channel 4
EIB7_AT_TrgSW1	Software trigger channel 1
EIB7_AT_TrgSW2	Software trigger channel 2
EIB7_AT_TrgSW3	Software trigger channel 3
EIB7_AT_TrgSW4	Software trigger channel 4
EIB7_AT_TrgRI	Reference pulse of the corresponding axis
EIB7_AT_TrgRImaskedCH1	Gated reference pulse of axis 1 (A&B&RI)
EIB7_AT_TrgIC	Interval counter
EIB7_AT_TrgPuls	Pulse-counter trigger
EIB7_AT_TrgTimer	Timer trigger

Return code

The return code delivers a status for the function call. In addition to the standard return codes, the following error messages can occur.

EIB7_ParamInvalid Parameter invalid

7.56 Reading the Position of the Auxiliary Axis

The current position value is read out. A status word informing about potential position errors is also transmitted. The position can only be polled in Polling mode. The setting of the interpolation factor and the edge evaluation for the interval counter determine the significance of an LSB (Lowest Significant Bit) in the position value with respect to the signal period of the encoder.

Function

```
EIB7_ERR EIB7AuxGetPosition ( EIB7_HANDLE eib,
                               unsigned short* status,
                               ENCODER_POSITION* pos
                               )
```

Parameters

eib EIB handle
status */return code/*Pointer to the target variable for the status word
pos */return code/*Pointer to the target variable for the position

Return code

The return code delivers a status for the function call. In addition to the standard return codes, the following error messages can occur.

EIB7_CantLatchPos Position cannot be determined
EIB7_EncPwrSuppErr Error in the encoder power supply
EIB7_NotInitialized Auxiliary axis is not configured

7.57 Reading Out the Data of the Auxiliary Axis

The current position and certain additional parameters are determined and read out. The function may only be performed in Polling mode. The status word indicates whether the position and the reference position are valid. The position value and the timestamp are saved simultaneously. This requires the internal use of software trigger channel 1. The trigger source for the auxiliary axis is configured accordingly, thereby overwriting the current setting.

Function

```
EIB7_ERR EIB7AuxGetEncoderData ( EIB7_HANDLE          eib,
                                unsigned short*       status,
                                ENCODER_POSITION*     pos,
                                ENCODER_POSITION*     ref,
                                unsigned long*        timestamp,
                                unsigned short*       counter
                                )
```

Parameters

eib	EIB handle
status	<i>[return code]</i> Pointer to the target variable for the status word
pos	<i>[return code]</i> Pointer to the target variable for the position
ref	<i>[return code]</i> Pointer to the target variable for the reference position
timestamp	<i>[return code]</i> Pointer to the target variable for the timestamp value
counter	<i>[return code]</i> Pointer to the target variable for the trigger counter

Return code

The return code delivers a status for the function call. In addition to the standard return codes, the following error messages can occur.

EIB7_CantLatchPos	Position cannot be determined
EIB7_EncPwrSuppErr	Error in the encoder power supply
EIB7_NotInitialized	Auxiliary axis is not configured

7.58 Clearing the Counter of the Auxiliary Axis

The position counter of the auxiliary axis is cleared.

Function

```
EIB7_ERR EIB7AuxClearCounter ( EIB7_HANDLE          eib
                                )
```

Parameters

eib	EIB handle
-----	------------

Return code

The return code delivers a status for the function call. All potential values are listed for the standard return codes.

7.59 Acknowledging the Signal Errors of the Auxiliary Axis

The error messages for the auxiliary axis are cleared. This applies to the error for the signal amplitude and the error for exceeding the frequency.

Function

```
EIB7_ERR EIB7AuxClearSignalErrors ( EIB7_HANDLE          eib
                                      )
```

Parameters

eib	EIB handle
-----	------------

Return code

The return code delivers a status for the function call. All potential values are listed for the standard return codes.

7.60 Acknowledging the Trigger Errors of the Auxiliary Axis

The error messages for undetected trigger events for the auxiliary axis in the trigger logic are cleared.

Function

```
EIB7_ERR EIB7AuxClearLostTriggerError ( EIB7_HANDLE eib
)
```

Parameters

eib EIB handle

Return code

The return code delivers a status for the function call. All potential values are listed for the standard return codes.

7.61 Clearing the Status Bit for the Reference Mark of the Auxiliary Axis

The "Reference position saved" flag in the status word for the auxiliary axis is reset.

Function

```
EIB7_ERR EIB7AuxClearRefStatus ( EIB7_HANDLE eib
)
```

Parameters

eib EIB handle

Return code

The return code delivers a status for the function call. All potential values are listed for the standard return codes.

7.62 Checking the Status of the Reference Run for the Auxiliary Axis

The status of the reference run is output. It indicates whether the reference run is still active, or the reference positions have already been saved.

Function

```
EIB7_ERR EIB7AuxGetRefActive ( EIB7_HANDLE eib,
                               EIB7_MODE* active
)
```

Parameters

eib EIB handle
 active *[return code]* Pointer to the variable for the status of the reference run

active	Description
EIB7_MD_Enable	Reference run active
EIB7_MD_Disable	Reference run not active

Return code

The return code delivers a status for the function call. All potential values are listed for the standard return codes.

7.63 Starting a Reference Run for the Auxiliary Axis

After this command has been called, the reference position is saved when the next reference pulse is traversed. The saved value corresponds to the period counter status at the reference mark position. The status of a previously saved reference position is set to invalid as soon as a reference run has been started.

Function

```
EIB7_ERR EIB7AuxStartRef ( EIB7_HANDLE eib
)
```

Parameters

eib EIB handle

Return code

The return code delivers a status for the function call. All potential values are listed for the standard return codes.

7.64 Stopping a Reference Run for the Auxiliary Axis

The reference run (mode for automatically saving the reference position) is stopped. Reference positions that have already been saved are not deleted.

Function

```
EIB7_ERR EIB7AuxStopRef      ( EIB7_HANDLE      eib
                               )
```

Parameters

eib EIB handle

Return code

The return code delivers a status for the function call. All potential values are listed for the standard return codes.

7.65 Configuring a Timestamp for the Auxiliary Axis

The timestamp can be activated or deactivated for the auxiliary axis. The global setting of the EIB 74x is used for the period duration. The timestamp value is copied during a position poll for the auxiliary axis if this function was activated beforehand.

Function

```
EIB7_ERR EIB7AuxSetTimestamp ( EIB7_HANDLE      eib,
                               EIB7_MODE        mode
                               )
```

Parameters

eib EIB handle
mode Activate or deactivate timestamp

mode	Description
EIB7_MD_Enable	Activate timestamp
EIB7_MD_Disable	Deactivate timestamp

Return code

The return code delivers a status for the function call. All potential values are listed for the standard return codes.

7.66 Setting the Trigger Edge for the Reference Pulse of the Auxiliary Axis

The time for reference-pulse triggering for the auxiliary axis can be set to the rising or falling edge or to both edges of the reference-pulse signal. If both edges are used for the trigger event, it must be ensured that the maximum trigger rate is not exceeded.

Function

```
EIB7_ERR EIB7AuxSetRITriggerEdge ( EIB7_HANDLE      eib,
                                    EIB7_RITriggerEdge    edge
                                    )
```

Parameters

eib EIB handle
edge Active trigger edge for the reference pulse

edge	Description
EIB7_RI_Rising	Rising edge of the reference pulse
EIB7_RI_Falling	Falling edge of the reference pulse
EIB7_RI_Both	Both edges of the reference pulse

Return code

The return code delivers a status for the function call. In addition to the standard return codes, the following error messages can occur.

EIB7_ParamInvalid Parameter invalid

8 Axis Functions

The axis functions always refer to just one axis on the EIB 74x. None of the other axes is affected.

All axis functions are able to deliver the following error messages as a return code. They can also return further values individually. These are listed separately for each function.

Standard return codes

EIB7_NoError	Function call successful
EIB7_InvalidHandle	The handle to the axis of the EIB 74x is invalid
EIB7_FuncNotSupp	Function is not supported by the EIB 74x
EIB7_InvalidResponse	Error during data transmission
EIB7_AccNotAllowed	Function cannot be performed, as the EIB 74x does not permit access
EIB7_ConnReset	Connection terminated by the EIB 74x
EIB7_ConnTimeout	Timeout during data transmission to the EIB 74x
EIB7_ReceiveError	Error while receiving the data
EIB7_SendError	Error while sending the data
EIB7_OutOfMemory	The system is unable to allocate sufficient memory

8.1 Initializing the Axis

An axis of the EIB 74x is configured for the connected encoder. The axis number of the EIB 74x is determined via the axis handle. The interface type of the encoder must be selected as a basic option. Certain parameters are required only for incremental interfaces and others only for EnDat interfaces. For an EnDat 2.2 interface, the delay compensation can also be activated using the "iface" parameter. To do this, the constants "EIB7_IT_EnDat22" and "EIB7_IT_EnDatDelayMeasurement" must be gated with "Or".

The "EnDatclock," "recovery" and "calculation" parameters are used only for encoders with the EnDat interface. The EnDat interface clock can be set. This must be done using pre-defined constants. Upon initialization of an axis for EnDat mode, an EnDat reset command is sent to the connected encoder. In addition, using the "recovery" parameter, the "recovery time I" can be set for EnDat 2.2 encoders (ordering designation EnDat02 or EnDat22). The "EnDat calculation time" has to be adjusted in the "calculation" parameter for the encoder.

The "bandwidth" and "comp" parameters are effective only for incremental encoders. Two states (high and low) are available for configuring the bandwidth. The online compensation function can be activated and deactivated. The values for "linecounts" and "increment" are required only in conjunction with distance-coded reference marks.

Calling this function clears the following flags:

- Signal amplitude error
- Frequency exceeded
- Reference position 1 saved
- Reference position 2 saved
- Coded reference value valid for distance-coded reference marks
- Error while calculating the coded reference value for distance-coded reference marks
- CRC error

The settings for the terminating resistors of the incremental signals as well as the value of the period counter are not influenced by the function.

Function

```

EIB7_ERR EIB7InitAxis      (  EIB7_AXIS      axis,
                               unsigned long  iface,
                               EIB7_EncoderType type,
                               EIB7_Refmarks  refmarks,
                               unsigned long  linecounts,
                               unsigned long  increment,
                               EIB7_Homing    homing,
                               EIB7_Limit     limit,
                               EIB7_Compensation comp,
                               EIB7_Bandwidth  bandwidth,
                               unsigned long  EnDatclock,
                               EIB7_EnDatRecoveryTime recovery,
                               EIB7_EnDatCalcTime calculation,
                               )
    
```

Parameters

axis AXIS handle
iface Interface type of the encoder

Iface	Description
EIB7_IT_Disabled	Axis deactivated
EIB7_IT_Incremental	Encoder with incremental signals (1 V _{PP})
EIB7_IT_Incremental_11u	Encoder with incremental signals (11 µA)
EIB7_IT_EnDat21	Encoder with EnDat 2.1 interface
EIB7_IT_EnDat01	Encoder with EnDat 2.1 interface and incremental signals (1 V _{PP})
EIB7_IT_EnDat22	Encoder with EnDat 2.2 interface
EIB7_IT_EnDatDelayMeasurement	Delay compensation for EnDat 2.2

type Encoder type

type	Description
EIB7_EC_Linear	Linear encoder
EIB7_EC_Rotary	Angle encoder / rotary encoder

refmarks Type of reference marks

Refmarks	Description
EIB7_RM_None	No reference mark
EIB7_RM_One	One reference mark (EIB 74x does not calculate a coded reference value)
EIB7_RM_DistanceCoded	Distance-coded reference marks (EIB 74x calculates coded reference value automatically)

linecounts Number of signal periods per revolution (only for rotary encoders)

increment Nominal distance in signal periods between two fixed reference marks (only for distance-coded reference marks)

homing Activate or deactivate evaluation of the homing signal

homing	Description
EIB7_HS_None	Homing signal is not evaluated
EIB7_HS_Available	Homing signal is evaluated

limit Activate or deactivate evaluation of the limit signal

limit	Description
EIB7_LS_None	Limit signal is not evaluated
EIB7_LS_Available	Limit signal is evaluated

compensation Activate or deactivate online compensation

Compensation	Description
EIB7_CS_None	Signal compensation deactivated
EIB7_CS_CompActive	Signal compensation activated

bandwidth Input bandwidth for incremental signals (high/low)

Bandwidth	Description
EIB7_BW_High	High input bandwidth for 1 V _{PP} signals
EIB7_BW_Low	Low input bandwidth for 1 V _{PP} signals

EnDatclock EnDat clock rate

EnDatclock	Description
EIB7_CLK_Default	Default EnDat 2.1 / EnDat 2.2 clock
EIB7_CLK_100KHz	EnDat clock 100 kHz
EIB7_CLK_300KHz	EnDat clock 300 kHz (default for EnDat 2.1)
EIB7_CLK_500KHz	EnDat clock 500 kHz
EIB7_CLK_1MHz	EnDat clock 1 MHz
EIB7_CLK_2MHz	EnDat clock 2 MHz (default for EnDat 2.2)
EIB7_CLK_4MHz	EnDat clock 4 MHz
EIB7_CLK_5MHz	EnDat clock 5 MHz
EIB7_CLK_6_66MHz	EnDat clock 6.66 MHz

recovery Recovery time I for EnDat 2.2

recovery	Description
EIB7_RT_Long	Long recovery time I according to the EnDat specification
EIB7_RT_Short	Short recovery time I according to the EnDat specification

calculation Calculation time for EnDat

calculation	Description
EIB7_CT_Long	Long calculation time
EIB7_CT_Short	Short calculation time

Return code

The return code delivers a status for the function call. In addition to the standard return codes, the following error messages can occur.

EIB7_ParamInvalid	Parameter invalid
EIB7_InvInterface	Interface type invalid
EIB7_InvRefMarkOpt	Reference mark invalid
EIB7_InvDistCodeRef	Parameter for distance-coded reference marks invalid (line count, increment)
EIB7_ConfOptIncons	Parameters cannot be combined in this form
EIB7_AccNotAllowed	Access denied
EIB7_EncPwrSuppErr	Error in the encoder power supply (encoder is not ready for operation)

Note:

If the axis is configured for EnDat (EnDat01, EnDat21, EnDat22), up to firmware version 9 the EnDat error messages and warnings were cleared upon execution of "EIB7InitAxis". As of firmware version 10 the error messages and warnings are not cleared. The reason for this is the error handling for battery-buffered encoders (also see EnDat Application Notes).

8.2 Selecting the Trigger Source for the Axis

The trigger signal for the axis can be selected from different sources. This setting is possible only in the Polling mode.

Function

```
EIB7_ERR EIB7AxisTriggerSource ( EIB7_AXIS          axis,
                                EIB7_AxisTriggerSrc  src
                                )
```

Parameters

axis AXIS handle
src Trigger source

src	Description
EIB7_AT_TrgInput1	Trigger input channel 1
EIB7_AT_TrgInput2	Trigger input channel 2
EIB7_AT_TrgInput3	Trigger input channel 3
EIB7_AT_TrgInput4	Trigger input channel 4
EIB7_AT_TrgSW1	Software trigger channel 1
EIB7_AT_TrgSW2	Software trigger channel 2
EIB7_AT_TrgSW3	Software trigger channel 3
EIB7_AT_TrgSW4	Software trigger channel 4
EIB7_AT_TrgRI	Reference pulse of the corresponding axis
EIB7_AT_TrgRImaskedCH1	Gated reference pulse of axis 1 (A&B&RI)
EIB7_AT_TrgIC	Interval counter
EIB7_AT_TrgPuls	Pulse-counter trigger
EIB7_AT_TrgTimer	Timer trigger

Return code

The return code delivers a status for the function call. In addition to the standard return codes, the following error messages can occur.

EIB7_ParamInvalid Parameter invalid

8.3 Setting the Trigger Edge for the Reference Pulse

The time for reference-pulse triggering can be set to the rising or falling edge or to both edges of the reference-pulse signal. If both edges are used for the trigger event, it must be ensured that the maximum trigger rate is not exceeded.

Function

```
EIB7_ERR EIB7SetRITriggerEdge ( EIB7_AXIS          axis,
                                EIB7_RITriggerEdge  edge
                                )
```

Parameters

axis AXIS handle
edge Active trigger edge for the reference pulse

edge	Description
EIB7_RI_Rising	Rising edge of the reference pulse
EIB7_RI_Falling	Falling edge of the reference pulse
EIB7_RI_Both	Both edges of the reference pulse

Return code

The return code delivers a status for the function call. In addition to the standard return codes, the following error messages can occur.

EIB7_ParamInvalid Parameter invalid

8.4 Clearing the Counter

The period counter of an axis is cleared. This function is permitted only if the axis is configured for incremental encoders. Otherwise an error message is generated. Only the period counter is reset. The interpolation value is not changed.

Function

```
EIB7_ERR EIB7ClearCounter ( EIB7_AXIS axis
                           )
```

Parameters

axis AXIS handle

Return code

The return code delivers a status for the function call. In addition to the standard return codes, the following error messages can occur.

EIB7_InvInterface Interface type invalid

8.5 Interrogating a Position

The encoder's current position value is determined and read. A status word informing about potential position errors is also transmitted. The position can only be polled in Polling mode. Depending on whether the axis is configured for incremental or for EnDat encoders, the interpolated value of the incremental signals is provided or an EnDat request is sent to the encoder. With EnDat 01 configuration, the interpolated value of the incremental signals is read.

Function

```
EIB7_ERR EIB7GetPosition ( EIB7_AXIS axis,
                           unsigned short* status,
                           ENCODER_POSITION* pos
                           )
```

Parameters

axis AXIS handle
status [return code] Pointer to the variable for the status word
pos [return code] Pointer to the variable for the position

Return code

The return code delivers a status for the function call. In addition to the standard return codes, the following error messages can occur.

EIB7_CantLatchPos Position cannot be determined
EIB7_EncPwrSuppErr Error in the encoder power supply (EnDat encoders only)
EIB7_NotInitialized Axis is not configured

8.6 Reading out Data for a Channel

The current position and certain additional parameters are determined and read. The "refc" parameter is valid only if the axis is configured for encoders with distance-coded reference marks. The function may only be performed in Polling mode. The axis must be configured for incremental encoders. The position value and the timestamp are saved simultaneously. This requires the internal use of software trigger channel 1. The trigger source for the auxiliary axis is configured accordingly, thereby overwriting the current setting.

Function

```
EIB7_ERR EIB7GetEncoderData ( EIB7_AXIS axis,
                              unsigned short* status,
                              ENCODER_POSITION* pos,
                              ENCODER_POSITION* ref1,
                              ENCODER_POSITION* ref2,
                              ENCODER_POSITION* refc,
                              unsigned long* timestamp,
                              unsigned short* counter,
                              unsigned short* adc00,
                              unsigned short* adc90
                              )
```

Parameters

axis	AXIS handle
status	<i>[return code]</i> Pointer to the variable for the status word
pos	<i>[return code]</i> Pointer to the variable for the position
ref1	<i>[return code]</i> Pointer to the variable for reference position 1
ref2	<i>[return code]</i> Pointer to the variable for reference position 2
refc	<i>[return code]</i> Pointer to the variable for the coded reference value
timestamp	<i>[return code]</i> Pointer to the variable for the timestamp value
counter	<i>[return code]</i> Pointer to the variable for the trigger counter
adc00	<i>[return code]</i> Pointer to the variable for the ADC value for signal A
adc90	<i>[return code]</i> Pointer to the variable for the ADC value for signal B

Return code

The return code delivers a status for the function call. In addition to the standard return codes, the following error messages can occur.

EIB7_ParamInvalid	Parameter invalid (axis is possibly not configured for incremental encoders)
EIB7_EncPwrSuppErr	Error in the encoder power supply (EnDat encoders only)
EIB7_NotInitialized	Axis is not configured

8.7 Acknowledging the Power Supply Error

The error message for the power supply to the encoder is acknowledged. If no error has occurred for this axis, the function is terminated with an error message. The encoder power supply is switched back on once the error has been acknowledged.

Function

```
EIB7_ERR EIB7ClearPowerSupplyError ( EIB7_AXIS axis
                                      )
```

Parameter

axis	AXIS handle
------	-------------

Return code

The return code delivers a status for the function call. In addition to the standard return codes, the following error messages can occur.

EIB7_CantClearEnc	Error cannot be cleared
-------------------	-------------------------

8.8 Acknowledging the Trigger Error

The error message for the trigger interface is acknowledged. The trigger error is cleared for all axes of an EIB 74x at the same time, regardless of which AXIS handle is transferred.

Function

```
EIB7_ERR EIB7ClearLostTriggerError ( EIB7_AXIS axis )
```

Parameter

axis AXIS handle

Return code

The return code delivers a status for the function call. All potential values are listed for the standard return codes.

8.9 Acknowledging the Signal Error

The error messages for the signals of the encoder are cleared. With incremental encoders, the errors for the signal amplitude and for exceeding the frequency are acknowledged. With EnDat encoders, the CRC error for data transfer and the EnDat error messages are cleared. The error memory in the encoder is not affected. No EnDat command is sent.

Function

```
EIB7_ERR EIB7ClearEncoderErrors ( EIB7_AXIS axis )
```

Parameter

axis AXIS handle

Return code

The return code delivers a status for the function call. All potential values are listed for the standard return codes.

8.10 Clearing EnDat Error Bits

The EnDat error flags are cleared. This function is permitted only for axes configured for EnDat encoders. An EnDat reset command is sent to the EnDat encoder to clear the error memory. After the reset command, the function waits for 50 ms in accordance with the EnDat specification. This function may only be performed in Polling mode.

Function

```
EIB7_ERR EIB7ClearEnDatErrorMsg ( EIB7_AXIS axis )
```

Parameter

axis AXIS handle

Return code

The return code delivers a status for the function call. In addition to the standard return codes, the following error messages can occur.

EIB7_InvInterface	Axis is not configured for EnDat
EIB7_EncPwrSuppErr	Error in the encoder power supply
EIB7_NotInitialized	Axis is not configured

8.11 Clearing Status Bits for Reference Marks

The flags for the reference position in the status word are reset. The following flags are reset: "Reference position 1 saved", "Reference position 2 saved". This command is permitted only for axes configured for incremental encoders with reference marks.

Function

```
EIB7_ERR EIB7ClearRefLatched ( EIB7_AXIS axis
                               )
```

Parameter

axis AXIS handle

Return code

The return code delivers a status for the function call. In addition to the standard return codes, the following error messages can occur.

EIB7_InvInterface Axis is not configured for incremental encoders
EIB7_NotInitialized Axis is not configured

8.12 Clearing Status Bits for Distance-Coded Reference Marks

The flags for the reference position in the status word are reset. The following flags are reset: "Reference position 1 saved", "Reference position 2 saved", "Coded reference value valid", "Error on calculating the coded reference value". This command is permitted only for axes configured for encoders with distance-coded reference marks.

Function

```
EIB7_ERR EIB7ClearRefStatus ( EIB7_AXIS axis
                               )
```

Parameter

axis AXIS handle

Return code

The return code delivers a status for the function call. In addition to the standard return codes, the following error messages can occur.

EIB7_InvInterface Axis is not configured for incremental encoders
EIB7_NotInitialized Axis is not configured

8.13 Starting the Reference Run

After this command has been called, the reference position is saved when the next reference pulse is traversed. The "ref" parameter can be used to define whether only one or two reference positions are saved. If two reference positions are activated, one position value is saved with each of the two subsequent reference pulses. The saved values correspond to the period counter status at the respective reference mark position. This command is permitted only for axes configured for incremental encoders.

If this function is called again before all reference positions from the first call have been saved, the old reference position values become invalid and this is indicated by the flags in the status word. The reference run is restarted.

Function

```
EIB7_ERR EIB7StartRef ( EIB7_AXIS axis,
                        EIB7_ReferencePosition ref
                        )
```

Parameter

axis AXIS handle
ref Option for the reference position to be saved

Ref	Description
EIB7_RP_RefPos1	Save one reference position
EIB7_RP_RefPos2	Save two reference positions

Return code

The return code delivers a status for the function call. In addition to the standard return codes, the following error messages can occur.

EIB7_InvInterface Axis is not configured for incremental encoders
EIB7_NotInitialized Axis is not configured
EIB7_ParamInvalid Parameter is not a valid option for the reference marks

8.14 Stopping the Reference Run

The reference run (mode for automatically saving the reference position) is stopped. If reference pulses have already been crossed, the corresponding position values will be retained. This command is permitted only for axes configured for incremental encoders.

Function

```
EIB7_ERR EIB7StopRef ( EIB7_AXIS axis )
```

Parameter

axis AXIS handle

Return code

The return code delivers a status for the function call. In addition to the standard return codes, the following error messages can occur.

```
EIB7_InvInterface       Axis is not configured for incremental encoders
EIB7_NotInitialized     Axis is not configured
EIB7_ParamInvalid        Invalid parameter for axis
```

8.15 Verifying the Status of the Reference Run

The status of the reference run is output. This enables the user to check whether the reference run is still active or all reference positions have already been saved.

Function

```
EIB7_ERR EIB7GetRefActive ( EIB7_AXIS axis,
                             EIB7_MODE* active
                           )
```

Parameter

axis AXIS handle
active *[return code]* Pointer to the variable for the status

mode	Description
EIB7_MD_Disable	Reference run complete
EIB7_MD_Enable	Reference run active

Return code

The return code delivers a status for the function call. All potential values are listed for the standard return codes.

8.16 Activating the Monitoring of the Reference Marks

Monitoring of the reference mark can be activated for incremental encoders. A tolerance value can also be indicated. This value specifies the maximum permissible deviation from the nominal value of the reference position.

Function

```
EIB7_ERR EIB7SetReferenceCheck ( EIB7_AXIS axis,
                                  EIB7_MODE mode,
                                  unsigned long limit
                                )
```

Parameters

axis AXIS handle
mode Activate or deactivate the check of the reference marks

mode	Description
EIB7_MD_Enable	Activate the check
EIB7_MD_Disable	Deactivate the check

limit Maximum deviation between two reference positions in signal periods

Return code

The return code delivers a status for the function call. In addition to the standard return codes, the following error messages can occur.

```
EIB7_InvalidInterface   Axis is not configured for incremental encoders
EIB7_ParamInvalid        Parameter invalid
```

8.17 EnDat 2.1: Reading the Position

The position of an EnDat encoder is read. This occurs via an EnDat 2.1 command. This function may only be performed in Polling mode. The axis must be configured for EnDat01, EnDat21 or EnDat22 encoders. The position is always requested via an EnDat 2.1 command, even if the axis is configured for EnDat 2.2.

Function

```
EIB7_ERR EIB7EnDat21GetPosition ( EIB7_AXIS axis,
                                unsigned short* status,
                                ENCODER_POSITION* pos
                                )
```

Parameters

axis	AXIS handle
status	<i>[return code]</i> Pointer to the variable for the status word
pos	<i>[return code]</i> Pointer to the variable for the position value

Return code

The return code delivers a status for the function call. In addition to the standard return codes, the following error messages can occur.

EIB7_InvInterface	Axis is not configured for EnDat encoders
EIB7_NotInitialized	Axis is not initialized
EIB7_EncPwrSuppErr	Error in the encoder power supply (encoder is not ready for operation)
EIB7_EnDatErrII	Type II EnDat error occurred
EIB7_EnDatIfBusy	EnDat master not ready for operation
EIB7_EnDatXmitErr	Error during data transmission (encoder might not be connected)

8.18 EnDat 2.1: Selecting the Memory Area

The memory area in the EnDat encoder is selected. An EnDat 2.1 command is sent for this purpose. This function may only be performed in Polling mode. The axis must be configured for EnDat01, EnDat21 or EnDat22 encoders. The memory area is always selected via an EnDat 2.1 command, even if the axis is configured for EnDat 2.2.

Function

```
EIB7_ERR EIB7EnDat21SelectMemRange ( EIB7_AXIS axis,
                                      unsigned char mrs
                                      )
```

Parameters

axis	AXIS handle
mrs	MRS code for the memory area

Return code

The return code delivers a status for the function call. In addition to the standard return codes, the following error messages can occur.

EIB7_InvInterface	Axis is not configured for EnDat encoders
EIB7_NotInitialized	Axis is not initialized
EIB7_EncPwrSuppErr	Error in the encoder power supply (encoder is not ready for operation)
EIB7_EnDatErrII	Type II EnDat error occurred
EIB7_EnDatIfBusy	EnDat master not ready for operation
EIB7_EnDatXmitErr	Error during data transmission (encoder might not be connected)

8.19 EnDat 2.1: Sending Data

A data word is written to the memory of the EnDat encoder. 16-bit words are always saved. The address indicates the memory cell within the active memory block. This function may only be performed in Polling mode. The axis must be configured for EnDat01, EnDat21 or EnDat22 encoders. An EnDat 2.1 command is always sent, even if the axis is configured for EnDat 2.2.

Function

```
EIB7_ERR EIB7EnDat21WriteMem ( EIB7_AXIS axis,
                               unsigned char addr,
                               unsigned short data
                             )
```

Parameters

axis	AXIS handle
addr	Memory address within the active memory block
data	Data word that is written to the memory

Return code

The return code delivers a status for the function call. In addition to the standard return codes, the following error messages can occur.

EIB7_InvInterface	Axis is not configured for EnDat encoders
EIB7_NotInitialized	Axis is not initialized
EIB7_EncPwrSuppErr	Error in the encoder power supply (encoder is not ready for operation)
EIB7_EnDatErrII	Type II EnDat error occurred
EIB7_EnDatIfBusy	EnDat master not ready for operation
EIB7_EnDatXmitErr	Error during data transmission (encoder might not be connected)

8.20 EnDat 2.1: Receiving Data

A data word is read from the memory of the EnDat encoder. A 16-bit word is always saved. The "addr" parameter indicates the memory cell within the active memory block from which the data is read. This function may only be performed in Polling mode. The axis must be configured for EnDat01, EnDat21 or EnDat22 encoders. An EnDat 2.1 command is always sent, even if the axis is configured for EnDat 2.2.

Function

```
EIB7_ERR EIB7EnDat21ReadMem ( EIB7_AXIS axis,
                               unsigned char addr,
                               unsigned short* data
                             )
```

Parameters

axis	AXIS handle
addr	Memory address within the active memory block
data	<i>[return code]</i> Pointer to the variable for the received data word

Return code

The return code delivers a status for the function call. In addition to the standard return codes, the following error messages can occur.

EIB7_InvInterface	Axis is not configured for EnDat encoders
EIB7_NotInitialized	Axis is not initialized
EIB7_EncPwrSuppErr	Error in the encoder power supply (encoder is not ready for operation)
EIB7_EnDatErrII	Type II EnDat error occurred
EIB7_EnDatIfBusy	EnDat master not ready for operation
EIB7_EnDatXmitErr	Error during data transmission (encoder might not be connected)

8.21 EnDat 2.1: Resetting the Encoder

The EnDat reset command is sent to the encoder. This function may only be performed in Polling mode. The axis must be configured for EnDat01, EnDat21 or EnDat22 encoders. An EnDat 2.1 reset is always sent, even if the axis is configured for EnDat 2.2. The encoder performs a reset and is unavailable for a certain time. Additional information can be found in the data sheet for the encoder.

Function

```
EIB7_ERR EIB7EnDat21ResetEncoder ( EIB7_AXIS axis )
```

Parameter

axis AXIS handle

Return code

The return code delivers a status for the function call. In addition to the standard return codes, the following error messages can occur.

EIB7_InvInterface	Axis is not configured for EnDat encoders
EIB7_NotInitialized	Axis is not initialized
EIB7_EncPwrSuppErr	Error in the encoder power supply (encoder is not ready for operation)
EIB7_EnDatErrll	Type II EnDat error occurred
EIB7_EnDatIfBusy	EnDat master not ready for operation
EIB7_EnDatXmitErr	Error during data transmission (encoder might not be connected)

8.22 EnDat 2.1: Reading the Test Value

A test value is read from the EnDat encoder. The test value is 40 bits long and is returned via two parameters. The contents of the parameters are listed in the table below. This function may only be performed in Polling mode. The axis must be configured for EnDat01, EnDat21 or EnDat22 encoders. An EnDat 2.1 command is always sent, even if the axis is configured for EnDat 2.2.

Parameter	Data bit parameter	Data bit test value
low	D0 to D31	D0 to D31
high	D0 to D7 D8 to D31	D32 to D39 Reserved

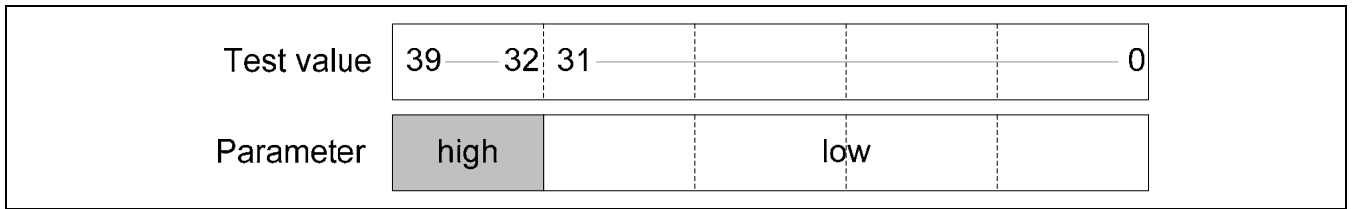

Figure 1: Data bit test value

Function

```
EIB7_ERR EIB7EnDat21ReadTestValue ( EIB7_AXIS axis,
                                     unsigned long* high,
                                     unsigned long* low )
```

Parameters

axis AXIS handle
high *[return code]* Pointer to the variable for the test value (most significant part)
low *[return code]* Pointer to the variable for the test value (least significant part)

Return code

The return code delivers a status for the function call. In addition to the standard return codes, the following error messages can occur.

EIB7_InvInterface	Axis is not configured for EnDat encoders
EIB7_NotInitialized	Axis is not initialized
EIB7_EncPwrSuppErr	Error in the encoder power supply (encoder is not ready for operation)
EIB7_EnDatErrll	Type II EnDat error occurred
EIB7_EnDatIfBusy	EnDat master not ready for operation
EIB7_EnDatXmitErr	Error during data transmission (encoder might not be connected)

8.23 EnDat 2.1: Sending Test Command to Encoder

A test command is sent to the EnDat encoder. The port address for the test command can be indicated using the "port" parameter. The axis must be configured for EnDat01, EnDat21 or EnDat22 encoders. An EnDat 2.1 command is always sent, even if the axis is configured for EnDat 2.2.

Function

```
EIB7_ERR EIB7EnDat21WriteTestCommand ( EIB7_AXIS axis,
                                       unsigned char port
                                       )
```

Parameters

axis	AXIS handle
port	Port address for the test command

Return code

The return code delivers a status for the function call. In addition to the standard return codes, the following error messages can occur.

EIB7_InvInterface	Axis is not configured for EnDat encoders
EIB7_NotInitialized	Axis is not initialized
EIB7_EncPwrSuppErr	Error in the encoder power supply (encoder is not ready for operation)
EIB7_EnDatErrII	Type II EnDat error occurred
EIB7_EnDatIfBusy	EnDat master not ready for operation
EIB7_EnDatXmitErr	Error during data transmission (encoder might not be connected)

8.24 EnDat 2.2: Reading the Position and Additional Datum

The position of an EnDat22 encoder is read. If activated, the EnDat additional datum is also transmitted. Each additional datum consists of a status word and the data word. The status word labels the data as valid or invalid and specifies the contents of the additional datum. This function may only be performed in Polling mode. The axis must be configured for EnDat22 encoders.

Function

```
EIB7_ERR EIB7EnDat22GetPosition ( EIB7_AXIS axis,
                                  unsigned short* status,
                                  ENCODER_POSITION* pos,
                                  ENDAT_ADDINFO* ai1,
                                  ENDAT_ADDINFO* ai2
                                  )
```

Parameters

axis	AXIS handle
status	<i>[return code]</i> Pointer to the variable for the status word
pos	<i>[return code]</i> Pointer to the variable for the position value
ai1	<i>[return code]</i> Pointer to the structure for the EnDat additional datum 1
ai2	<i>[return code]</i> Pointer to the structure for the EnDat additional datum 2

Return code

The return code delivers a status for the function call. In addition to the standard return codes, the following error messages can occur.

EIB7_InvInterface	Axis is not configured for EnDat encoders
EIB7_NotInitialized	Axis is not initialized
EIB7_EncPwrSuppErr	Error in the encoder power supply (encoder is not ready for operation)
EIB7_EnDatErrII	Type II EnDat error occurred
EIB7_EnDatIfBusy	EnDat master not ready for operation
EIB7_EnDatXmitErr	Error during data transmission (encoder might not be connected)
EIB7_EnDat22NotSupp	The encoder does not support EnDat 2.2 commands or the axis is not configured for EnDat 2.2 mode

8.25 EnDat 2.2: Reading the Position and Additional Datum and Selecting the Memory Area

The position and additional datum of an EnDat22 encoder are transmitted as described in section 8.24. The encoder activates the memory area, which is determined using the MRS code and the block address. If no block is selected from the "section 2" memory area, the "block" parameter must be set to zero. This function may only be performed in Polling mode. The axis must be configured for EnDat22 encoders.

Function

```
EIB7_ERR EIB7EnDat22SelectMemRange ( EIB7_AXIS      axis,
                                     unsigned short*   status,
                                     ENCODER_POSITION* pos,
                                     ENDAT_ADDINFO*   ai1,
                                     ENDAT_ADDINFO*   ai2,
                                     unsigned char     mrs,
                                     unsigned char     block
                                     )
```

Parameters

axis	AXIS handle
status	<i>[return code]</i> Pointer to the variable for the status word
pos	<i>[return code]</i> Pointer to the variable for the position value
ai1	<i>[return code]</i> Pointer to the structure for the EnDat additional datum 1
ai2	<i>[return code]</i> Pointer to the structure for the EnDat additional datum 2
mrs	MRS code for the memory area
block	Block address for the "section 2" memory areas

Return code

The return code delivers a status for the function call. In addition to the standard return codes, the following error messages can occur.

EIB7_InvInterface	Axis is not configured for EnDat encoders
EIB7_NotInitialized	Axis is not initialized
EIB7_EncPwrSuppErr	Error in the encoder power supply (encoder is not ready for operation)
EIB7_EnDatErrII	Type II EnDat error occurred
EIB7_EnDatIfBusy	EnDat master not ready for operation
EIB7_EnDatXmitErr	Error during data transmission (encoder might not be connected)
EIB7_EnDat22NotSupp	The encoder does not support EnDat 2.2 commands or the axis is not configured for EnDat 2.2 mode

8.26 EnDat 2.2: Reading the Position and Additional Datum and Sending Data

The position and additional datum of an EnDat22 encoder are transmitted as described in section 8.24. The 16-bit data word is written to the memory of the encoder. The address (8-bit) indicates the memory cell within the selected memory area. This function may only be performed in Polling mode. The axis must be configured for EnDat22 encoders.

Function

```
EIB7_ERR EIB7EnDat22WriteMem ( EIB7_AXIS      axis,
                                unsigned short* status,
                                ENCODER_POSITION* pos,
                                ENDAT_ADDINFO*   ai1,
                                ENDAT_ADDINFO*   ai2,
                                unsigned char     addr,
                                unsigned short    data
                                )
```

Parameters

axis	AXIS handle
status	<i>[return code]</i> Pointer to the variable for the status word
pos	<i>[return code]</i> Pointer to the variable for the position value
ai1	<i>[return code]</i> Pointer to the structure for the EnDat additional datum 1
ai2	<i>[return code]</i> Pointer to the structure for the EnDat additional datum 2
addr	Memory address within the active memory block
data	Data word that is written to the memory

Return code

The return code delivers a status for the function call. In addition to the standard return codes, the following error messages can occur.

EIB7_InvInterface	Axis is not configured for EnDat encoders
EIB7_NotInitialized	Axis is not initialized
EIB7_EncPwrSuppErr	Error in the encoder power supply (encoder is not ready for operation)
EIB7_EnDatErrII	Type II EnDat error occurred
EIB7_EnDatIfBusy	EnDat master not ready for operation
EIB7_EnDatXmitErr	Error during data transmission (encoder might not be connected)
EIB7_EnDat22NotSupp	The encoder does not support EnDat 2.2 commands or the axis is not configured for EnDat 2.2 mode

8.27 EnDat 2.2: Reading the Position and Additional Datum and Receiving Data

The position and additional datum of an EnDat22 encoder are transmitted as described in section 8.24. The encoder reads a data word from its memory; the address of the memory cell inside the selected memory area is specified using the "addr" parameter. The data is transmitted via the additional datum and cannot be read until the next EnDat command. The appropriate additional datum must be selected (see EnDat specification). This function may only be performed in Polling mode. The axis must be configured for EnDat22 encoders.

Function

```
EIB7_ERR EIB7EnDat22ReadMem ( EIB7_AXIS      axis,
                              unsigned short*  status,
                              ENCODER_POSITION* pos,
                              ENDAT_ADDINFO*   ai1,
                              ENDAT_ADDINFO*   ai2,
                              unsigned char    addr
                              )
```

Parameters

axis	AXIS handle
status	<i>[return code]</i> Pointer to the variable for the status word
pos	<i>[return code]</i> Pointer to the variable for the position value
ai1	<i>[return code]</i> Pointer to the structure for the EnDat additional datum 1
ai2	<i>[return code]</i> Pointer to the structure for the EnDat additional datum 2
addr	Memory address within the active memory block

Return code

The return code delivers a status for the function call. In addition to the standard return codes, the following error messages can occur.

EIB7_InvInterface	Axis is not configured for EnDat encoders
EIB7_NotInitialized	Axis is not initialized
EIB7_EncPwrSuppErr	Error in the encoder power supply (encoder is not ready for operation)
EIB7_EnDatErrII	Type II EnDat error occurred
EIB7_EnDatIfBusy	EnDat master not ready for operation
EIB7_EnDatXmitErr	Error during data transmission (encoder might not be connected)
EIB7_EnDat22NotSupp	The encoder does not support EnDat 2.2 commands or the axis is not configured for EnDat 2.2 mode

8.28 EnDat 2.2: Reading the Position and Additional Datum and Sending the Test Command

The position and additional datum of an EnDat22 encoder are transmitted as described in section 8.24. The "port" parameter contains the port address for the test command. This function may only be performed in Polling mode. The axis must be configured for EnDat22 encoders.

Function

```
EIB7_ERR EIB7EnDat22WriteTestCommand ( EIB7_AXIS      axis,
                                        unsigned short*  status,
                                        ENCODER_POSITION* pos,
                                        ENDAT_ADDINFO*   ai1,
                                        ENDAT_ADDINFO*   ai2,
                                        unsigned char    port
                                        )
```

Parameters

axis	AXIS handle
status	<i>[return code]</i> Pointer to the variable for the status word
pos	<i>[return code]</i> Pointer to the variable for the position value
ai1	<i>[return code]</i> Pointer to the structure for the EnDat additional datum 1
ai2	<i>[return code]</i> Pointer to the structure for the EnDat additional datum 2
port	Port address for the test command

Return code

The return code delivers a status for the function call. In addition to the standard return codes, the following error messages can occur.

EIB7_InvInterface	Axis is not configured for EnDat encoders
EIB7_NotInitialized	Axis is not initialized
EIB7_EncPwrSuppErr	Error in the encoder power supply (encoder is not ready for operation)
EIB7_EnDatErrII	Type II EnDat error occurred
EIB7_EnDatIfBusy	EnDat master not ready for operation
EIB7_EnDatXmitErr	Error during data transmission (encoder might not be connected)
EIB7_EnDat22NotSupp	The encoder does not support EnDat 2.2 commands or the axis is not configured for EnDat 2.2 mode

8.29 EnDat 2.2: Reading the Position and Additional Datum and Transmitting the Error Reset

The position and additional datum of an EnDat22 encoder are transmitted as described in section 8.24. The error memory of the EnDat22 encoder is also cleared. This function may only be performed in Polling mode. The axis must be configured for EnDat22 encoders.

Function

```
EIB7_ERR EIB7EnDat22ErrorReset ( EIB7_AXIS axis,  
                                unsigned short* status,  
                                ENCODER_POSITION* pos,  
                                ENDAT_ADDINFO* ai1,  
                                ENDAT_ADDINFO* ai2,  
                                )
```

Parameters

axis	AXIS handle
status	<i>[return code]</i> Pointer to the variable for the status word
pos	<i>[return code]</i> Pointer to the variable for the position value
ai1	<i>[return code]</i> Pointer to the structure for the EnDat additional datum 1
ai2	<i>[return code]</i> Pointer to the structure for the EnDat additional datum 2

Return code

The return code delivers a status for the function call. In addition to the standard return codes, the following error messages can occur.

EIB7_InvInterface	Axis is not configured for EnDat encoders
EIB7_NotInitialized	Axis is not initialized
EIB7_EncPwrSuppErr	Error in the encoder power supply (encoder is not ready for operation)
EIB7_EnDatErrII	Type II EnDat error occurred
EIB7_EnDatIfBusy	EnDat master not ready for operation
EIB7_EnDatXmitErr	Error during data transmission (encoder might not be connected)
EIB7_EnDat22NotSupp	The encoder does not support EnDat 2.2 commands or the axis is not configured for EnDat 2.2 mode

8.30 EnDat 2.2: Selecting the Additional Datum

The additional data for an EnDat 2.2 encoder can be configured. The configuration must be in the Polling mode. The additional data is transmitted in the Soft Real-Time, Streaming, and Recording modes.

The corresponding additional datum is selected in the encoder during a change from the Polling mode to another mode. It also remains possible to transmit only additional datum 1 or additional datum 2. To deactivate an additional datum, EIB7_AI1_Stop or EIB7_AI2_Stop must be transmitted as a parameter.

Function

```
EIB7_ERR EIB7EnDat22SetAddInfo ( EIB7_AXIS axis,
                                unsigned long addinfo1,
                                unsigned long addinfo2
                                )
```

Parameters

axis AXIS handle
addinfo1 EnDat 2.2 additional datum 1

Addinfo1	Value
EIB7_AI1_NOP	0x00
EIB7_AI1_Diagnostic	0x01
EIB7_AI1_Position2_word1	0x02
EIB7_AI1_Position2_word2	0x03
EIB7_AI1_Position2_word3	0x04
EIB7_AI1_MemoryLSB	0x05
EIB7_AI1_MemoryMSB	0x06
EIB7_AI1_MRS	0x07
EIB7_AI1_TestCommand	0x08
EIB7_AI1_TestValue_word1	0x09
EIB7_AI1_TestValue_word2	0x0A
EIB7_AI1_TestValue_word3	0x0B
EIB7_AI1_Temperature1	0x0C
EIB7_AI1_Temperature2	0x0D
EIB7_AI1_AddSensor	0x0E
EIB7_AI1_Stop	0x0F

addinfo2 EnDat 2.2 additional datum 2

Addinfo2	Value
EIB7_AI2_NOP	0x10
EIB7_AI2_Commutation	0x11
EIB7_AI2_Acceleration	0x12
EIB7_AI2_CommAndAccel	0x13
EIB7_AI2_LimitSignal	0x14
EIB7_AI2_LimitAndAccel	0x15
EIB7_AI2_AsyncPos_word1	0x16
EIB7_AI2_AsyncPos_word2	0x17
EIB7_AI2_AsyncPos_word3	0x18
EIB7_AI2_OPSErrorSource	0x19
EIB7_AI2_ReservedA	0x1A
EIB7_AI2_ReservedB	0x1B
EIB7_AI2_ReservedC	0x1C
EIB7_AI2_ReservedD	0x1D
EIB7_AI2_ReservedE	0x1E
EIB7_AI2_Stop	0x1F

Return code

The return code delivers a status for the function call. In addition to the standard return codes, the following error messages can occur.

EIB7_ParamInvalid	Parameter invalid
EIB7_InvInterface	Axis is not configured for EnDat encoders
EIB7_NotInitialized	Axis is not initialized
EIB7_EnDat22NotSupp	The encoder does not support EnDat 2.2 commands or the axis is not configured for EnDat 2.2 mode

8.31 EnDat 2.2: Selecting the Sequence for Additional Datum

The additional data for an EnDat 2.2 encoder can be configured. The configuration must be in the Polling mode. The additional data is transmitted in the Soft Real-Time, Streaming, and Recording modes.

The sequence of additional data is relayed with each trigger, and after the last entry it begins again with the first entry. The sequence can comprise no more than 10 entries. Additional data 1 and 2 can be selected.

Function

```
EIB7_ERR EIB7EnDat22SetAddInfoCycle ( EIB7_AXIS      axis,
                                       EIB7_MODE      mode,
                                       unsigned char*  data,
                                       unsigned long   len
                                       )
```

Parameters

axis AXIS handle
mode Activate or deactivate FIFO

mode	Description
EIB7_MD_Disable	Deactivate FIFO for additional datum
EIB7_MD_Enable	Activate FIFO for additional datum

data Pointer to an array with the configuration data. Every byte contains an additional datum 1 or 2.

Array element	Value
EIB7_AI1_NOP	0x00
EIB7_AI1_Diagnostic	0x01
EIB7_AI1_Position2_word1	0x02
EIB7_AI1_Position2_word2	0x03
EIB7_AI1_Position2_word3	0x04
EIB7_AI1_MemoryLSB	0x05
EIB7_AI1_MemoryMSB	0x06
EIB7_AI1_MRS	0x07
EIB7_AI1_TestCommand	0x08
EIB7_AI1_TestValue_word1	0x09
EIB7_AI1_TestValue_word2	0x0A
EIB7_AI1_TestValue_word3	0x0B
EIB7_AI1_Temperature1	0x0C
EIB7_AI1_Temperature2	0x0D
EIB7_AI1_AddSensor	0x0E
EIB7_AI1_Stop	0x0F
EIB7_AI2_NOP	0x10
EIB7_AI2_Commutation	0x11
EIB7_AI2_Acceleration	0x12
EIB7_AI2_CommAndAccel	0x13
EIB7_AI2_LimitSignal	0x14
EIB7_AI2_LimitAndAccel	0x15
EIB7_AI2_AsyncPos_word1	0x16
EIB7_AI2_AsyncPos_word2	0x17
EIB7_AI2_AsyncPos_word3	0x18
EIB7_AI2_OPSErrorSource	0x19
EIB7_AI2_ReservedA	0x1A
EIB7_AI2_ReservedB	0x1B
EIB7_AI2_ReservedC	0x1C
EIB7_AI2_ReservedD	0x1D
EIB7_AI2_ReservedE	0x1E
EIB7_AI2_Stop	0x1F

len Size of the array in bytes (≤ 9)

Return code

The return code delivers a status for the function call. In addition to the standard return codes, the following error messages can occur.

EIB7_ParamInvalid Parameter invalid
EIB7_InvInterface Axis is not configured for EnDat encoders
EIB7_NotInitialized Axis is not initialized
EIB7_EnDat22NotSupp The encoder does not support EnDat 2.2 commands or the axis is not configured for EnDat 2.2 mode

8.32 Reading Absolute and Incremental Position Values Simultaneously

The position of an EnDat encoder is read. An EnDat command is sent to the encoder for this purpose. At the same time, the position value is generated from the incremental signals. The two position values are returned together with the status words. This function can only be performed in Polling mode. The axis must be configured for EnDat01 encoders.

Function

```
EIB7_ERR EIB7ReadEnDatIncrPos ( EIB7_AXIS axis,
                                unsigned short* statusEnDat,
                                ENCODER_POSITION* posEnDat,
                                unsigned short* statusIncr,
                                ENCODER_POSITION* posIncr
                                )
```

Parameters

axis	AXIS handle
statusEnDat	<i>[return code]</i> Pointer to the variable for the status word of the EnDat position
posEnDat	<i>[return code]</i> Pointer to the variable for the EnDat position value
statusIncr	<i>[return code]</i> Pointer to the variable for the status word of the incremental position
posEnDat	<i>[return code]</i> Pointer to the variable for the incremental position value

Return code

The return code delivers a status for the function call. In addition to the standard return codes, the following error messages can occur.

EIB7_InvInterface	Axis is not configured for EnDat encoders
EIB7_NotInitialized	Axis is not initialized
EIB7_EncPwrSuppErr	Error in the encoder power supply (encoder is not ready for operation)
EIB7_EnDatErrll	Type II EnDat error occurred
EIB7_EnDatIfBusy	EnDat master not ready for operation
EIB7_EnDatXmitErr	Error during data transmission (encoder might not be connected)
EIB7_CantLatchPos	Position cannot be determined

8.33 Setting the Power Supply for Encoders

The encoder power supply can be activated or deactivated. The "mode" parameter is used to determine whether the power is switched on or off.

Function

```
EIB7_ERR EIB7SetPowerSupply ( EIB7_AXIS axis,
                               EIB7_MODE mode
                               )
```

Parameters

axis	AXIS handle
mode	Activate or deactivate power supply

mode	Description
EIB7_MD_Disable	Switch off power supply
EIB7_MD_Enable	Switch on power supply

Return code

The return code delivers a status for the function call. All potential values are listed for the standard return codes.

8.34 Reading the Power Supply Status for Encoders

The power supply status for the encoder can be read. The "power" parameter can be used to determine whether the power supply for this axis is switched on or off. The "err" parameter indicates whether an error has occurred and the power supply has been switched off due to excessive current load.

Function

```
EIB7_ERR EIB7GetPowerSupplyStatus ( EIB7_AXIS      axis,
                                   EIB7_MODE*      power,
                                   EIB7_POWER_FAILURE* err
                                   )
```

Parameters

axis AXIS handle
power [return code] Pointer to the variable for the power supply status

Power	Description
EIB7_MD_Disable	Power supply switched off
EIB7_MD_Enable	Power supply switched on

err [return code] Pointer to the variable for the overcurrent error

Err	Description
EIB7_PF_None	No error
EIB7_PF_Overcurrent	Power supply has been deactivated due to overcurrent

Return code

The return code delivers a status for the function call. All potential values are listed for the standard return codes.

8.35 Configuring the Timestamp

The timestamp can be activated or deactivated for each axis. The period duration is set globally for all axes of an EIB 74x. The timestamp value is copied during the position poll for an axis if this function was activated beforehand.

Function

```
EIB7_ERR EIB7SetTimestamp ( EIB7_AXIS      axis,
                             EIB7_MODE      mode
                             )
```

Parameters

axis AXIS handle
mode Activate or deactivate timestamp

mode	Description
EIB7_MD_Disable	Deactivate timestamp
EIB7_MD_Enable	Activate timestamp

Return code

The return code delivers a status for the function call. All potential values are listed for the standard return codes.

9 IO Functions

The IO functions always refer only to an individual output or input port on the EIB 74x. None of the other ports is affected.

All IO functions can provide the following error messages as a return code. They can also return further values individually. These are listed separately for each function.

Standard return codes

EIB7_NoError	Function call successful
EIB7_InvalidHandle	The handle to the axis of the EIB 74x is invalid
EIB7_FuncNotSupp	Function is not supported by the EIB 74x
EIB7_InvalidResponse	Error during data transmission
EIB7_AccNotAllowed	Function cannot be performed, as the EIB 74x does not permit access
EIB7_ConnReset	Connection terminated by the EIB 74x
EIB7_ConnTimeout	Timeout during data transmission to the EIB 74x
EIB7_ReceiveError	Error while receiving the data
EIB7_SendError	Error while sending the data
EIB7_OutOfMemory	The system is unable to allocate sufficient memory
EIB7_PortDirInv	Signal direction of the port is incorrect

9.1 Configuring the Input Port

The mode for an input port can be configured using this function. The port can be used as a trigger input or a logical input. The terminating resistor of the differential input can also be activated or deactivated. This function is only permitted in conjunction with handles to input ports.

Function

```
EIB7_ERR EIB7InitInput      (  EIB7_IO           io,
                               EIB7_IOMODE        mode,
                               EIB7_MODE          termination
                               )
```

Parameters

io	IO handle
mode	Trigger input or logical input port

mode	Description
EIB7_IOM_Trigger	Trigger input
EIB7_IOM_Logical	Logical input

termination	Activate or deactivate the terminating resistor
-------------	---

Termination	Description
EIB7_MD_Disable	Deactivate the terminating resistor
EIB7_MD_Enable	Activate the terminating resistor

Return code

The return code delivers a status for the function call. In addition to the standard return codes, the following error messages can occur.

EIB7_ParamInvalid	Parameter invalid
-------------------	-------------------

9.2 Configuring the Output Port

The mode for an output port can be configured using this function. The port can be used as a trigger output or a logical output. Also, the output driver can be deactivated. In this case, the output is in a high-impedance state. This function is only permitted in conjunction with handles to output ports.

Function

```
EIB7_ERR EIB7InitOutput      ( EIB7_IO          io,
                             EIB7_IOMODE       mode,
                             EIB7_MODE        enable
                             )
```

Parameters

io IO handle
mode Trigger output or logical output port

mode	Description
EIB7_IOM_Trigger	Trigger output
EIB7_IOM_Logical	Logical output

enable Activate or deactivate output driver

enable	Description
EIB7_MD_Disable	Deactivate output driver
EIB7_MD_Enable	Activate output driver

Return code

The return code delivers a status for the function call. In addition to the standard return codes, the following error messages can occur.

EIB7_ParamInvalid Parameter invalid

9.3 Selecting the Trigger Source for the Trigger Output

The trigger signal for the trigger output can be selected from different sources. This setting is possible only in the Polling mode and can only be used for trigger outputs.

Function

```
EIB7_ERR EIB7OutputTriggerSource ( EIB7_IO          io,
                                   EIB7_OutputTriggerSrc  src
                                   )
```

Parameters

io IO handle
src Trigger source

src	Description
EIB7_OT_TrInSync	Trigger input synchronized
EIB7_OT_TrInAsync	Trigger input not synchronized
EIB7_OT_TrSW1	Software trigger channel 1
EIB7_OT_TrSW2	Software trigger channel 2
EIB7_OT_TrSW3	Software trigger channel 3
EIB7_OT_TrSW4	Software trigger channel 4
EIB7_OT_TrRImaskedCH1	Gated reference pulse of axis 1 (A&B&RI)
EIB7_OT_TrIC	Interval counter
EIB7_OT_TrPuls	Pulse-counter trigger
EIB7_OT_TrTimer	Timer trigger

Return code

The return code delivers a status for the function call. In addition to the standard return codes, the following error messages can occur.

EIB7_ParamInvalid Parameter invalid

9.4 Setting the Delay Time for the Trigger Input

The time by which a trigger pulse is to be delayed can be set separately for each trigger input. The delay time must be indicated as integral multiple of the clock-pulse period, where the number of clock-pulse periods per microsecond can be read out (EIB7GetTriggerDelayTicks()). The delay time can be deactivated by setting the respective parameter value to zero. This function only applies for trigger inputs.

Function

```
EIB7_ERR EIB7SetTriggerInputDelay ( EIB7_IO      io,
                                   unsigned long  dly
                                   )
```

Parameters

io IO handle (only for inputs)
dly Delay time in clock cycles (<= 256); also see "Note" in Chapter 4

Return code

The return code delivers a status for the function call. In addition to the standard return codes, the following error messages can occur.

EIB7_ParamInvalid Parameter invalid

9.5 Reading Out a Logical Port

The level at a logical input or output is read ("level" parameter). The operating mode of the port is also determined. If the port is operated as a trigger input or trigger output, the value of "level" is invalid. For a logical output, the set level is read back.

Function

```
EIB7_ERR EIB7ReadIO ( EIB7_IO      io,
                      EIB7_IOMODE* mode,
                      unsigned long* level
                      )
```

Parameters

io IO handle
mode *[return code]* Pointer to the variable for the operating mode

mode	Description
EIB7_IOM_Trigger	Trigger port
EIB7_IOM_Logical	Logical port

level *[return code]* Pointer to the variable for the logical level of the port

Level	Description
0	low level
1	high level

Return code

The return code delivers a status for the function call. In addition to the standard return codes, the following error messages can occur.

EIB7_ParamInvalid Parameter invalid

9.6 Setting the Logical Output Port

The level of a logical output port is set. The "level" parameter indicates whether the output is set to high or low. This function can only be applied to outputs that have been configured for logic mode. If the port is used as a trigger output, the function generates an error message.

Function

```
EIB7_ERR EIB7WriteIO      ( EIB7_IO      io,
                           unsigned long  level
                           )
```

Parameters

io IO handle
level Logical level of the output

Level	Description
0	low level
1	high level

Return code

The return code delivers a status for the function call. In addition to the standard return codes, the following error messages can occur.

EIB7_ParamInvalid Parameter invalid
EIB7_TrgNotConf Output is not a logical port

9.7 Reading the Configuration Data for an Input

The configuration data for an input port is read. The "mode" parameter supplies the operating mode of the input. In "termination," the status of the terminating resistor is returned. The function may only be used for input ports.

Function

```
EIB7_ERR EIB7GetInputConfig ( EIB7_IO      io,
                              EIB7_IOMODE*   mode,
                              EIB7_MODE*     termination
                              )
```

Parameters

io IO handle
mode [*return code*] Pointer to the variable for the operating mode

mode	Description
EIB7_IOM_Trigger	Trigger input
EIB7_IOM_Logical	Logical input

termination [*return code*] Pointer to the variable for the terminating resistor

Termination	Description
EIB7_MD_Disable	Terminating resistor deactivated
EIB7_MD_Enable	Terminating resistor activated

Return code

The return code delivers a status for the function call. In addition to the standard return codes, the following error messages can occur.

EIB7_ParamInvalid Parameter invalid

9.8 Reading the Configuration Data for an Output

The configuration data for an output port is read. The "mode" parameter supplies the operating mode of the output. In "enable," the status of the output driver is returned. The function may only be used for output ports.

Function

```
EIB7_ERR EIB7GetOutputConfig ( EIB7_IO          io,
                               EIB7_IOMODE*      mode,
                               EIB7_MODE*        enable
                             )
```

Parameters

io IO handle
mode *[return code]* Pointer to the variable for the operating mode

mode	Description
EIB7_IOM_Trigger	Trigger output
EIB7_IOM_Logical	Logical output

enable *[return code]* Pointer to the variable for the status of the output driver

enable	Description
EIB7_MD_Disable	Output driver deactivated
EIB7_MD_Enable	Output driver activated

Return code

The return code delivers a status for the function call. In addition to the standard return codes, the following error messages can occur.

EIB7_ParamInvalid Parameter invalid

10 General Functions

All general functions can supply the following error messages as a return code. They can also return further values individually. These are listed separately for each function.

Standard return codes

EIB7_NoError	Function call successful
EIB7_OutOfMemory	The system is unable to allocate sufficient memory

10.1 Reading the Driver ID Number

The product number (ID) of the driver is generated as a C string. The string is saved to the "ident" pointer. The size of the memory for the string must be indicated in bytes via the "len" parameter. If the string, including the final null byte, is longer than the memory area, an error message will be generated. The target memory must be at least 9 bytes.

Function

```
EIB7_ERR EIB7GetDriverID      ( char*          ident,  
                               unsigned long    len  
                               )
```

Parameters

ident	<i>[return code]</i> Target memory for the C string
len	Size of the target memory in bytes

Return code

The return code delivers a status for the function call. In addition to the standard return codes, the following error messages can occur.

EIB7_BufferTooSmall	Target memory is too small
---------------------	----------------------------

10.2 Converting an Error Message into Text

An error code is converted into a text message and returned as a C string. A descriptive text and a brief description are defined in the system for all known error codes. The "mnemonic" parameter is used to return a brief description of the error message in text format (approx. 30-40 characters). The "message" parameter contains a more detailed description (approx. 100-150 characters). If a NULL pointer is transferred for either the "mnemonic" or "message" parameter, the function does not copy the corresponding text. If the target memory is too small to take the entire text, only the first part is copied. The string always ends with a null byte.

Function

```
EIB7_ERR EIB7GetErrorInfo    ( EIB7_ERR      code,  
                               char*          mnemonic,  
                               unsigned long   mnemlen,  
                               char*          message,  
                               unsigned long   msglen  
                               )
```

Parameters

code	Error code that is converted into text
mnemonic	<i>[return code]</i> Pointer to the target memory for the brief description
mnemlen	Size of the "mnemonic" target memory in bytes
message	<i>[return code]</i> Pointer to the target memory for the error text
msglen	Size of the "message" target memory in bytes

Return code

The return code delivers a status for the function call. In addition to the standard return codes, the following error messages can occur.

EIB7_IllegalParameter	Invalid error code
-----------------------	--------------------

HEIDENHAIN

DR. JOHANNES HEIDENHAIN GmbH

Dr.-Johannes-Heidenhain-Straße 5

83301 Traunreut, Germany

☎ +49 8669 31-0

☎ +49 8669 5061

E-mail: info@heidenhain.de

Technical support ☎ +49 8669 32-1000

Measuring systems ☎ +49 8669 31-3104

E-mail: service.ms-support@heidenhain.de

TNC support ☎ +49 8669 31-3101

E-mail: service.nc-support@heidenhain.de

NC programming ☎ +49 8669 31-3103

E-mail: service.nc-pgm@heidenhain.de

PLC programming ☎ +49 8669 31-3102

E-mail: service.plc@heidenhain.de

Lathe controls ☎ +49 8669 31-3105

E-mail: service.lathe-support@heidenhain.de

www.heidenhain.de

SALES & SERVICE:

A Tech Authority, Inc.

13745 Stockton Ave.

Chino CA 91710

909-614-4522

sales@atechauthority.com