

Order separately:  
Separat bestellen:  
A commander séparément:  
Ordinare a parte:  
Para pedir por separado:

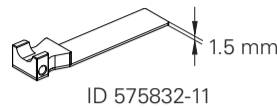

# HEIDENHAIN

**SALES & SERVICE:**  
**A Tech Authority, Inc.**  
13745 Stockton Ave.  
Chino CA 91710  
909-614-4522  
sales@atechauthority.com

## LC 1x6

Absolute linear encoder  
Absolutes Längenmessgerät  
Système de mesure linéaire absolu  
Sistema di misura assoluto  
Sistema lineal de medida absoluto



02/2022

1356278 · Ver00 · 01 · Printed in Germany

**General Information · Allgemeine Hinweise · Informations générales · Informazioni generali · Información general**

**!** **Note:** Mounting and commissioning is to be conducted by a qualified specialist under compliance with local safety regulations. Do not engage or disengage any connections while under power. The system must be disconnected from power.

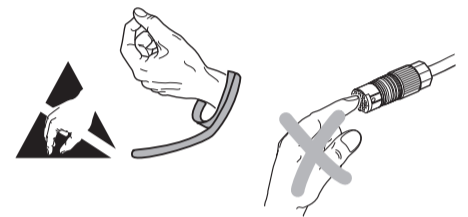

Dimensions in mm  
Maße in mm  
Cotes en mm  
Dimensioni in mm  
Dimensiones en mm

**Achtung:** Die Montage und Inbetriebnahme ist von einer qualifizierten Fachkraft unter Beachtung der örtlichen Sicherheitsvorschriften vorzunehmen.

Die Steckverbindung darf nur spannungsfrei verbunden oder gelöst werden. Die Anlage muss spannungsfrei geschaltet sein!

**Attention:** Le montage et la mise en service doivent être assurés par un personnel qualifié dans le respect des consignes de sécurité locales.

Le connecteur ne doit être connecté ou déconnecté qu'hors potentiel. L'équipement doit être connecté hors potentiel!

**Attenzione:** Il montaggio e la messa in funzione devono essere eseguite da personale qualificato nel rispetto delle norme di sicurezza locali.

I cavi posso essere collegati o scollegati solo in assenza di tensione. L'impianto deve essere spento!

**Atención:** El montaje y la puesta en marcha deben ser realizados por un especialista cualificado, observando las prescripciones locales de seguridad.

Conectar o desconectar el conector sólo en ausencia de tensión. ¡La instalación debe ser conectada en ausencia de tensión!

**General Information · Allgemeine Hinweise · Informations générales · Informazioni generali · Información general**

Mounting surface clean and free of paint  
Anbaufläche sauber und lackfrei  
Surface de montage propre et exempte de peinture  
Superficie di montaggio pulita e non verniciata  
Superficie de montaje limpia y libre de barniz

ML = Measuring length  
Messlänge  
Longueur de mesure  
Corsa utile  
Longitud de medición

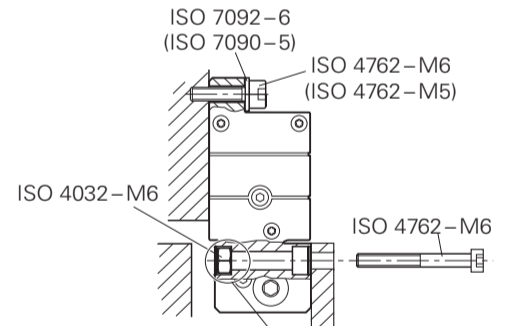
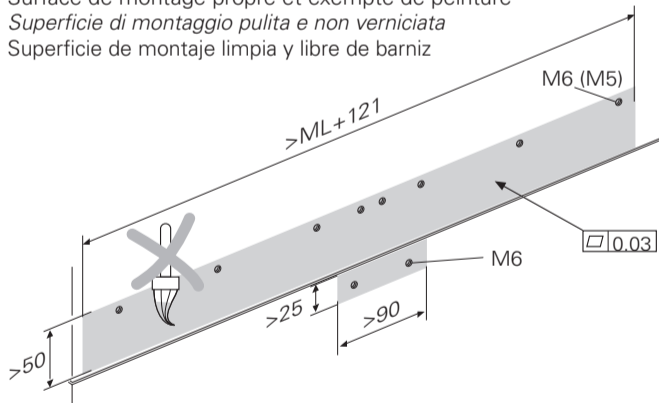

Engage the M6 nut  
Mutter M6 einrasten  
Engager l'écrou M6  
Inserire il dado M6  
Engranar la tuerca M6

**General Information · Allgemeine Hinweise · Informations générales · Informazioni generali · Información general**

Cable connection usable at either end  
Kabelanschluss beidseitig verwendbar  
Raccordement du câble possible des deux côtés  
Il cavo può essere connesso ai due lati della testina  
Conexión de cable utilizable por ambos lados

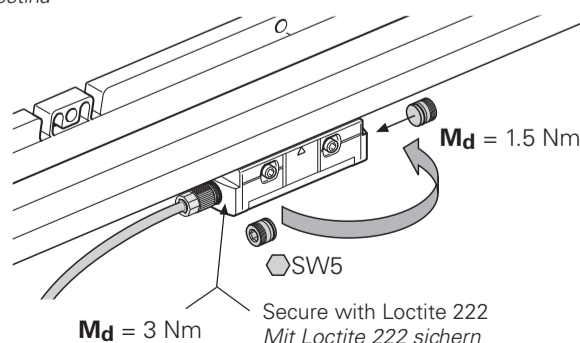

Secure with Loctite 222  
Mit Loctite 222 sichern  
Consolider avec Loctite 222  
Fissare con Loctite 222  
Fijar con Loctite 222

Loosen by 1/4 revolution for movement  
Zum Bewegen 1/4 Umdrehung lösen  
Dévisser de 1/4 de tour pour déplacement  
Allentare di 1/4 di giro  
Aflojar 1/4 de vuelta

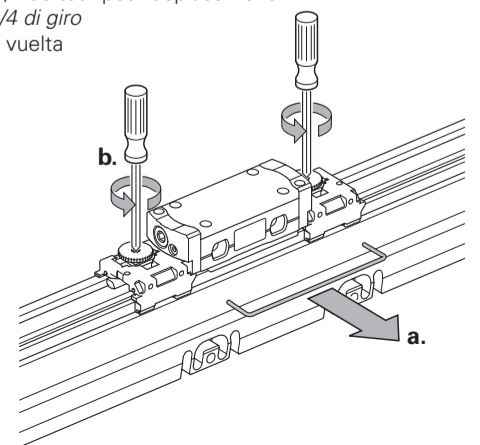

Assembly · Montage · Montage · Montaggio · Montaje

F = Machine guideway  
 Maschinenführung  
 Guidage de la machine  
 Guida della macchina  
 Guía de la máquina

Ⓢ = Begin. of meas. length ML  
 Beginn der Messlänge ML  
 Début longueur utile ML  
 Inizio lunghezza di misura ML  
 Comienzo longitud útil ML

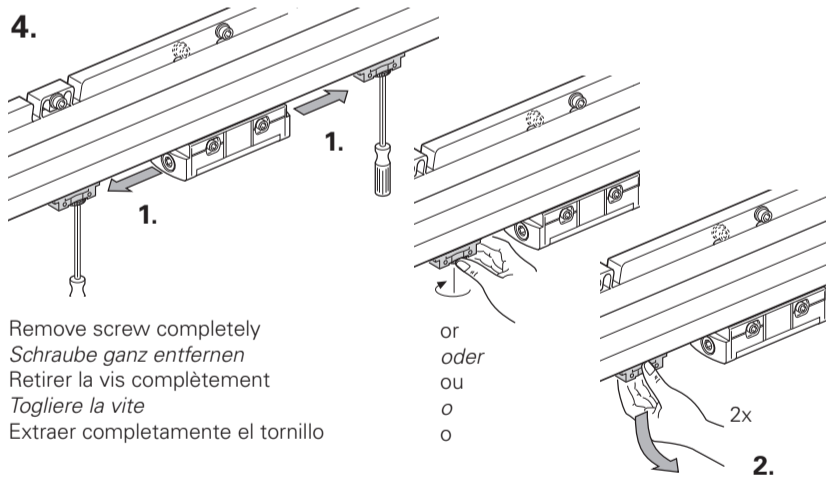
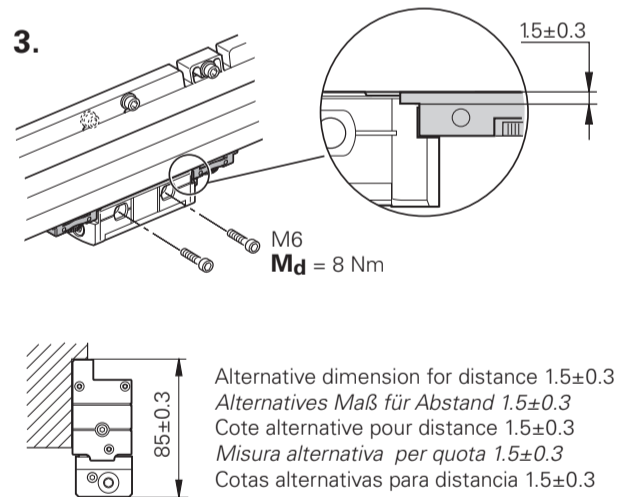
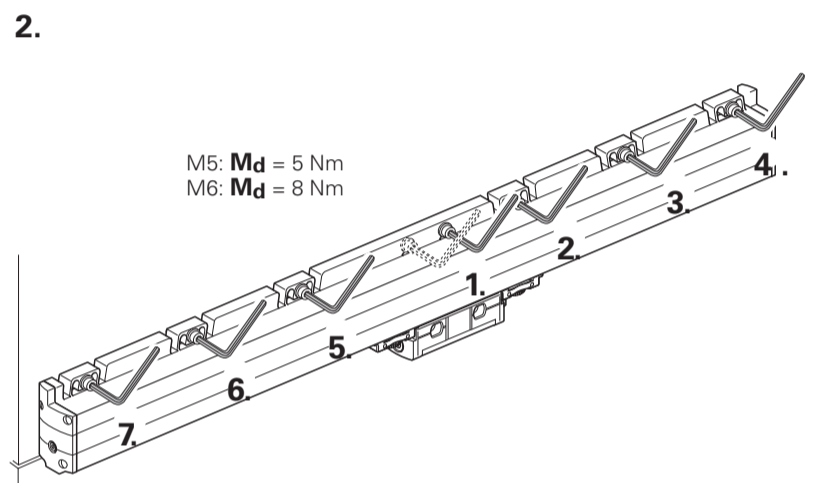
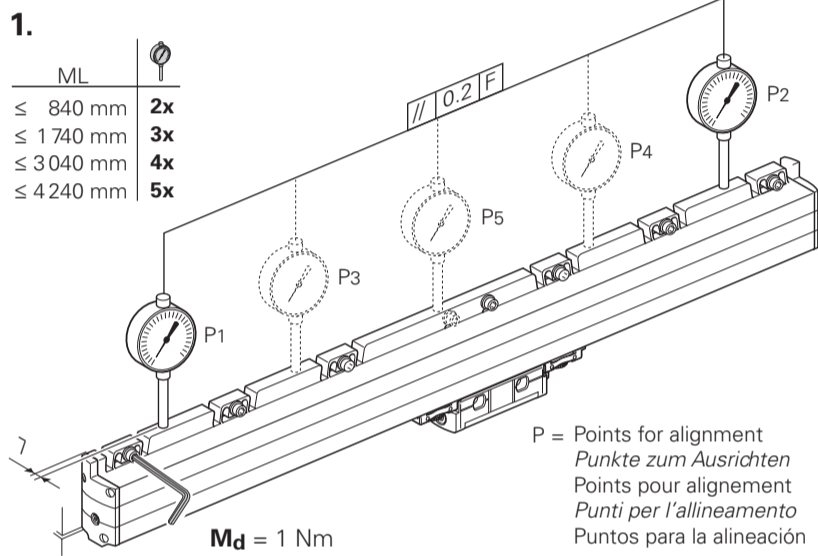
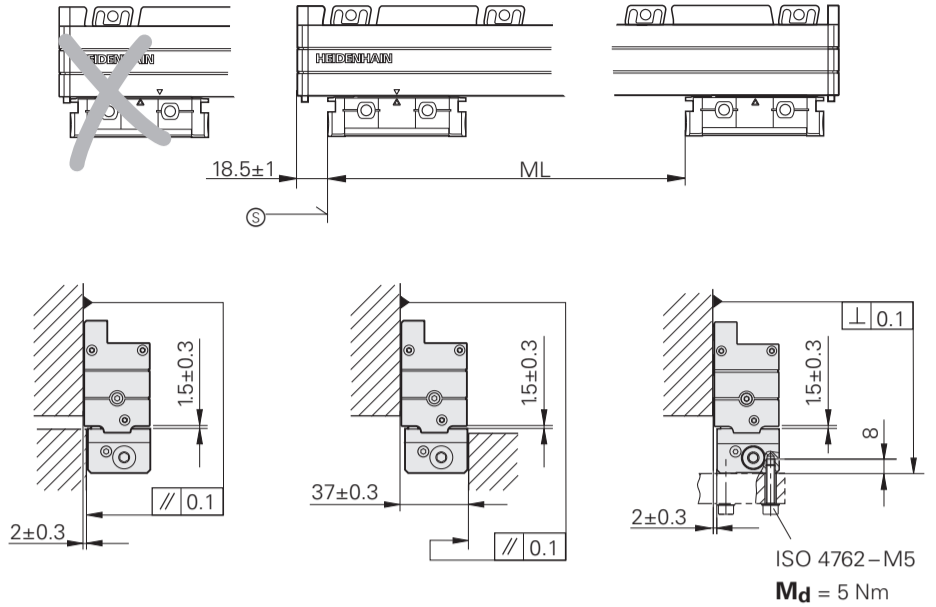
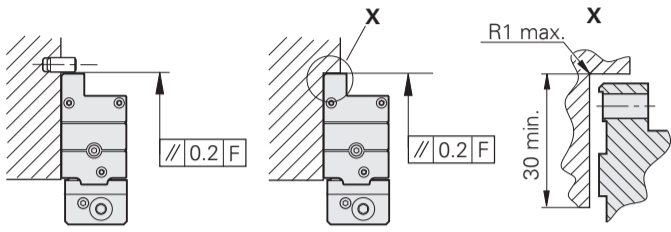

Final Steps · Abschließende Arbeiten · Opérations finales · Operazioni finali · Trabajos finales

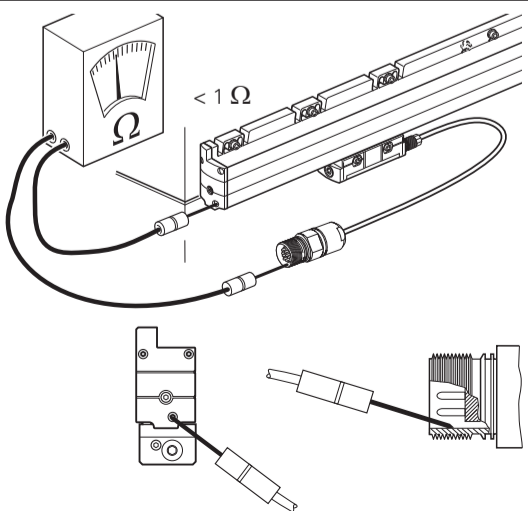

optional · optional · option · opzionali · opcional

Ⓢ = Compressed-air connection usable at either end  
 Druckluftanschluss beidseitig möglich  
 Raccordement d'air comprimé possible des deux côtés  
 Connessioni per aria compressa sui due lati  
 Toma de aire comprimido posible por ambos lados

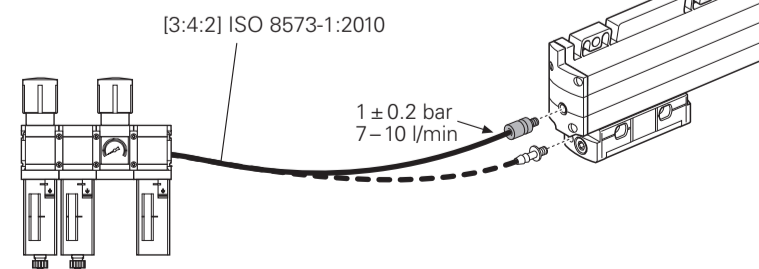

Vertical mounting  
 Senkrechter Anbau  
 Montage vertical  
 Montaggio verticale  
 Montaje vertical

