

LP2 modular probe system for tool setting and workpiece inspection

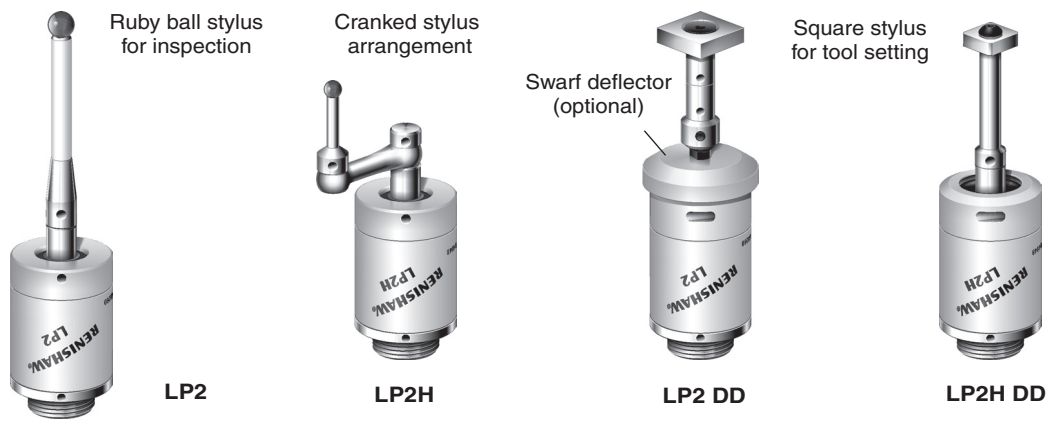

Ruby ball stylus for inspection
LP2

Cranked stylus arrangement
LP2H

Swarf deflector (optional)
LP2 DD

Square stylus for tool setting
LP2H DD

LP2 compact probes are sealed for use within the machine's hostile environment of coolant and hot metal chips.

H versions have a higher spring force, which allows use of longer styli, and greater resistance to machine vibration.

DD versions are specified for applications subject to particle laden coolant. The diaphragm material is resistant to coolants and elevated temperatures. However, if the probe is subjected to continual exposure to hot metal chips, use of the swarf deflector is recommended.

LP2 probe systems include a wide range of styli and accessories to provide customised installations

Features

- **Principal application**
Horizontal lathes
Small enough to fit on turret for part measuring, tool setting and broken tool detection when mounted in a suitable position.
Machining centre applications
Set-up and part measuring when spindle mounted. Tool setting and broken tool detection when table mounted.
- **Compact and robust**
Ø25 x 40.8 mm long (Ø0.98 x 1.6 in long).
- **Probe sealing**
Sealed to IPX8.
- **Repeatability**
Inherent repeatability with all stylus configurations.
- **Modular extensions and adaptors**
provide ready made installation solutions.
- **Stylus weak link protects probe in event of a collision** (optional)
- **Signal transmission systems**
 - Hard wired - for machining centres with manual tool change. The LP2 is used with the MA2 probe holder.
 - Inductive - for machining centres and lathes, eliminates the need for probe batteries.
 - Optical - for lathes.
Easy installation, particularly in retrofit applications as there is no need for prepared passageways required for inductive transmission cables. The LP2 fits onto LTO2/LTO2S/LTO2T/LTO3T optical modules.
- **Software for probe routines**
Renishaw supplies an extensive suite of probing routines for the majority of machine controllers.

LP2 dimensions

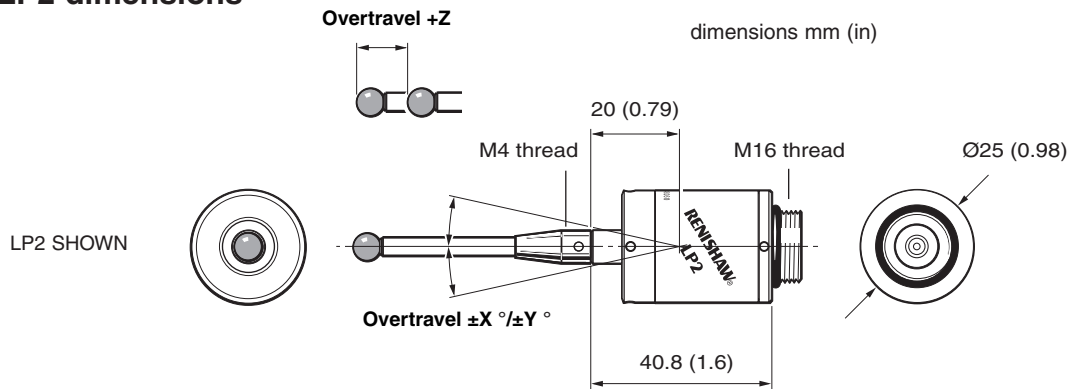

LP2 and LP2 DD specification

Probing directions $\pm X, \pm Y, +Z$

Stylus overtravel

LP2	X and Y direction	$\pm 12.5^\circ$
	Z direction	6.5 mm (0.25 in)
LP2 DD	X and Y direction	$\pm 15^\circ$
	Z direction	6.5 mm (0.25 in)
	Z when fitted with swarf deflector	4.5 mm (0.18 in)

Uni-directional repeatability with 35 mm (1.37 in) stylus

1.0 μm (0.00004 in) valid for test velocity of 480 mm/min (1.5 ft/min) at stylus tip

Trigger force adjustable - factory setting given

XY plane - lowest force	0.5 N (50 gf) 1.76 ozf
XY plane - highest force	0.9 N (90 gf) 3.17 ozf
+Z direction	5.85 N (585 gf) 20.6 ozf

Weight 65g (2.3 oz)

Stylus length
Standard 50 mm (1.97 in)
Longest 100 mm (3.94 in)

Mounting M16 thread, for LT extension bars and adaptors

Interface for transmission system

Hard wired	MI 5 or MI 8 or MI 8-4
Inductive	MI 5
Optical	MI 12 + OMM or OMI

LP2H and LP2H DD specification

Probing directions $\pm X, \pm Y, +Z$

Stylus overtravel

LP2H	X and Y direction	$\pm 12.5^\circ$
	Z direction	5.0 mm (0.25 in)
LP2H DD	X and Y direction	$\pm 15^\circ$
	Z direction	5.0 mm (0.20 in)
	Z when fitted with swarf deflector	4.5 mm (0.18 in)

Uni-directional repeatability with 35 mm (1.37 in) stylus

2.0 μm (0.00008 in) valid for test velocity of 480 mm/min (1.5 ft/min) at stylus tip

Trigger force NOT adjustable

XY plane - lowest force	2.0 N (200 gf) 1.76 ozf
XY plane - highest force	4.0 N (400 gf) 14.10 ozf
+Z direction	30 N (3.0 kgf) 6.6 lbf

Weight 65g (2.3 oz)

Stylus length
Standard 50 mm (1.97 in)
Longest 150 mm (5.51 in)

Mounting M16 thread, for LT extension bars and adaptors

Interface for transmission system

Hard wired	MI 5 or MI 8 or MI 8-4
Inductive	MI 5
Optical	MI 12 + OMM or OMI

Probe sealing

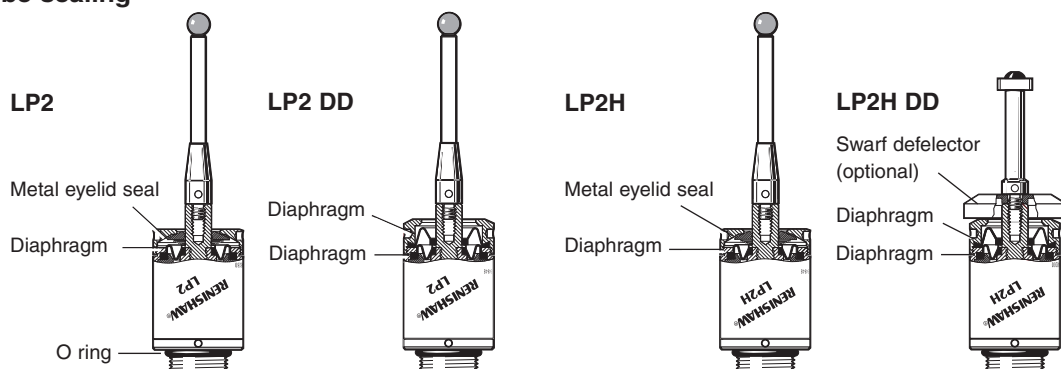

LP2 system

Representative examples of the LP2 modular system are shown below. More comprehensive information is provided on the Data sheets listed on the next page. Please consult your local supplier for installation advice.

MAINTENANCE

The probe system requires only minimum maintenance. Periodically clean the probe's front seal and check the security of wiring.

STYLUS ALIGNMENT

Workpiece inspection

Adaptors and holders incorporate adjusters to enable the stylus to be aligned with the spindle centre line.

Tool setting

Square tip styli can be adjusted to align with the machine's X/Y axes. Further fine rotational adjustment is provided with probe socket FS1.

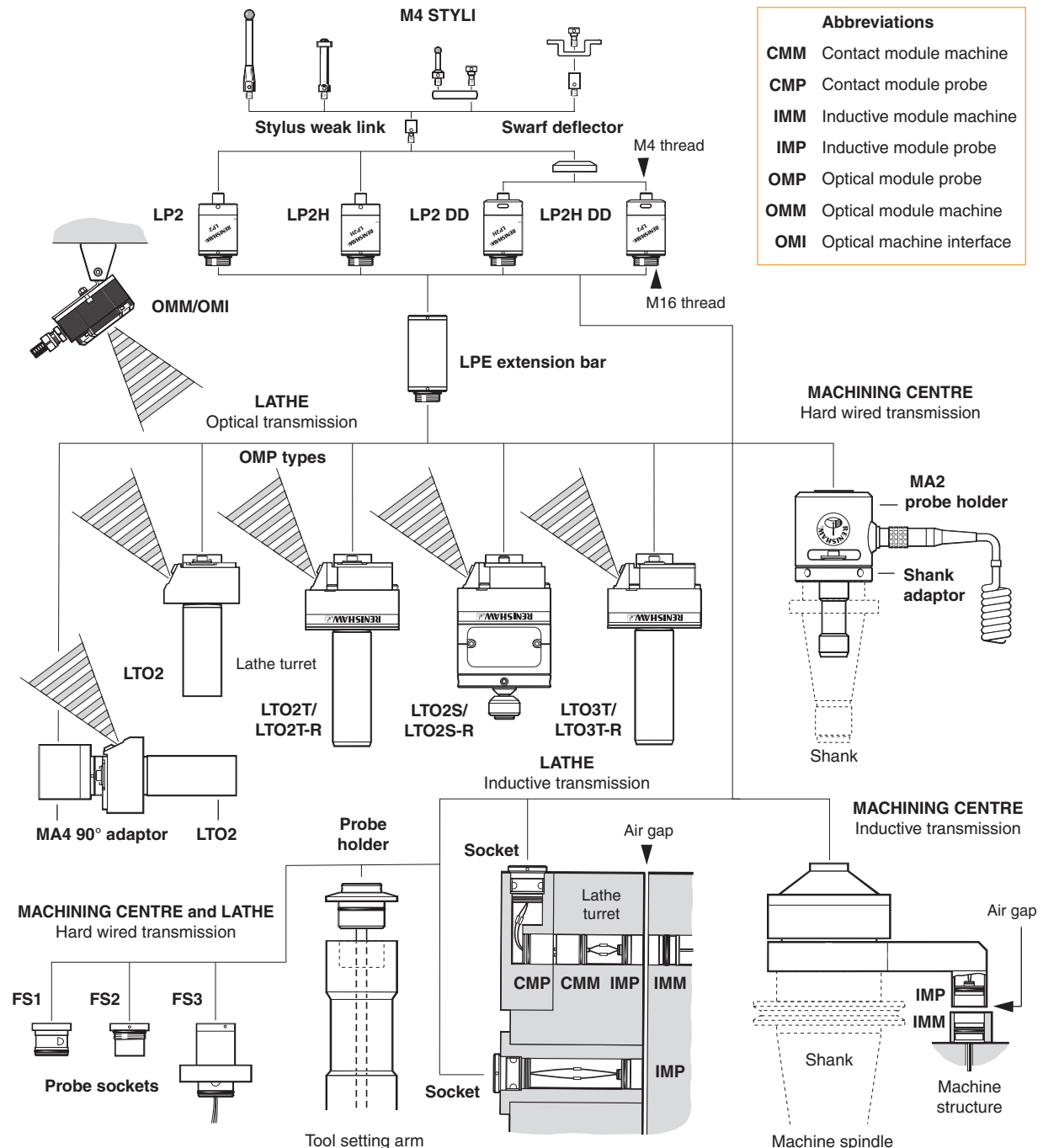

Parts list - Please quote the Part no. when ordering equipment.

Type	Part no.	Description
LP2	A-2063-6098	LP2 probe supplied with two C spanners and TK1 tool kit.
LP2H	A-2064-0002	LP2H probe supplied with two C spanners and TK1 tool kit.
LP2 DD	A-2063-8020	LP2 DD probe supplied with two C spanners and TK1 tool kit.
LP2H DD	A-2064-0032	LP2H DD probe supplied with two C spanners and TK1 tool kit.
TK1	A-2053-7531	Probe tool kit comprising: Ø1.98 mm stylus tool, 1.5 mm AF hexagon key, 2.0 mm AF hexagon key, 2.5 mm AF hexagon key, 3.0 mm AF hexagon key and 4.0 mm AF hexagon key.
C spanner	A-2063-7587	C spanner: One required for fitting probe to machine. Two required to connect probe to extension bar or removing front cap for cleaning.
DK2 kit	A-2063-7542	Service kit for LP2 and LP2H comprising: Front cap, metal eyelid, spring and rear O ring.
DDCK kit	A-2063-8023	Diaphragm conversion kit: Converts LP2 to LP2DD or LP2H to LP2H DD comprising: Two C spanners, front ring, outer diaphragm and rear O ring.
DDRK kit	A-2063-8030	Diaphragm replacement kit for LP2 DD and LP2H DD comprising: Outer diaphragm and rear O ring.
SA8	M-5000-7582	Stylus adaptor with break protection.
SD1	M-2063-8003	Swarf deflector.
Styli	—	See Brochure H-1000-3200 Styli and accessories.
Adaptors/extensions holders/socket	—	See Data sheet H-2000-2120 Adaptors, extensions and holders.
Probe holder	—	See Data sheet H-2000-2115 High precision arm with LP2 holder.
Hard wired transmission	—	See Data sheet H-2000-2091 LP2 hard wired transmission.
Inductive transmission	—	See Data sheet H-2000-2140 Inductive transmission system.
MI 5 interface	—	See Data sheet H-2000-2180 MI 5 interface unit.
MI 8 interface	—	See Data sheet H-2000-2191 MI 8 interface unit.
MI 8-4 interface	—	See Data sheet H-2000-2185 MI 8-4 interface unit.
Optical transmission	—	See Data sheet H-2000-2268 LTO2S and LTO2R optical modules.
Optical transmission	—	See Data sheet H-2000-2271 LTO2 optical module.
OMM	—	See Data sheet H-2000-2275 Optical module machine.
OMI	—	See Data sheet H-2000-2285 Optical machine interface.
MI 12 interface	—	See Data sheet H-2000-2195 MI 12 interface unit.
PSU3 power supply	—	See Data sheet H-2000-2200 PSU3 power supply unit.
Software	—	See Data sheet H-2000-2289 Probe software for machine tools
LP2 RK	—	See H-2000-4028 Diaphragm replacement/conversion kit instructions.
DK2	—	See H-2000-4027 DK2 LP2 service kit instructions.

For worldwide contact details, please visit our
main web site at www.renishaw.com/contact



H - 2000 - 2100 - 15