

ID-Encoder

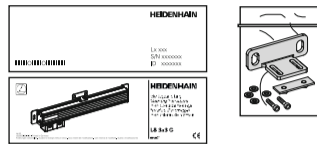

1364538-00-B-01 · Printed in EU

HEIDENHAIN

SALES & SERVICE:

A Tech Authority, Inc.
13745 Stockton Ave.
Chino CA 91710
909-614-4522
sales@atechauthority.com

ns
itaje
gio
ontaje

LS 6x3 (C)

01/2022



Allgemeine Hinweise · General Information · Informations générales · Informazioni generali · Información general



Achtung: Die Montage und Inbetriebnahme ist von einer qualifizierten Fachkraft unter Beachtung der örtlichen Sicherheitsvorschriften vorzunehmen.
Die Steckverbindung darf nur spannungsfrei verbunden oder gelöst werden.
Die Anlage muss spannungsfrei geschaltet sein!

Note: Mounting and commissioning is to be conducted by a qualified specialist under compliance with local safety regulations.
Do not engage or disengage any connections while under power.
The system must be disconnected from power.

Attention: Le montage et la mise en service doivent être assurés par un personnel qualifié dans le respect des consignes de sécurité locales.
Le connecteur ne doit être connecté ou déconnecté qu'hors potentiel.
L'équipement doit être connecté hors potentiel!

Attenzione: Il montaggio e la messa in funzione devono essere eseguite da personale qualificato nel rispetto delle norme di sicurezza locali.
I cavi posso essere collegati o scollegati solo in assenza di tensione.
L'impianto deve essere spento!

Atención: El montaje y la puesta en marcha deben ser realizados por un especialista cualificado, observando las prescripciones locales de seguridad.
Conectar o desconectar el conector sólo en ausencia de tensión.
¡La instalación debe ser conectada en ausencia de tensión!

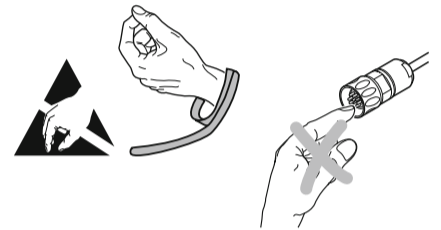

Maße in mm
Dimensions in mm
Cotes en mm
Dimensioni in mm
Dimensiones en mm

Allgemeine Hinweise · General Information · Informations générales · Informazioni generali · Información general

Anbauflächen sauber und lackfrei
Mounting surfaces clean and free of paint
Surfaces de montage propre et exempte de peinture
Superfici di montaggio pulita e non verniciata
Superficies de montaje limpia y libre de barniz

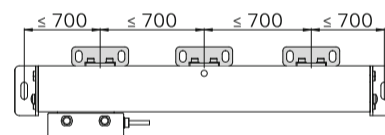
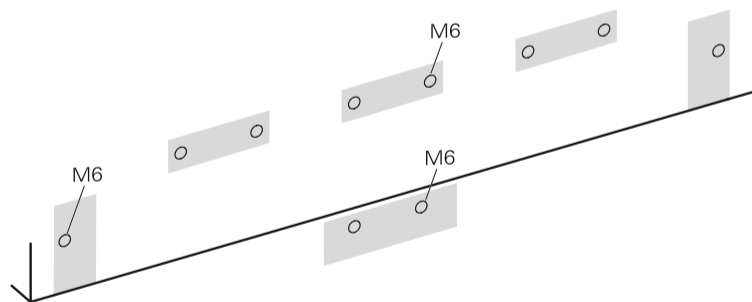

ML ≥ 620	1 x
ML ≥ 1140	2 x
ML ≥ 2040	3 x
ML ≥ 2840	4 x

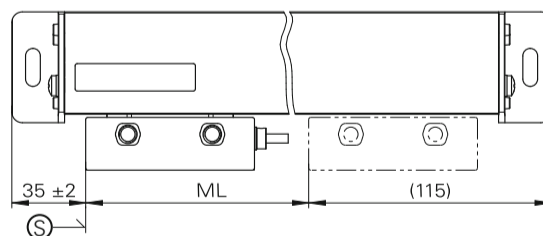

Ⓢ = Beginn der Messlänge ML
Begin. of meas. length ML
Début longueur utile ML
Inizio lunghezza di misura ML
Comienzo longitud útil ML

Allgemeine Hinweise · General Information · Informations générales · Informazioni generali · Información general

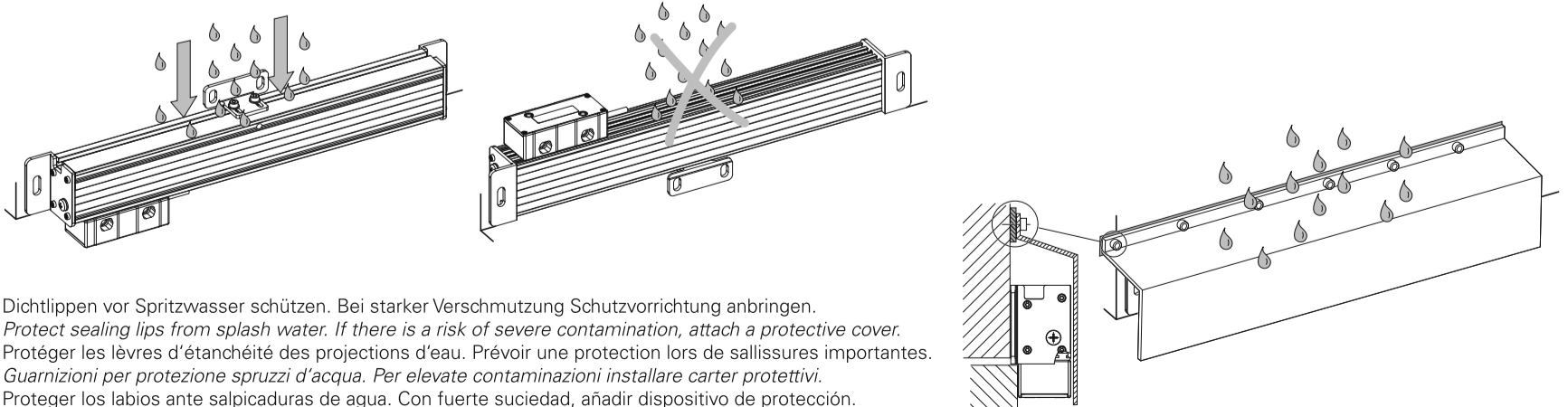

Dichtlippen vor Spritzwasser schützen. Bei starker Verschmutzung Schutzvorrichtung anbringen.
Protect sealing lips from splash water. If there is a risk of severe contamination, attach a protective cover.
Protéger les lèvres d'étanchéité des projections d'eau. Prévoir une protection lors de saillissures importantes.
Guarnizioni per protezione spruzzi d'acqua. Per elevate contaminazioni installare carter protettivi.
Proteger los labios ante salpicaduras de agua. Con fuerte suciedad, añadir dispositivo de protección.

Hinweise zur Montage · Mounting Information · Remarques relatives au montage · Avvertenze per il montaggio · Indicaciones para el montaje

ML ≥ 620 mm

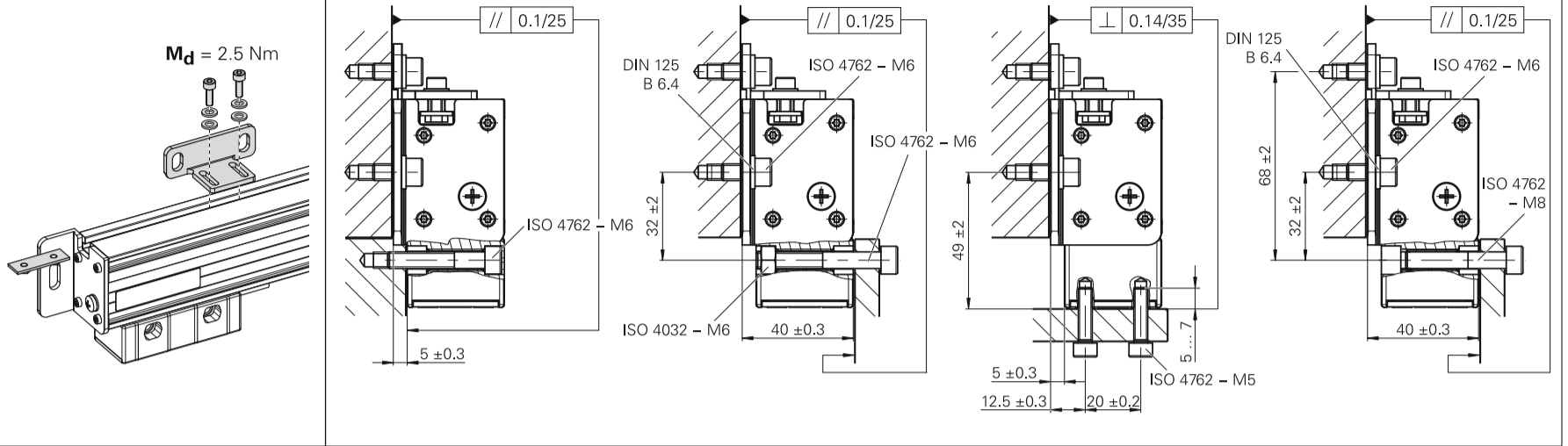

Montage · Assembly · Montage · Montaggio · Montaje

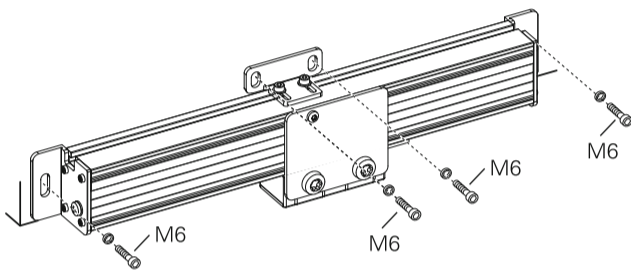

ML < 620 mm

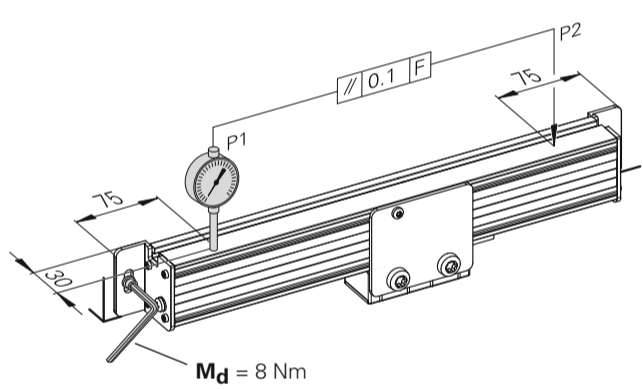

ML ≥ 620 mm

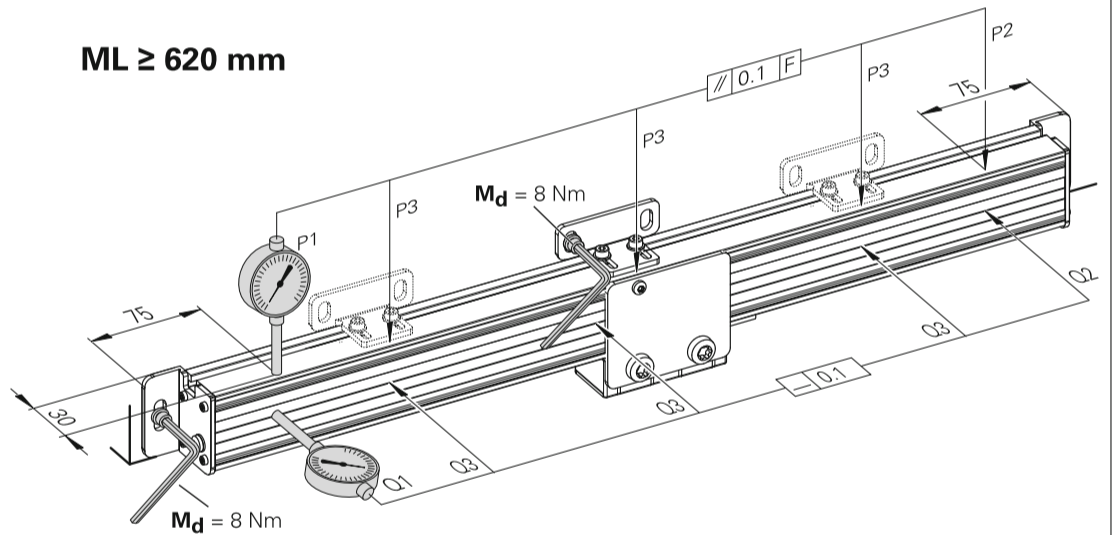

F = Maschinenführung
Machine guideway
Guidage de la machine
Guida della macchina
Guía de la máquina

P, Q = Punkte zum Ausrichten
Points for alignment
Points pour alignement
Punti per l'allineamento
Puntos para la alineación

Transportsicherung entfernen
Remove the shipping brace
Retirer la sécurité de transport
Rimuovere il dispositivo di sicurezza per il trasporto
Retirar el seguro de transporte

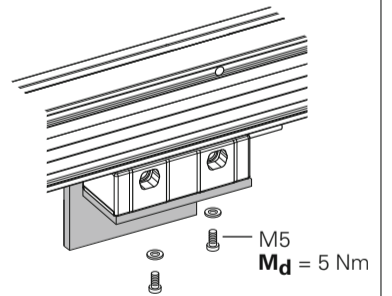
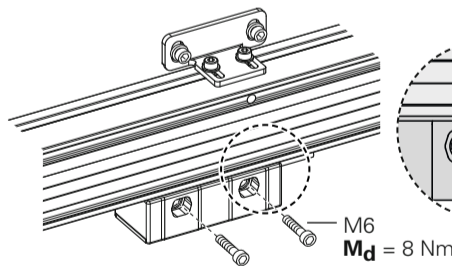
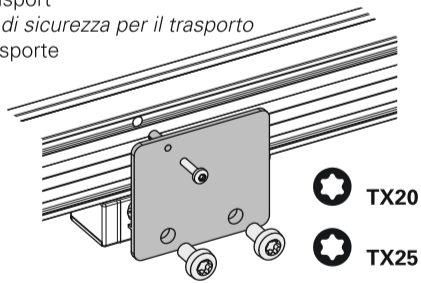

Abschließende Arbeiten · Final Steps · Opérations finales · Operazioni finali · Trabajos finales

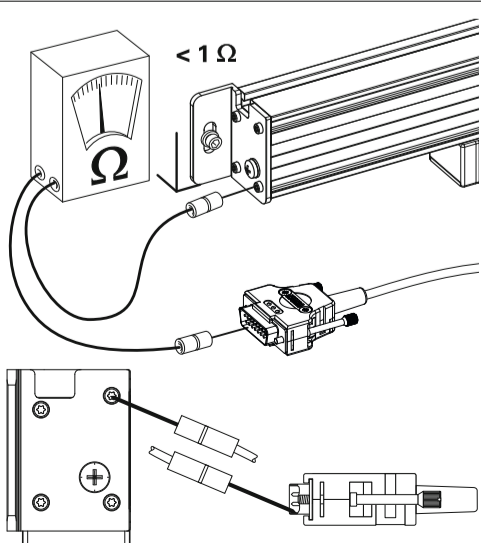

Farbbelegung / Colour Assignment

Signal 1 Vss Signal 1 Vpp	Signal TTL Signal TTL	Farbe Colour
A+	Ua1	Grün/Green
A-	$\bar{U}a1$	Gelb/Yellow
B+	Ua2	Rosa/Pink
B-	$\bar{U}a2$	Rot/Red
R+	Ua0	Braun/Brown
R-	$\bar{U}a0$	Grau/Grey
Belegt/Occupied	Belegt/Occupied	Naturfarb./Nature c.
Belegt/Occupied	$\bar{U}aS$	Blau/Blue
+V	+V	Schwarz/Black
0V	0V	Weiß/White
Schirm/Shield	Schirm/Shield	Schirm/Shield

DA 400

