



SALES & SERVICE:

A Tech Authority, Inc.
13745 Stockton Ave.
Chino CA 91710
909-614-4522
sales@atechauthority.com



ND 7000

Operating Instructions

Digital Readout

Contents

1	Fundamentals.....	15
2	Safety.....	25
3	Transport and Storage.....	31
4	Mounting.....	35
5	Installation.....	41
6	Basic Operation.....	57
7	Commissioning.....	91
8	Setup.....	119
9	Milling – Quick Start.....	151
10	Turning – Quick Start.....	169
11	Milling – Manual operation.....	181
12	Turning – Manual operation.....	189
13	Milling – MDI mode.....	197
14	Turning – MDI mode.....	209
15	File Management.....	217
16	Settings.....	225
17	Service and Maintenance.....	271
18	What to do if	279
19	Removal and Disposal.....	285
20	Specifications.....	287
21	Index.....	296
22	List of Figures.....	298

1	Fundamentals.....	15
1.1	Overview.....	16
1.2	Information on the product.....	16
1.3	Demo software for the product.....	16
1.4	Documentation on the product.....	17
1.4.1	Validity of the documentation.....	17
1.4.2	Notes on reading the documentation.....	18
1.4.3	Storage and distribution of the documentation.....	19
1.5	About these instructions.....	19
1.5.1	Document category.....	19
1.5.2	Target groups for the instructions.....	19
1.5.3	Target groups according to user types.....	20
1.5.4	Contents of the chapters.....	20
1.5.5	Notes in this documentation.....	22
1.5.6	Symbols and fonts used for marking text.....	23
2	Safety.....	25
2.1	Overview.....	26
2.2	General safety precautions.....	26
2.3	Intended use.....	26
2.4	Improper use.....	27
2.5	Personnel qualification.....	27
2.6	Obligations of the operating company.....	28
2.7	General safety precautions.....	28
2.7.1	Symbols on the product.....	28
2.7.2	Electrical safety precautions.....	29

3	Transport and Storage	31
3.1	Overview	32
3.2	Unpacking	32
3.3	Items supplied and accessories	32
3.3.1	Items supplied	32
3.3.2	Accessories	33
3.4	In case of damage in transit	34
3.5	Repackaging and storage	34
3.5.1	Repackaging the product	34
3.5.2	Storage of the product	34
4	Mounting	35
4.1	Overview	36
4.2	Assembly of the product	36
4.2.1	Mounting on Single-Pos stand	37
4.2.2	Mounting on Multi-Pos stand	39
4.2.3	Mounting on Multi-Pos holder	40
5	Installation	41
5.1	Overview	42
5.2	General information	43
5.3	Product overview	44
5.4	Connecting encoders	46
5.5	Connecting touch probes	47
5.6	Wiring switching inputs and outputs	48
5.7	Connecting a printer	53
5.8	Connecting input devices	53
5.9	Connecting a network peripheral	54
5.10	Connecting the line voltage	55

6 Basic Operation.....	57
6.1 Overview.....	58
6.2 Using the touchscreen and input devices.....	58
6.2.1 Touchscreen and input devices.....	58
6.2.2 Gestures and mouse actions.....	59
6.3 General operating elements and functions.....	61
6.4 ND 7000 – switch-on and switch-off.....	63
6.4.1 Switching on ND 7000.....	63
6.4.2 Activating and deactivating the energy saving mode.....	63
6.4.3 Switching off ND 7000.....	64
6.5 User login and logout.....	64
6.5.1 User login.....	65
6.5.2 User logout.....	65
6.6 Setting the language.....	65
6.7 Performing a reference mark search after startup.....	66
6.8 User interface.....	66
6.8.1 User interface after switch-on.....	67
6.8.2 Main menu of the user interface.....	68
6.8.3 Manual operation menu.....	70
6.8.4 MDI menu.....	72
6.8.5 File management menu.....	75
6.8.6 User login menu.....	76
6.8.7 Settings menu.....	77
6.8.8 Switch-off menu.....	78
6.9 Position display.....	78
6.9.1 Operating elements of the position display.....	78
6.9.2 Position display functions.....	79
6.10 Status bar.....	82
6.10.1 Operating elements of the status bar.....	82
6.10.2 Adjusting settings in the quick access menu.....	83
6.10.3 Stopwatch.....	84

6.10.4	Calculator.....	84
6.10.5	Auxiliary functions in Manual operation mode.....	85
6.11	OEM bar.....	86
6.11.1	Operating elements of the OEM bar.....	86
6.11.2	Calling functions of the OEM bar.....	87
6.12	Messages and audio feedback.....	88
6.12.1	Messages.....	88
6.12.2	Wizard.....	90
6.12.3	Audio feedback.....	90
7	Commissioning.....	91
7.1	Overview.....	92
7.2	Logging in for commissioning.....	92
7.3	Steps for commissioning.....	94
7.3.1	Selecting the Application.....	94
7.3.2	Basic settings.....	94
7.3.3	Configuring the axes.....	95
7.3.4	Using M functions.....	104
7.3.5	Configuring a touch probe (in the Milling application mode).....	105
7.4	OEM area.....	106
7.4.1	Adding documentation.....	106
7.4.2	Adding a startup screen.....	107
7.4.3	Generating a Text database.....	108
7.4.4	Configuring the OEM bar.....	110
7.4.5	Adjusting the display.....	115
7.4.6	Back up OEM specific folders and files.....	115
7.4.7	Configuring the unit for screenshots.....	116
7.5	Back up settings.....	117
7.6	Back up user files.....	118

8	Setup	119
8.1	Overview	120
8.2	Logging in for setup	121
8.3	Single steps for setup	123
8.3.1	Basic settings	123
8.3.2	Preparing machining processes (optional)	138
8.4	Back up settings	148
8.5	Back up user files	149
9	Milling – Quick Start	151
9.1	Overview	152
9.2	Logging in for Quick Start	153
9.3	Requirements	154
9.4	Determining the preset (manual operation mode)	156
9.5	Machining a through hole (manual operation mode)	157
9.5.1	Predrilling the through hole	157
9.5.2	Drilling out the through hole	158
9.6	Machining a rectangular pocket (MDI mode of operation)	159
9.6.1	Defining the rectangular pocket	160
9.6.2	Milling the rectangular pocket	161
9.7	Machining a fit (MDI mode of operation)	162
9.7.1	Defining the fit	162
9.7.2	Reaming the fit	163
9.8	Determining the preset (manual operation mode)	164
9.9	Drilling a circular hole pattern (MDI mode)	165
9.9.1	Defining the circular hole pattern	166
9.9.2	Drilling the circular hole pattern	166
9.10	Drilling a circular hole pattern (MDI operation)	167
9.10.1	Defining the circular hole pattern	167
9.10.2	Drilling the row of holes	168

10 Turning – Quick Start	169
10.1 Overview.....	170
10.2 Logging in for Quick Start.....	170
10.3 Requirements.....	171
10.4 Setting up the lathe.....	173
10.4.1 Measuring the reference tool.....	174
10.4.2 Tool measurement.....	175
10.4.3 Finding the preset.....	176
10.5 Roughing the outside contour.....	177
10.6 Turning the recesses.....	178
10.7 Finishing the outside contour.....	179
11 Milling – Manual operation	181
11.1 Overview.....	182
11.2 Conducting the reference mark search.....	183
11.3 Defining presets.....	184
11.3.1 Presetting by probing (in the Milling application mode).....	185
11.3.2 Presetting a position as datum.....	186
11.4 Creating a tool.....	187
11.5 Selecting a tool.....	188
12 Turning – Manual operation	189
12.1 Overview.....	190
12.2 Defining the upper limit for the spindle speed (in the Turning application mode).....	191
12.3 Conducting the reference mark search.....	192
12.4 Presetting a position as datum.....	193
12.5 Adding a tool.....	194
12.6 Selecting a tool.....	195

13 Milling – MDI mode.....	197
13.1 Overview.....	198
13.2 Block types.....	199
13.2.1 Positioning.....	199
13.2.2 Machining patterns.....	199
13.3 Executing blocks.....	203
13.4 Using the simulation window.....	205
13.4.1 Depiction as contour view.....	206
13.5 Working with the positioning aid.....	207
13.6 Executing an MDI block with Scaling factor.....	207
14 Turning – MDI mode.....	209
14.1 Overview.....	210
14.2 Defining the upper limit for the spindle speed (in the Turning application mode).....	211
14.3 Block types.....	212
14.3.1 Positioning.....	212
14.4 Executing blocks.....	212
14.5 Using the simulation window.....	214
14.5.1 Depiction as contour view.....	214
14.6 Working with the positioning aid.....	215
14.7 Executing an MDI block with Scaling factor.....	215
15 File Management.....	217
15.1 Overview.....	218
15.2 File types.....	219
15.3 Managing folders and files.....	219
15.4 Opening and viewing files.....	222
15.5 Exporting files.....	223
15.6 Importing files.....	224

16 Settings.....	225
16.1 Overview.....	226
16.1.1 Overview of the Settings menu.....	227
16.2 General.....	228
16.2.1 Device information.....	228
16.2.2 Screen.....	228
16.2.3 Display.....	229
16.2.4 Simulation window.....	230
16.2.5 Input devices.....	231
16.2.6 Sounds.....	231
16.2.7 Printers.....	232
16.2.8 Properties.....	232
16.2.9 Add printer.....	233
16.2.10 Remove printer.....	233
16.2.11 Date and time.....	233
16.2.12 Units.....	234
16.2.13 Copyrights.....	235
16.2.14 Service info.....	235
16.2.15 Documentation.....	235
16.3 Sensors.....	236
16.3.1 Touch probe.....	236
16.4 Interfaces.....	237
16.4.1 Network.....	237
16.4.2 Network drive.....	238
16.4.3 USB.....	238
16.4.4 Axes (switching functions).....	239
16.4.5 Position-dependent switching functions.....	240
16.5 User.....	241
16.5.1 OEM.....	241
16.5.2 Setup.....	242
16.5.3 Operator.....	243
16.5.4 Adding a User.....	243
16.6 Axes.....	244
16.6.1 Reference marks.....	244
16.6.2 Information.....	245
16.6.3 Switching functions.....	245
16.6.4 Inputs (Switching functions).....	246
16.6.5 Outputs (Switching functions).....	246
16.6.6 Adding M functions.....	247
16.6.7 Configuring M functions.....	247
16.6.8 Axes X, Y, Z, Zo.....	248

16.6.9	C axis.....	249
16.6.10	Encoder.....	250
16.6.11	Reference marks (Encoder).....	252
16.6.12	Reference point displacement.....	252
16.6.13	Linear error compensation (LEC).....	253
16.6.14	Segmented linear error compensation (SLEC).....	253
16.6.15	Create table of supporting points.....	254
16.6.16	Spindle axis S.....	254
16.6.17	Outputs (S).....	256
16.6.18	Inputs (S).....	256
16.6.19	Adding Gear stages.....	257
16.6.20	Configuring Gear stages.....	258

16.7 Service..... 259

16.7.1	Firmware information.....	259
16.7.2	Back up and restore.....	260
16.7.3	Firmware update.....	261
16.7.4	Reset.....	261
16.7.5	OEM area.....	262
16.7.6	OEM bar.....	262
16.7.7	Adding OEM-Bar items.....	263
16.7.8	Logo OEM bar item.....	264
16.7.9	Spindle speed OEM bar item.....	264
16.7.10	M function OEM bar item.....	265
16.7.11	Special functions OEM bar item.....	266
16.7.12	Document OEM bar item.....	267
16.7.13	Settings (OEM area).....	267
16.7.14	Program execution.....	267
16.7.15	Text database.....	268
16.7.16	Messages.....	268
16.7.17	Configuring M functions.....	269
16.7.18	Documentation.....	269
16.7.19	Software options.....	269
16.7.20	Back up and restore (OEM configuration).....	270

17 Service and Maintenance.....	271
17.1 Overview.....	272
17.2 Cleaning.....	272
17.3 Maintenance plan.....	273
17.4 Resuming operation.....	273
17.5 Updating the firmware.....	274
17.6 Restore settings.....	276
17.7 Reset all settings.....	277
17.8 Reset to shipping conditions.....	277
18 What to do if	279
18.1 Overview.....	280
18.2 System or power failure.....	280
18.2.1 Restoring the firmware.....	280
18.2.2 Restore settings.....	281
18.3 Malfunctions.....	281
18.3.1 Troubleshooting.....	282
19 Removal and Disposal.....	285
19.1 Overview.....	286
19.2 Removal.....	286
19.3 Disposal.....	286
20 Specifications.....	287
20.1 Overview.....	288
20.2 Product data.....	288
20.3 Product dimensions and mating dimensions.....	291
20.3.1 Product dimensions with Single-Pos stand.....	293
20.3.2 Product dimensions with Duo-Pos stand.....	294
20.3.3 Product dimensions with Multi-Pos stand.....	294
20.3.4 Product dimensions with Multi-Pos holder.....	295

21 Index.....296

22 List of Figures.....298

1

Fundamentals

1.1 Overview

This chapter contains information about the product and these instructions.

1.2 Information on the product

Product designation	ID	Firmware version	Index
ND 7000	1089178-xx, 1089179-xx	1235720.1.1.x	---

The ID label is provided on the back of the product.

Example:



- 1 Product designation
- 2 Index
- 3 Part number (ID)

1.3 Demo software for the product

ND 7000 Demo is software you can install on a computer independently of the device. ND 7000 Demo helps you to become familiar with, try out or present the functions of the device.

You can download the current version of the software here: www.heidenhain.de



To download the installation file from the HEIDENHAIN Portal, you need access rights to the **Software** portal folder in the directory of the appropriate product.

If you do not have access rights to the Portal's **Software** folder, you can request the access rights from your HEIDENHAIN contact person.

1.4 Documentation on the product

1.4.1 Validity of the documentation

Before using the documentation and the product, you need to verify that the documentation matches the product.

- ▶ Compare the part number and the index indicated in the documentation with the corresponding data given on the ID label of the product
- ▶ Compare the firmware version given in the documentation with the firmware version of the product

Further information: "Device information", Page 228

- > If the part numbers and indexes as well as the firmware versions match, the documentation is valid



If the part numbers and indexes do not match, so that the documentation is not valid, you will find the current documentation for the product at www.heidenhain.de.

1.4.2 Notes on reading the documentation

 WARNING
<p>Fatal accidents, personal injury or property damage caused by non-compliance with the documentation!</p> <p>Failure to comply with the documentation may result in fatal accidents, personal injury or property damage.</p> <ul style="list-style-type: none"> ▶ Read the documentation carefully from beginning to end ▶ Keep the documentation for future reference

The table below lists the components of the documentation in the order of priority for reading.

Documentation	Description
Addendum	<p>An addendum supplements or supersedes the corresponding contents of the Operating Instructions and, if applicable, of the Installation Instructions.</p> <p>If an addendum is included in the shipment, it has the highest priority for reading. All other contents of the documentation retain their validity.</p>
Installation Instructions	<p>The Installation Instructions contain all of the information and safety precautions needed for the proper mounting and installation of the product. The Installation Instructions are contained as an excerpt from the Operating Instructions in every delivery.</p> <p>The Installation Instructions have the second highest level of priority for reading.</p>
Operating Instructions	<p>The Operating Instructions contain all the information and safety precautions needed for the proper operation of the product according to its intended use. The Operating Instructions are included on the supplied storage medium and can also be downloaded in the download area from www.heidenhain.de. The Operating Instructions must be read before the unit is put into service.</p> <p>The Operating Instructions have the third highest level of priority for reading.</p>

Would you like to see any changes made, or have you found any errors?

We are continuously striving to improve our documentation for you. Please help us by sending your requests to the following e-mail address:

userdoc@heidenhain.de

1.4.3 Storage and distribution of the documentation

The instructions must be kept in the immediate vicinity of the workplace and must be available to all personnel at all times. The operating company must inform the personnel where these instructions are kept. If the instructions have become illegible, the operating company must obtain a new copy from the manufacturer.

If the product is given or resold to any other party, the following documents must be passed on to the new owner:

- Addendum (if supplied)
- Operating Instructions

1.5 About these instructions

These instructions provide all the information and safety precautions needed for the safe operation of the product.

1.5.1 Document category

Operating Instructions

These instructions are the **Operating Instructions** for the product.

The Operating Instructions

- Are oriented to the product life cycle
- Contain all information and safety precautions needed for the proper operation of the product according to its intended use

1.5.2 Target groups for the instructions

These instructions must be read and observed by every person who performs any of the following tasks:

- Mounting
- Installation
- Commissioning and configuration
- Operation
- Service, cleaning and maintenance
- Troubleshooting
- Removal and disposal

1.5.3 Target groups according to user types

The target groups of these instructions refer to the various user types of the product and their authorizations.

The product features the following user types:

OEM user

The **OEM** (Original Equipment Manufacturer) user has the highest level of permissions. This user is allowed to configure the product's hardware (e.g. connection of encoders and sensors). He can create **Setup** and **Operator**-type users, and configure the **Setup** and **Operator** users. The **OEM** user cannot be duplicated or deleted. This user cannot be logged in automatically.

Setup user

The **Setup** user configures the product for use at the place of operation. This user can create **Operator**-type users. The **Setup** user cannot be duplicated or deleted. This user cannot be logged in automatically.

Operator user

The **Operator** user is permitted to use the basic functions of the product. An **Operator**-type user cannot create additional users, but is allowed to edit various operator-specific settings, such as his name or the language. A user of the **Operator** group can be logged in automatically as soon as the product is switched on.

1.5.4 Contents of the chapters

The table below shows:

- from which chapters these instructions are derived from
- which information the chapters of the instructions contain
- to which target groups the chapters of the instructions mainly apply

Section	Contents	Target group		
		OEM	Setup	Operator
	This chapter contains information about...			
1 "Fundamentals"	<ul style="list-style-type: none"> ■ ... this product ■ ... these instructions 	✓	✓	✓
2 "Safety"	... Safety regulations and safety measures <ul style="list-style-type: none"> ■ for mounting the product ■ for installing the product ■ for operating the product 	✓	✓	✓
3 "Transport and Storage"	<ul style="list-style-type: none"> ■ ... transporting the product ■ ... storing the product ■ ... items supplied with the product ■ ... accessories for the product 	✓	✓	
4 "Mounting"	... correct mounting of the product	✓	✓	
5 "Installation"	... correct installation of the product	✓	✓	

Section	Contents	Target group		
		OEM	Setup	Operator
	This chapter contains information about...			
6 "Basic Operation"	<ul style="list-style-type: none"> ■ ... the operating elements of the product user interface ■ ... the user interface of the product ■ ... basic functions of the product 	✓	✓	✓
7 "Commissioning"	... commissioning the product	✓		
8 "Setup"	... correct setup of the product		✓	
9 "Milling Quick Start"	... a typical manufacturing process based on a sample workpiece			✓
10 "Turning Quick Start"	... a typical manufacturing process based on a sample workpiece			✓
11 "Milling Manual operation"	<ul style="list-style-type: none"> ■ ... the "manual" mode of operation ■ ... using the "manual" mode of operation 		✓	✓
12 "Turning Manual operation"	<ul style="list-style-type: none"> ■ ... the "manual" mode of operation ■ ... using the "manual" mode of operation 		✓	✓
13 "Milling MDI mode"	<ul style="list-style-type: none"> ■ ... the "MDI" mode of operation ■ ... using the "MDI" mode of operation ■ ... executing single blocks 		✓	✓
14 "Turning MDI mode"	<ul style="list-style-type: none"> ■ ... the "MDI" mode of operation ■ ... using the "MDI" mode of operation ■ ... executing single blocks 		✓	✓
15 "File Management"	... the functions of the "File management" menu	✓	✓	✓
16 "Settings"	... setting options and associated setting parameters for the product	✓	✓	✓
17 "Service and Maintenance"	... general maintenance work on the product	✓	✓	✓
18 "What to do if ..."	<ul style="list-style-type: none"> ■ ... causes of faults or malfunctions of the product ■ ... corrective actions for faults or malfunctions of the product 	✓	✓	✓
19 "Removal and Disposal"	<ul style="list-style-type: none"> ■ ... disassembly and disposal of the product ■ ... environment protection specifications 	✓	✓	✓
20 "Specifications"	<ul style="list-style-type: none"> ■ ... the technical data of the product ■ ... product dimensions and mating dimensions (drawings) 	✓	✓	✓
21 "Index"	This chapter enables accessing the content of these instructions according to specific topics.	✓	✓	✓

1.5.5 Notes in this documentation

Safety precautions

Precautionary statements warn of hazards in handling the product and provide information on their prevention. Precautionary statements are classified by hazard severity and divided into the following groups:

DANGER

Danger indicates hazards for persons. If you do not follow the avoidance instructions, the hazard **will result in death or severe injury**.

WARNING

Warning indicates hazards for persons. If you do not follow the avoidance instructions, the hazard **could result in death or serious injury**.

CAUTION

Caution indicates hazards for persons. If you do not follow the avoidance instructions, the hazard **could result in minor or moderate injury**.

NOTICE

Notice indicates danger to material or data. If you do not follow the avoidance instructions, the hazard **could result in things other than personal injury, such as property damage**.

Informational notes

Informational notes ensure reliable and efficient operation of the product. Informational notes are divided into the following groups:



The information symbol indicates a **tip**.
A tip provides additional or supplementary information.



The gear symbol indicates that the function described **depends on the machine**, e.g.

- Your machine must feature a certain software or hardware option
- The behavior of the functions depends on the configurable machine settings



The book symbol represents a **cross reference** to external documentation, e.g. the documentation of your machine tool builder or other supplier.

1.5.6 Symbols and fonts used for marking text

In these instructions the following symbols and fonts are used for marking text:

Depiction	Meaning
▶ ...	Identifies an action and the result of this action
> ...	Example: ▶ Tap OK > The message is closed
■ ...	Identifies an item of a list
■ ...	Example: ■ TTL interface ■ EnDat interface ■ ...
Bold	Identifies menus, displays and buttons Example: ▶ Tap Shut down > The operating system shuts down ▶ Turn the power switch off

2

Safety

2.1 Overview

This chapter provides important safety information needed for the proper operation of the unit.

2.2 General safety precautions

General accepted safety precautions, in particular the applicable precautions relating to the handling of live electrical equipment, must be followed when operating the system. Failure to observe these safety precautions may result in personal injury or damage to the product.

It is understood that safety rules within individual companies vary. If a conflict exists between the material contained in these instructions and the rules of a company using this system, the more stringent rules take precedence.

2.3 Intended use

The products of the ND 7000 series are advanced digital readouts for use on manually operated machine tools. In combination with linear and angle encoders, digital readouts of the ND 7000 series return the position of the tool in more than one axis and provide further functions for operating the machine tool.

The products of this series

- must only be used in commercial applications and in an industrial environment
- must be mounted on a suitable stand or holder to ensure the correct and intended operation of the product
- are intended for indoor use in an environment in which the contamination caused by humidity, dirt, oil and lubricants complies with the requirements of the specifications



The products support the use of peripheral devices from different manufacturers. HEIDENHAIN cannot make any statements on the intended use of these devices. The information on their intended use, which is provided in the associated documentations, must be observed.

2.4 Improper use

In particular, the products of the ND 7000 series must not be used in the following applications:

- Use and storage outside the operating conditions specified in "Specifications"
- Outdoor use
- Use in potentially explosive atmospheres
- Use of the products of the ND 7000 series as part of a safety function

2.5 Personnel qualification

The personnel for mounting, installation, operation, service, maintenance and removal must be appropriately qualified for this work and must have obtained sufficient information from the documentation supplied with the product and with the connected peripherals.

The personnel required for the individual activities to be performed on the product are indicated in the respective sections of these instructions.

The personnel groups are specified in detail as follows with regard to their qualifications and tasks.

Operator

The operator uses and operates the product within the framework specified for the intended use. He is informed by the operating company about the special tasks and the potential hazards resulting from incorrect behavior.

Qualified personnel

The qualified personnel are trained by the operating company to perform advanced operation and parameterization. The qualified personnel have the required technical training, knowledge and experience and know the applicable regulations, and are thus capable of performing the assigned work regarding the application concerned and of proactively identifying and avoiding potential risks.

Electrical specialist

The electrical specialist has the required technical training, knowledge and experience and knows the applicable standards and regulations, and is thus capable of performing work on electrical systems and of proactively identifying and avoiding potential risks. Electrical specialists have been specially trained for the environment they work in.

Electrical specialists must comply with the provisions of the applicable legal regulations on accident prevention.

2.6 Obligations of the operating company

The operating company owns or leases the product and the peripherals. It is responsible that the intended use is complied with at all times.

The operating company must:

- Assign the different tasks to be performed on the product to appropriate, qualified and authorized personnel
- Verifiably train the personnel in the authorizations and tasks
- Provide all materials and means necessary in order for the personnel to complete the assigned tasks
- Ensure that the product is operated only when in perfect technical condition
- Ensure that the product is protected from unauthorized use

2.7 General safety precautions



The safety of any system incorporating the use of this product is the responsibility of the assembler or installer of the system.





The product supports the use of a wide variety of peripheral devices from different manufacturers. HEIDENHAIN cannot make any statements on the specific safety precautions to be taken for these devices. The safety precautions provided in the respective documentations must be observed. If there is no documentation at hand, it must be obtained from the manufacturers concerned.

The specific safety precautions required for the individual activities to be performed on the product are indicated in the respective sections of these instructions.

2.7.1 Symbols on the product

The following symbols are used to identify the product:

Symbol	Meaning
	Observe the safety precautions regarding electricity and power connection before you connect the product.
	Functional ground connection as per IEC/EN 60204-1. Observe the information on installation.
	Product seal. Breaking or removing the product seal will result in forfeiture of warranty and guarantee.

2.7.2 Electrical safety precautions

WARNING

Hazard of contact with live parts when opening the unit.

This may result in electric shock, burns or death.

- ▶ Never open the housing
- ▶ Only the manufacturer is permitted to access the inside of the product

WARNING

Hazard of dangerous amount of electricity passing through the human body upon direct or indirect contact with live electrical parts.

This may result in electric shock, burns or death.

- ▶ Work on the electrical system and live electrical components is to be performed only by trained specialists
- ▶ For power connection and all interface connections, use only cables and connectors that comply with applicable standards
- ▶ Have the manufacturer exchange defective electrical components immediately
- ▶ Regularly inspect all connected cables and all connections on the product. Defects, such as loose connections or scorched cables, must be removed immediately

NOTICE

Damage to internal parts of the product!

If you open the product, the warranty and the guarantee will be void.

- ▶ Never open the housing
- ▶ Only the product manufacturer is permitted to access the inside of the product

3

**Transport and
Storage**

3.1 Overview

This chapter contains information for the transportation and storage of the product and provides an overview of the items supplied and the available accessories of the product.



The following steps must be performed only by qualified personnel.

Further information: "Personnel qualification", Page 27

3.2 Unpacking

- ▶ Open the top lid of the box
- ▶ Remove the packaging materials
- ▶ Unpack the contents
- ▶ Check the delivery for completeness
- ▶ Check the delivery for damage

3.3 Items supplied and accessories

3.3.1 Items supplied

The following items are included in delivery:

Name	Description
Product	Digital Readout ND 7000
Operating Instructions	PDF issue of the Operating Instructions on a memory medium in the currently available languages
Installation Instructions	Printed issue of the Installation Instructions in the currently available languages
Addendum (optional)	Supplements or supersedes the contents of the Operating Instructions and, if applicable, of the Installation Instructions.

3.3.2 Accessories

The following accessories are optionally available and can be ordered from HEIDENHAIN:

Accessories	Name	Description	ID
For installation			
	KT 130 edge finder	Touch probe for probing a workpiece (for setting presets)	283273-xx
	Power cable	Power cable with European plug (type F), length: 3 m	223775-01
	USB connecting cable	USB connecting cable for connector type A to type B	354770-xx
	Cables	For information on connecting cables, see "Cables and Connectors for HEIDENHAIN Products" brochure.	—
For mounting			
	Multi-Pos holder	Holder for fastening the device on an arm, continuously tiltable within an angle of 90°, fixing hole pattern 50 mm x 50 mm	1089230-08
	Duo-Pos stand	Stand for rigid mounting, inclination angle 20° or 45°, fixing hole pattern 50 mm x 50 mm	1089230-06
	Multi-Pos stand	Stand for continuously variable tilting with a tilting range of 90°, fixing hole pattern 50 mm x 50 mm	1089230-07
	Single-Pos stand	Stand for rigid mounting, inclination angle 20°, fixing hole pattern 50 mm x 50 mm	1089230-05

3.4 In case of damage in transit

- ▶ Have the shipping agent confirm the damage
- ▶ Keep the packaging materials for inspection
- ▶ Notify the sender of the damage
- ▶ Contact the distributor or machine manufacturer for replacement parts



If damage occurred during transit:

- ▶ Keep the packaging materials for inspection
- ▶ Contact HEIDENHAIN or the machine manufacturer

This applies also if damage occurred to requested replacement parts during transit.

3.5 Repackaging and storage

Repackage and store the product carefully in accordance with the conditions stated below.

3.5.1 Repackaging the product

Repackaging should correspond to the original packaging as closely as possible.

- ▶ Re-attach all mounting parts and dust protection caps to the product as received from the factory, or repackage them in the original packaging as received from the factory
- ▶ Repackage the product in such a way that
 - it is protected from impact and vibration during transit
 - it is protected from the ingress of dust or humidity
- ▶ Place all accessories that were included in the shipment in the original packaging
Further information: "Items supplied and accessories", Page 32
- ▶ Enclose all the documentation that was included in the original packaging
Further information: "Storage and distribution of the documentation", Page 19



If the product is returned for repair to the Service Department:

- ▶ Ship the product without accessories, without measuring devices and without peripherals

3.5.2 Storage of the product

- ▶ Package the product as described above
- ▶ Observe the specified ambient conditions
Further information: "Specifications", Page 287
- ▶ Inspect the product for damage after any transport or longer storage times

4

Mounting

4.1 Overview

This chapter describes the mounting of the product. It contains instructions about how to correctly mount the product on stands or holders.

i The following steps must be performed only by qualified personnel.
Further information: "Personnel qualification", Page 27

4.2 Assembly of the product

General mounting information

The mount for the mounting variants is provided on the rear panel. The mounting hole pattern corresponds to a grid of 50 mm x 50 mm.

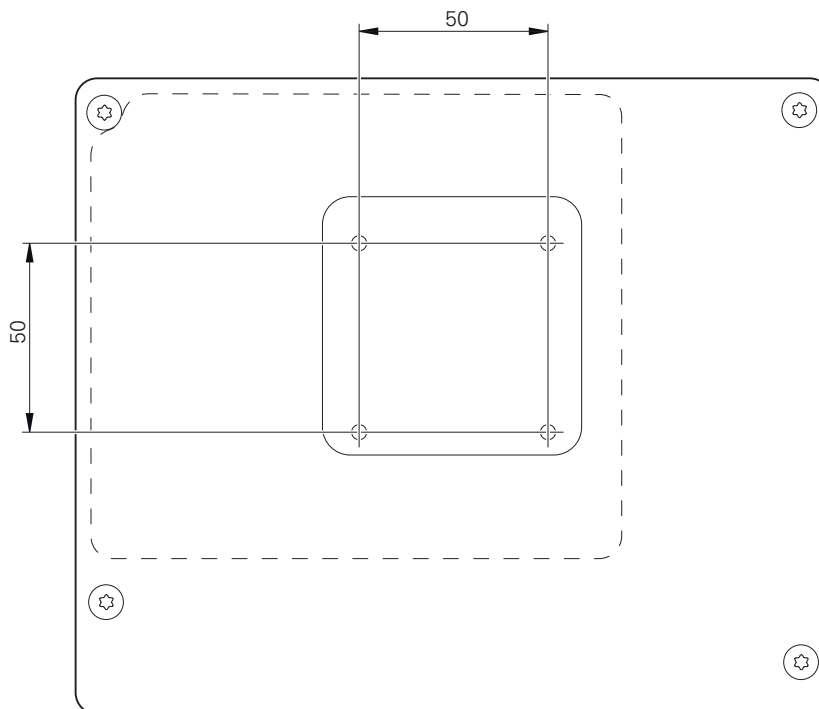

Figure 1: Dimensions of rear panel of the product

The material for attachment of the mounting variants on the device is included in delivery.

You will also need the following:

- Torx T20 screwdriver
- Torx T25 screwdriver
- Allen key, size 2.5 (Duo-Pos stand)
- Material for mounting on supporting surface

i The unit must be mounted to a stand or a holder to ensure the correct and intended use of the product.

4.2.1 Mounting on Single-Pos stand

You can attach the Single-Pos stand to the product at a 20° angle.

- ▶ Use the provided M4 x 8 ISO 14581 countersunk head screws to fasten the stand to the upper threaded holes on the rear panel

i Comply with the permissible tightening torque of 2.6 Nm

- ▶ Fasten the stand with two suitable screws from above to a supporting surface or
- ▶ Attach self-adhesive rubber pads to the underside of the stand
- ▶ Route the cable from behind through the opening of the stand and then through the lateral openings to the connections

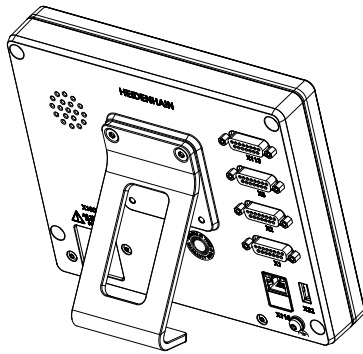

Figure 2: Product mounted on Single-Pos stand

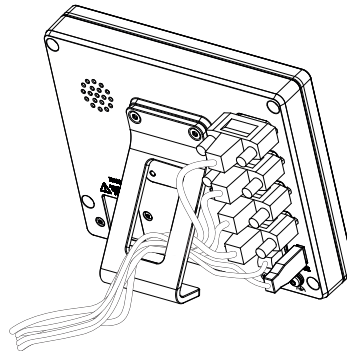

Figure 3: Cable routing on Single-Pos stand

Further information: "Product dimensions with Single-Pos stand", Page 293

Mounting on Duo-Pos stand

You can attach the Duo-Pos stand to the product at a 20° or 45° angle.

i If you screw the Duo-Pos stand into the product at a 45° angle, you must attach the product at the upper end of the mounting slots. Use a power cable cable with an angled connector.

- ▶ Use the provided M4 x 8 ISO 7380 hexagon socket screws to fasten the stand to the lower threaded holes on the rear panel

i Comply with the permissible tightening torque of 2.6 Nm

- ▶ Using the mounting slots (width = 4.5 mm), screw the stand to a supporting surface

or

- ▶ Set up the device freely at the desired location
- ▶ Route the cable from behind through the two supports of the stand and then through the lateral openings to the connections

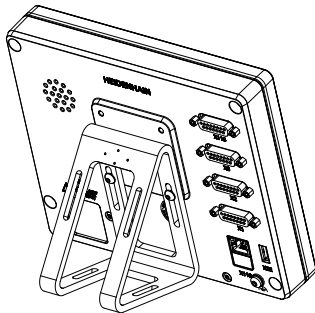

Figure 4: Product mounted on Duo-Pos stand

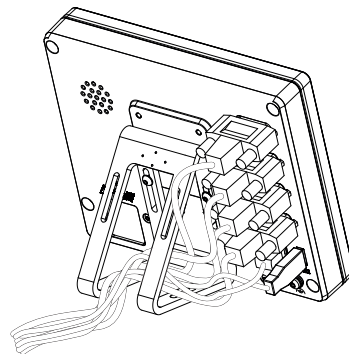

Figure 5: Cable routing on Duo-Pos stand

Further information: "Product dimensions with Duo-Pos stand", Page 294

4.2.2 Mounting on Multi-Pos stand

- ▶ Use the provided M4 x 8 ISO 14581 countersunk head screws (black) to fasten the stand to the threaded holes on the rear panel

i Comply with the permissible tightening torque of 2.6 Nm

- ▶ Using two M5 screws, you can also optionally screw the stand to a supporting surface from the bottom
- ▶ Adjust the desired angle of inclination
- ▶ To fix the stand: Tighten the T25 screw

i Comply with the tightening torque for screw T25

- Recommended tightening torque: 5.0 Nm
- Maximum permissible tightening torque: 15.0 Nm

- ▶ Route the cable from behind through the two supports of the stand and then through the lateral openings to the connections

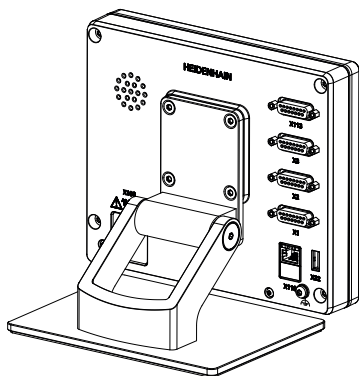

Figure 6: Product mounted on Multi-Pos stand

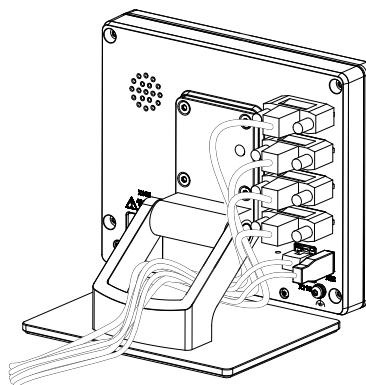

Figure 7: Cable routing on Multi-Pos stand

Further information: "Product dimensions with Multi-Pos stand", Page 294

4.2.3 Mounting on Multi-Pos holder

- ▶ Use the provided M4 x 8 ISO 14581 countersunk head screws (black) to fasten the holder to the threaded holes on the rear panel



Comply with the permissible tightening torque of 2.6 Nm

- ▶ Mount the holder with the supplied M8 screw, the washers, the handle and the M8 hexagon nut to an arm
- ▶ Adjust the desired angle of inclination
- ▶ To fix the holder: Tighten the T25 screw



Comply with the tightening torque for screw T25

- Recommended tightening torque: 5.0 Nm
- Maximum permissible tightening torque: 15.0 Nm

- ▶ Route the cable from behind through the two supports of the holder and then through the lateral openings to the connections

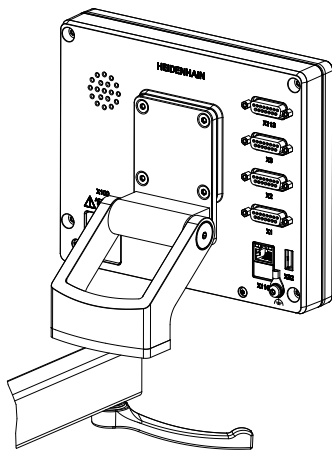

Figure 8: Product mounted on Multi-Pos holder

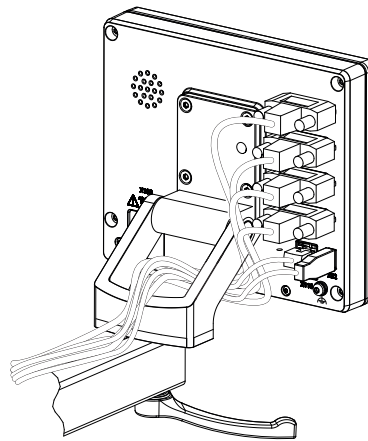

Figure 9: Cable routing on Multi-Pos holder

Further information: "Product dimensions with Multi-Pos holder", Page 295

5

Installation

5.1 Overview

This chapter describes the Installation of the product. It contains information about the product's connections and instructions about how to correctly connect the peripheral devices.



The following steps must be performed only by qualified personnel.

Further information: "Personnel qualification", Page 27

5.2 General information

NOTICE

Interference from sources of high electromagnetic emission!

Peripheral devices, such as frequency inverters or servo drives, may cause interference.

To increase the noise immunity to electromagnetic influences:

- ▶ Use the optional functional ground connection as per IEC/EN 60204-1
- ▶ Use only USB peripherals with continuous shielding, e.g. by metalized film and metal braiding or a metal housing. The degree of coverage provided by the braiding must be 85 % or higher. The shield must be connected around the entire circumference of the connectors (360° connection).

NOTICE

Engaging and disengaging connecting elements!

Risk of damage to internal components.

- ▶ Do not engage or disengage any connecting elements while the unit is under power

NOTICE

Electrostatic discharge (ESD)!

This product contains electrostatic sensitive components that can be destroyed by electrostatic discharge (ESD).

- ▶ It is essential to observe the safety precautions for handling ESD-sensitive components
- ▶ Never touch connector pins without ensuring proper grounding
- ▶ Wear a grounded ESD wristband when handling product connections

NOTICE

Damage to the product due to incorrect wiring!

The incorrect wiring of inputs or outputs can cause damage to the unit or to peripheral devices.

- ▶ Keep the pin layouts and specifications of the unit in mind.
- ▶ Assign only pins or wires that will be used

Further information: "Specifications", Page 287

5.3 Product overview

The connections on the rear panel of the device are protected by dust protection caps from contamination and damage.

NOTICE

Contamination or damage may result if the dust protection caps are missing!

If no dust protection caps are fitted to unused connections, this may impair the proper functioning of the contacts or destroy them.

- ▶ Remove dust protection caps only when connecting measuring devices or peripherals
- ▶ If you remove a measuring device or peripheral, re-attach the dust protection cap to the connection

i The type of connections for encoders may vary depending on the product version.

Rear panel without dust protection caps

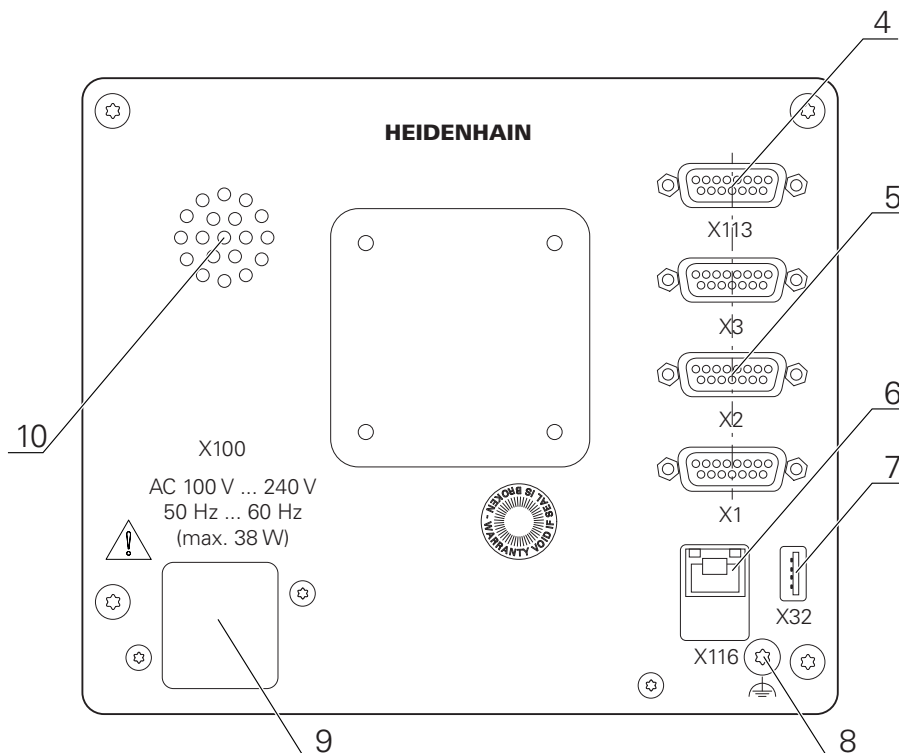

Figure 10: Rear panel on devices with ID 1089178-xx

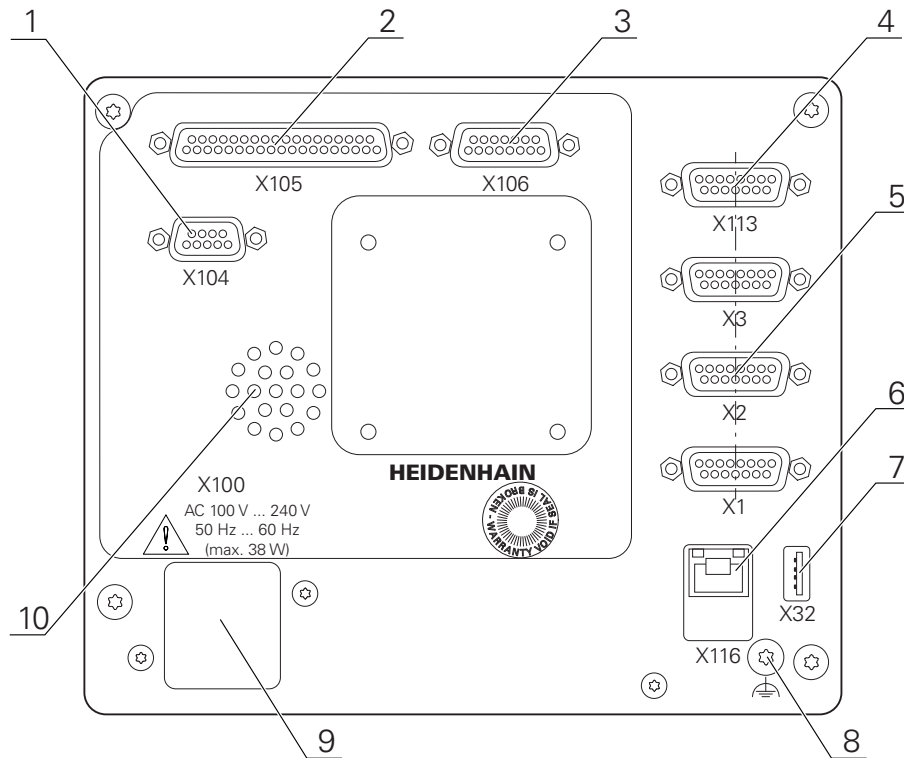

Figure 11: Rear panel on devices with ID 1089179-xx

Connections:

- 5** **X1 to X3:** Device variant with 15-pin D-sub connections for encoders with 1 V_{PP} interface
- 7** **X32:** USB 2.0 Hi-speed connection (type A) for printers, input devices or USB mass storage
- 10** Speaker
- 8** Functional ground connection as per IEC/EN 60204-1
- 6** **X116:** RJ45 Ethernet connection for communication and data exchange with subsequent systems or PC
- 4** **X113:** 15-pin D sub connection for touch probes (e.g., HEIDENHAIN touch probe)
- 9** **X100:** Power switch and power connection

Additional connections on devices with ID 1089179-xx:

- 2** **X105:** 37-pin D-sub connection for digital interface (DC 24 V; 24 switching inputs, 8 switching outputs)
- 3** **X106:** 15-pin D-sub connection for analog interface (4 inputs, 4 outputs)
- 1** **X104:** 9-pin D-sub connection for universal relay interface (2x relay changeover contacts)

5.4 Connecting encoders

- ▶ Remove and save the dust protection caps
- ▶ Route the cables depending on the mounting variant
Further information: "Assembly of the product", Page 36
- ▶ Connect the encoder cables tightly to the respective connections
Further information: "Product overview", Page 44
- ▶ If the cable connectors include mounting screws, do not overtighten them

Pin layout of X1, X2, X3

1 V _{PP}							
1	2	3	4	5	6	7	8
A+	0 V	B+	U _P	/	/	R-	/
9	10	11	12	13	14	15	
A-	Sensor 0 V	B-	Sensor U _P	/	R+	/	

5.5 Connecting touch probes

i The following touch probes can be connected to the unit:

- HEIDENHAIN KT 130 edge finder

Further information: "Items supplied and accessories", Page 32

- ▶ Remove and save the dust protection caps
- ▶ Route the cables depending on the mounting variant

Further information: "Assembly of the product", Page 36

- ▶ Connect the touch probe firmly

Further information: "Product overview", Page 44

- ▶ If the cable connectors include mounting screws, do not overtighten them

Pin layout of X 113

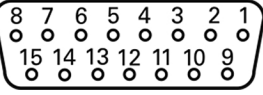
							
1	2	3	4	5	6	7	8
LED+	B 5 V	B 12 V	Dout 0	DC 12 V	DC 5 V	Din 0	GND
9	10	11	12	13	14	15	
Din 1	Din 2	TP	GND	TP	Din 3	LED-	

B – Probe signals, readiness

TP – Touch Probe, normally closed

Digital inputs:

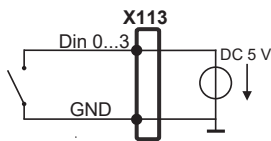

Digital outputs:

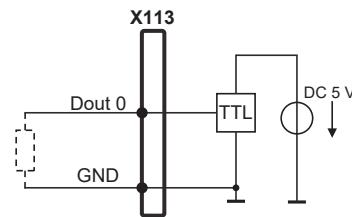

5.6 Wiring switching inputs and outputs



Depending on the peripherals to be connected, the connection work may need to be carried out by an electrical specialist.

Example: Safety Extra Low Voltage (SELV) exceeded

Further information: "Personnel qualification", Page 27



The encoder fulfills the requirements of standard IEC 61010-1 only if the power to the peripheral devices is supplied from a secondary circuit with current limitation as per IEC 61010-1^{3rd Ed.}, Section 9.4 or with power limitation as per IEC 60950-1^{2nd Ed.}, Section 2.5 or from a Class 2 secondary circuit as specified in UL1310.

In place of IEC 61010-1^{3rd Ed.}, Section 9.4, the corresponding sections of standards DIN EN 61010-1, EN 61010-1, UL 61010-1 and CAN/CSA-C22.2 No. 61010-1 and, in place of IEC 60950-1^{2nd Ed.}, Section 2.5, the corresponding sections of standards DIN EN 60950-1, EN 60950-1, UL 60950-1, CAN/CSA-C22.2 No. 60950-1 can be applied.

- ▶ Remove and save the dust protection caps
- ▶ Route the cables depending on the mounting variant

Further information: "Assembly of the product", Page 36

- ▶ Connect the connecting cables of the peripherals tightly to their connectors

Further information: "Product overview", Page 44

- ▶ If the cable connectors include mounting screws, do not overtighten them



The digital or analog inputs and outputs must be assigned in the device settings of the respective switching function.

Pin layout of X104

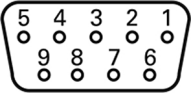
								
1	2	3	4	5	6	7	8	9
R-0 NO	R-0 NC	/	R-1 NO	R-1 NC	R-0 CO	/	/	R-1 CO

CO – Change Over
 NO – Normally Open
 NC – Normally Closed

Relay outputs:

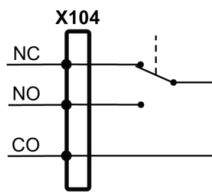

Pin layout of X 105

1	2	3	4	5	6	7	8
Din 0	Din 2	Din 4	Din 6	Din 8	Din 10	Din 12	Din 14
9	10	11	12	13	14	15	16
Din 16	Din 18	Din 20	Din 22	Dout 0	Dout 2	Dout 4	Dout 6
17	18	19	20	21	22	23	24
DC 24 V	DC 24 V	GND	Din 1	Din 3	Din 5	Din 7	Din 9
25	26	27	28	29	30	31	32
Din 11	Din 13	Din 15	Din 17	Din 19	Din 21	Din 23	Dout 1
33	34	35	36	37			
Dout 3	Dout 5	Dout 7	DC 24 V	GND			

Digital inputs:

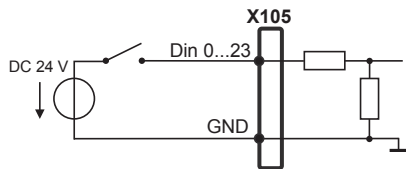

Digital outputs:

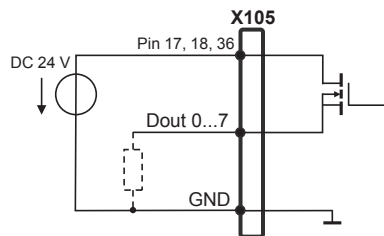

Pin layout of X 106

1	2	3	4	5	6	7	8
Aout 0+	Aout 1+	Aout 2+	Aout 3+	GND	GND	Ain 1	Ain 3
9	10	11	12	13	14	15	
Aout 0-	Aout 1-	Aout 2-	Aout 3-	DC 5 V	Ain 0	Ain 2	

Analog inputs:

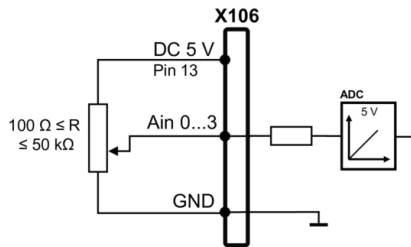

Analog outputs:

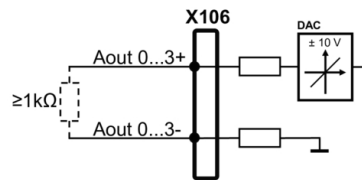

Pin layout of X 113

1	2	3	4	5	6	7	8
LED+	B 5 V	B 12 V	Dout 0	DC 12 V	DC 5 V	Din 0	GND
9	10	11	12	13	14	15	
Din 1	Din 2	TP	GND	TP	Din 3	LED-	

B – Probe signals, readiness

TP – Touch Probe, normally closed

Digital inputs:

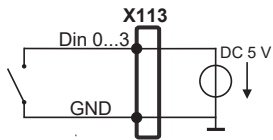

Digital outputs:

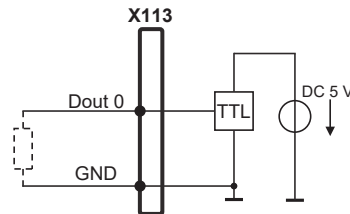

5.7 Connecting a printer

Connecting a USB printer

- ▶ Remove and save the dust protection caps
- ▶ Route the cables depending on the mounting variant
Further information: "Assembly of the product", Page 36
- ▶ Connect USB printer to USB type A connection (X32). Make sure the USB cable connector is fully inserted
Further information: "Product overview", Page 44

Pin layout X32

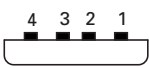
			
1	2	3	4
DC 5 V	Data (-)	Data (+)	GND

Connecting an Ethernet printer

- ▶ Remove and save the dust protection caps
- ▶ Route the cables depending on the mounting variant
Further information: "Assembly of the product", Page 36
- ▶ Connect the Ethernet printer to the Ethernet port X116 using a standard CAT.5 cable. The cable connector must firmly engage in the port
Further information: "Product overview", Page 44

Pin layout of X116

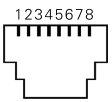
							
1	2	3	4	5	6	7	8
D1+ (TX+)	D1- (TX-)	D2+ (RX+)	D3+	D3-	D2- (RX-)	D4+	D4-

5.8 Connecting input devices

- ▶ Remove and save the dust protection caps
- ▶ Route the cables depending on the mounting variant
Further information: "Assembly of the product", Page 36
- ▶ Connect USB mouse or USB keyboard to USB type A connection (X32). Make sure the USB cable connector is fully inserted
Further information: "Product overview", Page 44

Pin layout X32

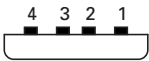
			
1	2	3	4
DC 5 V	Data (-)	Data (+)	GND

5.9 Connecting a network peripheral

- ▶ Remove and save the dust protection caps
- ▶ Route the cables depending on the mounting variant

Further information: "Assembly of the product", Page 36

- ▶ Connect the network peripheral to Ethernet port X116 using a standard CAT.5 cable. The cable connector must firmly engage in the port

Further information: "Product overview", Page 44

Pin layout of X116

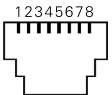
							
1	2	3	4	5	6	7	8
D1+ (TX+)	D1- (TX-)	D2+ (RX+)	D3+	D3-	D2- (RX-)	D4+	D4-

5.10 Connecting the line voltage

WARNING

Risk of electric shock!

Improper grounding of electrical devices may result in serious personal injury or death by electric shock.

- ▶ Always use 3-wire power cables
- ▶ Make sure the ground wire is correctly connected to the ground of the building's electrical installations

WARNING

Fire hazard due to wrong power cable!



Use of a power cable that does not meet the requirements of the mounting location may cause a fire hazard.

- ▶ Use only a power cable that meets at least the national requirements of the respective country in which the product is mounted

- ▶ Use a power cable that meets the requirements to connect the power connection to a 3-wire grounded power outlet

Further information: "Product overview", Page 44

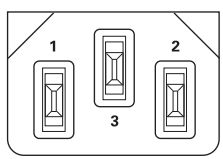
Pin layout X100

		
1	2	3
L/N	N/L	

6

Basic Operation

6.1 Overview

This chapter describes the user interface, operating elements, and basic functions of the unit.

6.2 Using the touchscreen and input devices

6.2.1 Touchscreen and input devices

The operating elements on the user interface of the unit are operated via a touchscreen or a connected USB mouse.

To enter data, you can use the screen keyboard of the touchscreen or a connected keyboard USB keyboard.

NOTICE

Malfunctions of the touchscreen caused by humidity or contact with water!

Humidity or water can impair the proper functioning of the touchscreen.

- ▶ Protect the touchscreen from humidity or contact with water

Further information: "Product data", Page 288

6.2.2 Gestures and mouse actions

To activate, switch or move the operating elements of the user interface, you can use the unit's touchscreen or a mouse. Gestures are used to operate the touchscreen and the mouse.

i The gestures for operating the touchscreen may differ from the gestures for operating the mouse.
If the gestures for operating the touchscreen differ from those for operating the mouse, then these instructions describe both operating options as alternative actions.
The alternative actions for operating the touchscreen or the mouse are identified by the following symbols:



Operation using the touchscreen



Operation using the mouse

The following overview describes the different gestures for operating the touchscreen or the mouse:

Tapping



Means touching the screen briefly with your fingertip



Means pressing the left mouse button once

The actions initiated by tapping include

- Selection of menus, features or parameters
- Entering characters with the screen keyboard
- Closing dialogs

Holding



Means touching the screen and holding your finger(s) on it for a few seconds



Means pressing the left mouse button once and holding it down

The actions initiated by holding are

- Quickly changing the values in input fields with plus and minus buttons

Dragging



Is a combination of long press and then swipe, moving a finger over the touchscreen when at least the starting point of motion is defined



Means pressing the left mouse button once and holding it down while moving the mouse; at least the starting point of the motion is defined

The actions initiated by dragging include

- Scrolling through lists and texts

6.3 General operating elements and functions

The operating elements described below are available for configuration and operating the product via the touchscreen or input devices.

Screen keyboard

With the screen keyboard, you can enter text into the input fields of the user interface. The displayed screen keyboard is either numeric or alphanumeric, depending on the input field.

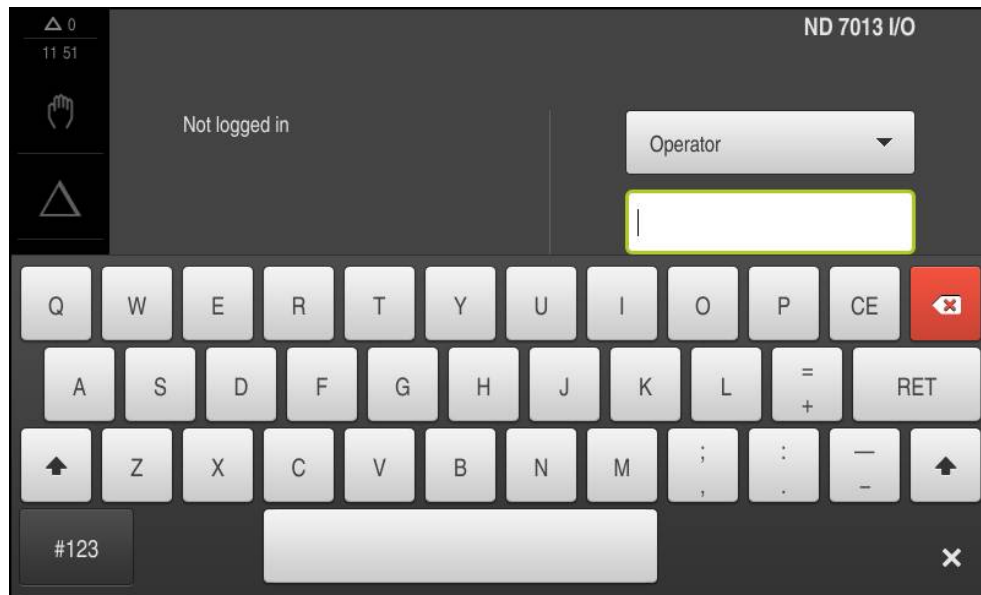



Figure 12: Screen keyboard

- ▶ To enter values, tap an input field
- > The input field is highlighted
- > The screen keyboard is displayed
- ▶ Enter text or numbers
- > In some input fields, a green check mark indicates that the entry is correct
- > If the entry is incomplete or incorrect, a red exclamation mark is displayed. The entry cannot be concluded in this case
- ▶ To apply the values, confirm the entry with **RET**
- > The values are displayed
- > The screen keyboard disappears

Input fields with plus and minus buttons

To adjust a numerical value, use the + (plus) and - (minus) buttons to the left and right of the numerical value.

- 
- ▶ Tap + or - until the desired value is displayed
 - ▶ Long-press + or - to scroll through the values more quickly
 - > The selected value is displayed

Toggle switch

Use the toggle switch to switch between functions.

- 
- ▶ Tap the desired function
 - > The active function is shown in green
 - > The inactive function is shown in light gray

Slide switch

With the sliding switch, you can activate or deactivate a function.



- ▶ Drag the sliding switch to the desired position or tap the sliding switch
- > The function is activated or deactivated

Drop-down list

Buttons that open drop-down lists are indicated by a triangle pointing down.

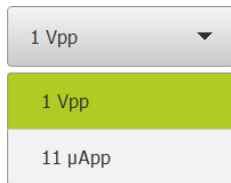

- ▶ Tap the button
- > The drop-down list opens
- > The active entry is highlighted in green
- ▶ Tap the desired entry
- > The selected entry is applied

Undo

With this button, you can undo the last action.

Processes that have already been concluded cannot be undone.

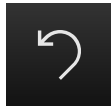

- ▶ Tap **Undo**
- > The last action is undone

Add

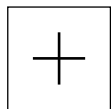

- ▶ To add a feature, tap **Add**
- > The new feature is added

Close

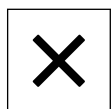

- ▶ Tap **Close** to close a dialog

Confirm

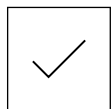

- ▶ Tap **Confirm** to conclude an activity

Back

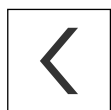

- ▶ Tap **Back** to return to the higher level in the menu structure

6.4 ND 7000 – switch-on and switch-off

6.4.1 Switching on ND 7000



Before using the product, you need to perform the commissioning and setup steps. Depending on the purpose of use, you may have to configure additional setup parameters.

Further information: "Commissioning", Page 91

- ▶ Turn the power switch on
The power switch is on the rear side of the unit
- > The unit powers up. This can take a moment
- > If automatic user login is active and the last user who logged in was of the **Operator** type, the user interface opens with the **Manual operation** menu
- > If automatic user login is not active, the **User login** menu is displayed
Further information: "User login and logout", Page 64

6.4.2 Activating and deactivating the energy saving mode

If you will not be using the unit for a while, you should activate the energy-saving mode. This switches the unit to an inactive state without interrupting the power supply. The screen is switched off in this state.

Activating energy-saving mode



- ▶ Tap **Switch off** in the main menu



- ▶ Tap **Energy-saving mode**
- > The screen switches off

Deactivating energy-saving mode



- ▶ Tap anywhere on the touchscreen
- > An arrow appears at the bottom of the screen
- ▶ Drag the arrow up
- > The screen is switched on and shows the user interface last displayed

6.4.3 Switching off ND 7000

NOTICE

Damage to the operating system!

Disconnecting the power source while the product is on can damage the operating system of the product.

- ▶ Use the **Switch-off** menu to shut down the product
- ▶ Do not disconnect the power source while the product is on
- ▶ Do not turn the power switch off until the product has shut down



- ▶ Tap **Switch off** in the main menu



- ▶ Tap **Shut down**
- > The operating system shuts down
- ▶ Wait until the following message appears on the screen:
You can switch off the device now.
- ▶ Turn the ND 7000 off at the power switch

6.5 User login and logout

In the **User login** menu, you can log in and out of the product as a user.

Only one user can be logged in to the product at a time. The logged-in user is displayed. Before a new user can log in, the logged-in user has to log out.



The product provides various authorization levels that grant the user full or restricted access to management and operation functionality.

6.5.1 User login



- ▶ Tap **User login** in the main menu
- ▶ Select the user in the drop-down list
- ▶ Tap the **Password** input field
- ▶ Enter the user's password

Further information: "Logging in for Quick Start", Page 153



If the password does not match the default password, ask a **Setup** user or **OEM** user for the assigned password.

If the password is no longer known, contact a HEIDENHAIN service agency.



- ▶ Confirm entry with **RET**
- ▶ Tap **Log in**
- > The user is logged in and the **Manual operation** menu is displayed

6.5.2 User logout



- ▶ Tap **User login** in the main menu



- ▶ Tap **Log out**
- > The user is logged out
- > All functions of the main menu are inactive, except for **Switch off**
- > The product can only be used again after a user has logged in

6.6 Setting the language

The default language for the user interface is English. You can switch the user interface to the desired language.



- ▶ Tap **Settings** in the main menu



- ▶ Tap **User**
- > The logged-in user is indicated by a check mark
- ▶ Select the logged-in user
- > The language selected for the user is indicated by a national flag in the **Language** drop-down list
- ▶ Select the flag for the desired language in the **Language** drop-down list
- > The user interface is displayed in the selected language

6.7 Performing a reference mark search after startup



If the unit is configured with the **Turning** application mode and a **spindle axis S**, then you must define an upper limit for the spindle speed prior to a possible machining operation.

Further information: "Defining the upper limit for the spindle speed (in the Turning application mode)", Page 191



If the reference mark search after unit start is active, then all of the unit's functions will be disabled until the reference mark search has been successfully completed.

Further information: "Reference marks (Encoder)", Page 252

If the reference mark search is active on the unit, then a wizard will ask you to traverse the reference marks of the axes.

- ▶ After logging in, follow the instructions of the wizard
- > The Reference symbol stops blinking upon successful completion of the reference mark search

Further information: "Operating elements of the position display", Page 78

Further information: "Activating the reference mark search", Page 95

6.8 User interface



The unit is available in different versions, which are variously equipped. The user interface and available functions may vary depending on the version.

6.8.1 User interface after switch-on

Factory default user interface

The illustration shows the user interface the way it looks when you switch on the product for the first time.

This user interface will also be displayed after resetting the product to the factory defaults.

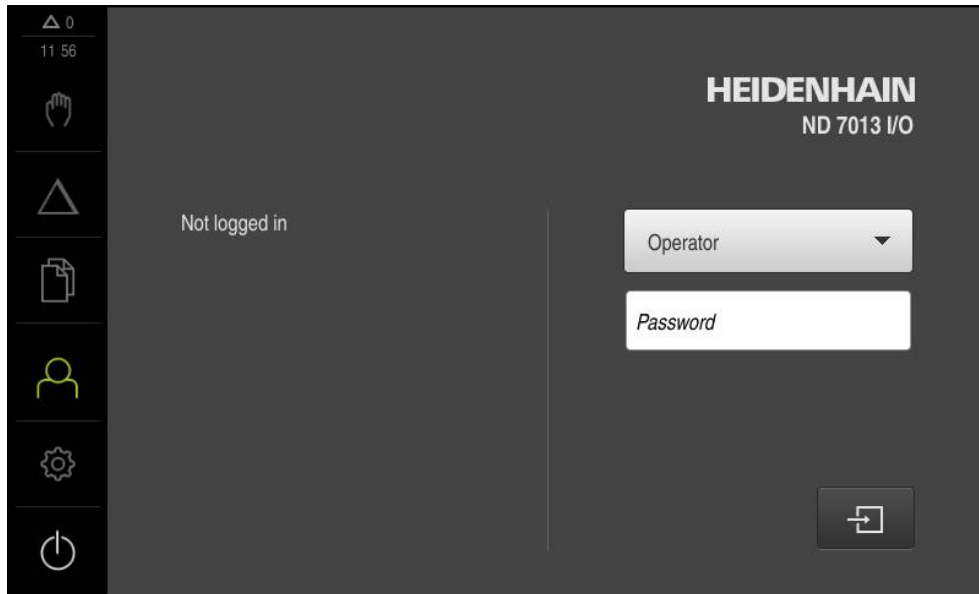

Figure 13: The user interface in the unit's factory default setting

User interface after startup

If automatic user login is active and the last user who logged in was of the **Operator** type, the **Manual operation** menu is displayed after the product has started up.

Further information: "Manual operation menu", Page 70

If automatic user login is not active, the product opens the **User login** menu.

Further information: "User login menu", Page 76

6.8.2 Main menu of the user interface

User interface (in Manual operation mode)

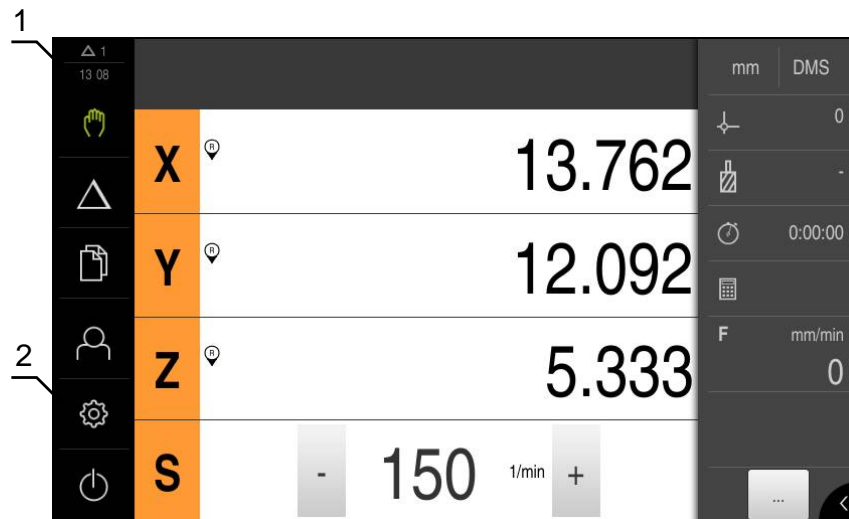









Figure 14: User interface (in Manual operation mode)

- 1 Message display area, displays the time and the number of unclosed messages
- 2 Main menu with operating elements

Operating elements of the main menu

The main menu is displayed regardless of the activated software options.

Operating element	Function
	<p>Message</p> <p>Display of an overview of all messages as well as the number of messages that have not been closed</p> <p>Further information: "Messages", Page 88</p>
	<p>Manual operation</p> <p>Manual positioning of machine axes</p> <p>Further information: "Manual operation menu", Page 70</p>
	<p>MDI mode</p> <p>Direct input of the desired axis movements (Manual Data Input); the distance to go is calculated and displayed</p> <p>Further information: "MDI menu", Page 72</p>
	<p>File management</p> <p>Management of the files that are available on the product</p> <p>Further information: "File management menu", Page 75</p>
	<p>User login</p> <p>Login and logout of the user</p> <p>Further information: "User login menu", Page 76</p>

Operating element	Function
	Settings Settings of the unit, such as setting up users, configuring sensors, and updating the firmware Further information: "Settings menu ", Page 77
	Switch-off Shutdown of the operating system or activation of energy-saving mode Further information: "Switch-off menu", Page 78

6.8.3 Manual operation menu

Activation



- ▶ Tap **Manual operation** in the main menu
- > The user interface for manual operation is displayed

Manual operation menu (in the Milling application mode)

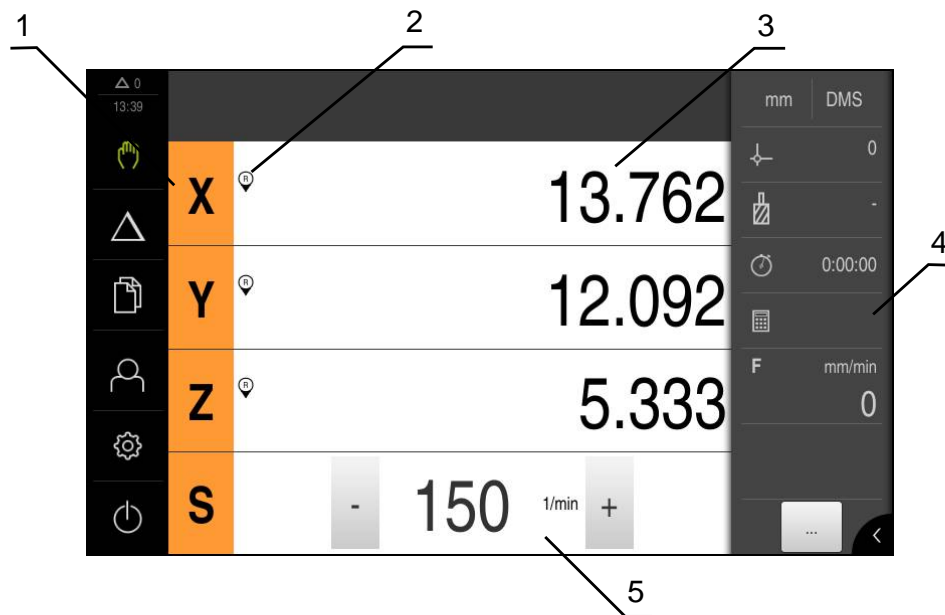
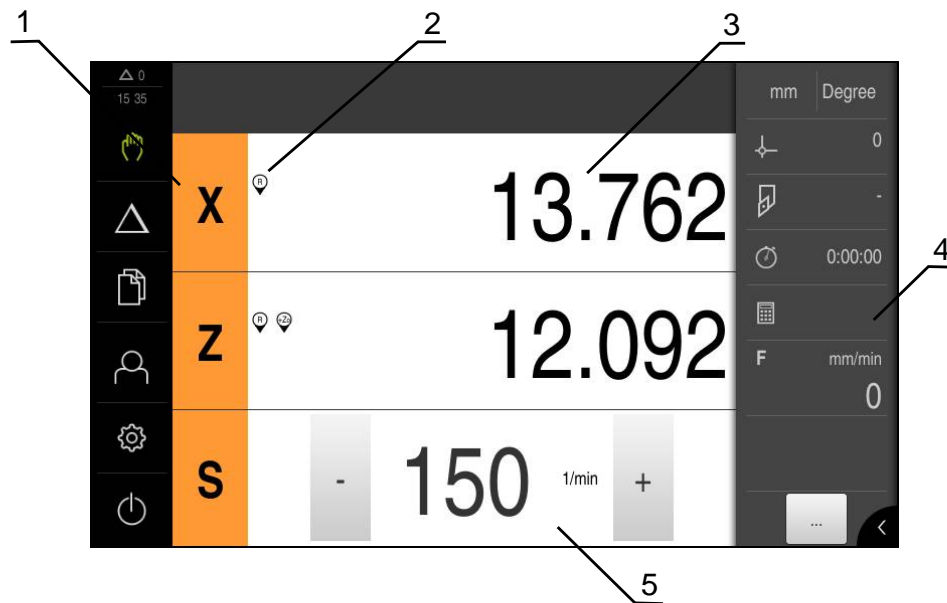

Figure 15: **Manual operation** menu in the milling application mode

- 1 Axis key
- 2 Reference
- 3 Position display
- 4 Status bar
- 5 Spindle speed (machine tool)

Manual operation menu (in the Turning application mode)Figure 16: **Manual operation** menu in the turning application mode

- 1 Axis key
- 2 Reference
- 3 Position display
- 4 Status bar
- 5 Spindle speed (machine tool)

In the **Manual operation** menu, the workspace shows the position values measured at the machine axes.

The status bar provides auxiliary functions.

Further information: "Milling Manual operation", Page 181

Further information: "Turning Manual operation", Page 189

6.8.4 MDI menu

Activation



► Tap **MDI** in the main menu

MDI mode menu (in the Milling application mode)

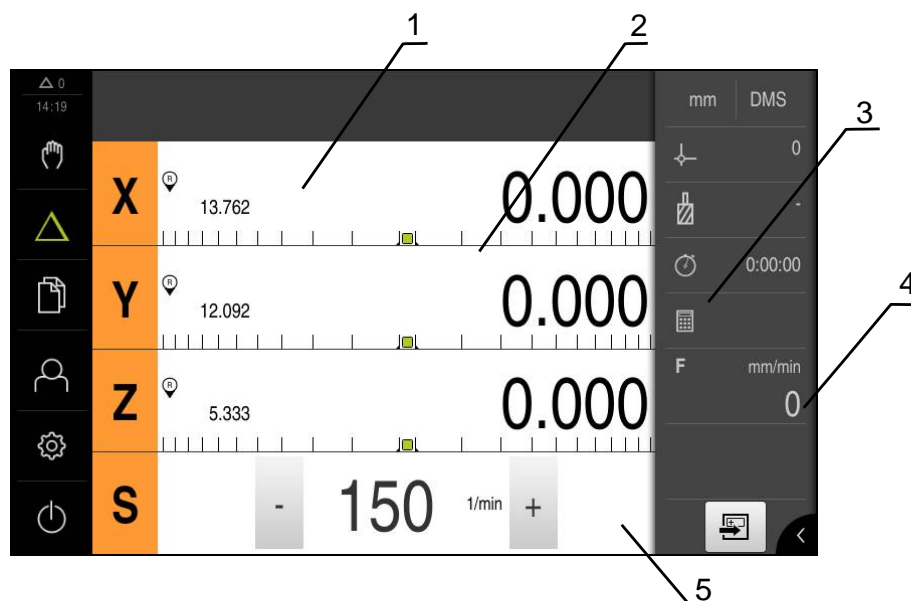
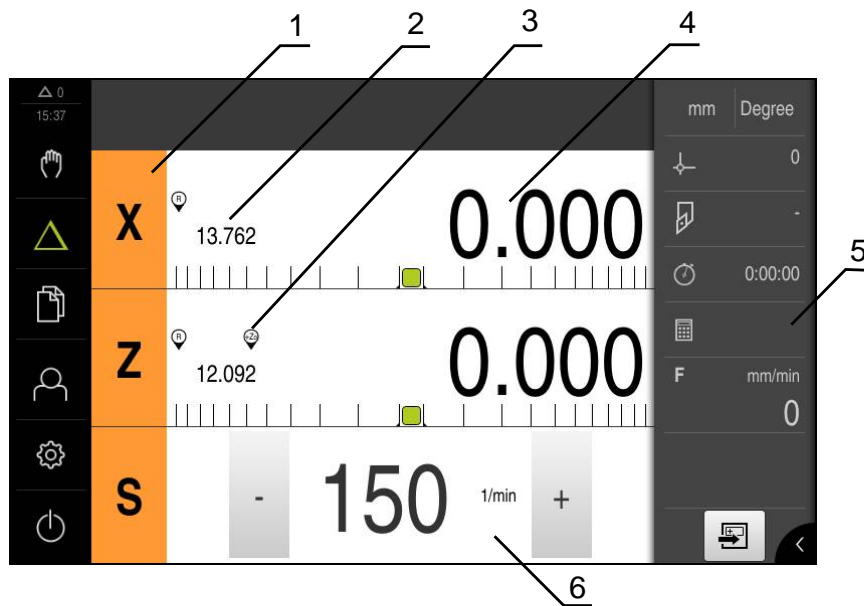

Figure 17: **MDI mode** menu in the milling application mode

- 1 Axis key
- 2 Actual position
- 3 Distance-to-go
- 4 Status bar
- 5 Spindle speed (machine tool)

MDI mode menu (in the Turning application mode)

Figure 18: **MDI mode** menu in the turning application mode

- 1 Axis key
- 2 Actual position
- 3 Coupled axes
- 4 Distance-to-go
- 5 Status bar
- 6 Spindle speed (machine tool)

MDI block dialog



- ▶ Tap **MDI** in the main menu



- ▶ Tap **Create** on the status bar
- The user interface for the MDI mode is displayed

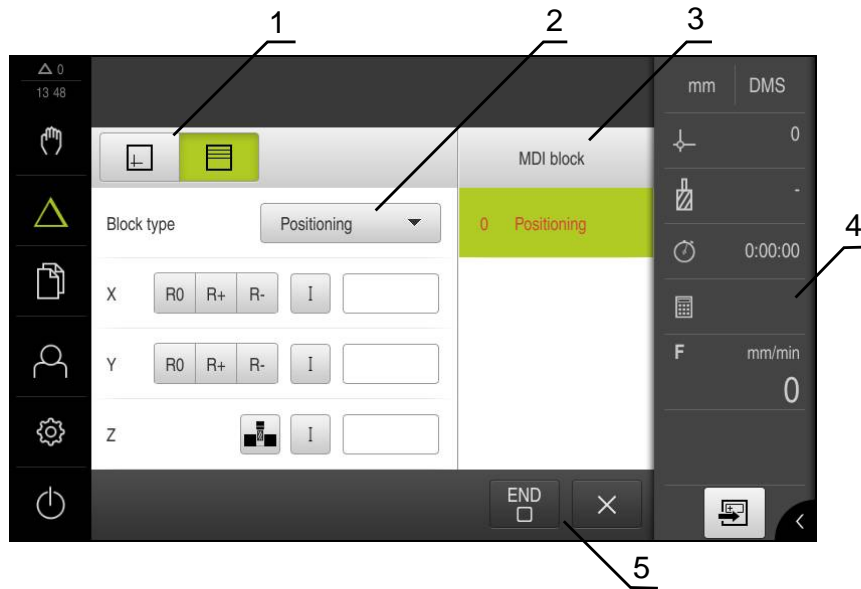

Figure 19: **MDI block** dialog

- 1 View bar
- 2 Block parameters
- 3 MDI block
- 4 Status bar
- 5 Block tools

The **MDI** (Manual Data Input) menu enables you to enter the desired axis movements directly. You specify the distance to the target point, and the distance to go is then calculated and displayed.

The status bar provides additional measured values and functions.

Further information: "Milling MDI mode", Page 197

Further information: "Turning MDI mode", Page 209

6.8.5 File management menu

Activation



- ▶ Tap **File management** in the main menu
- > The user interface for file management is displayed

Short description

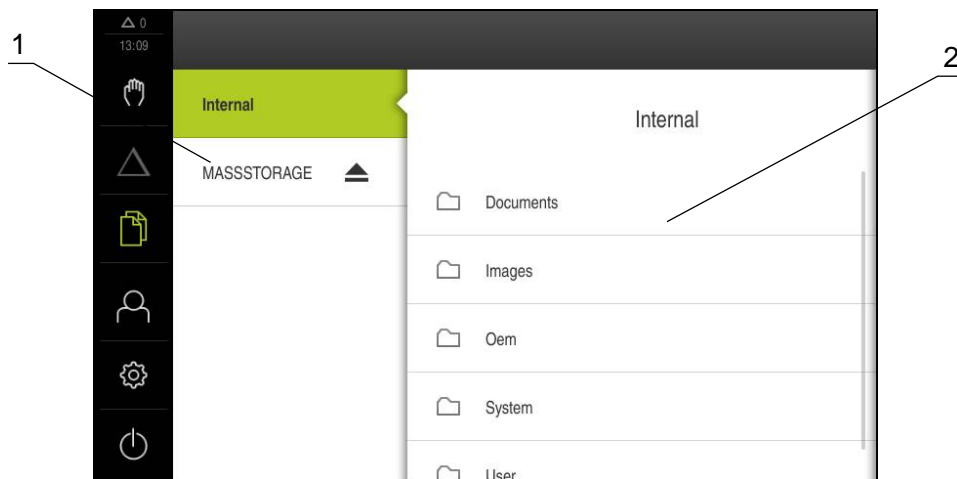

Figure 20: **File management** menu

- 1 List of available storage locations
- 2 List of folders in the selected storage location

The **File management** menu shows an overview of the files stored in the unit's memory.

Any connected USB mass storage devices (FAT32 format) or available network drives are shown in the list of storage locations. The USB mass storage devices and the network drives are displayed with their names or drive designations.

Further information: "File Management", Page 217

6.8.6 User login menu

Activation



- ▶ Tap **User login** in the main menu
- > The user interface for user login and logout is displayed

Short description

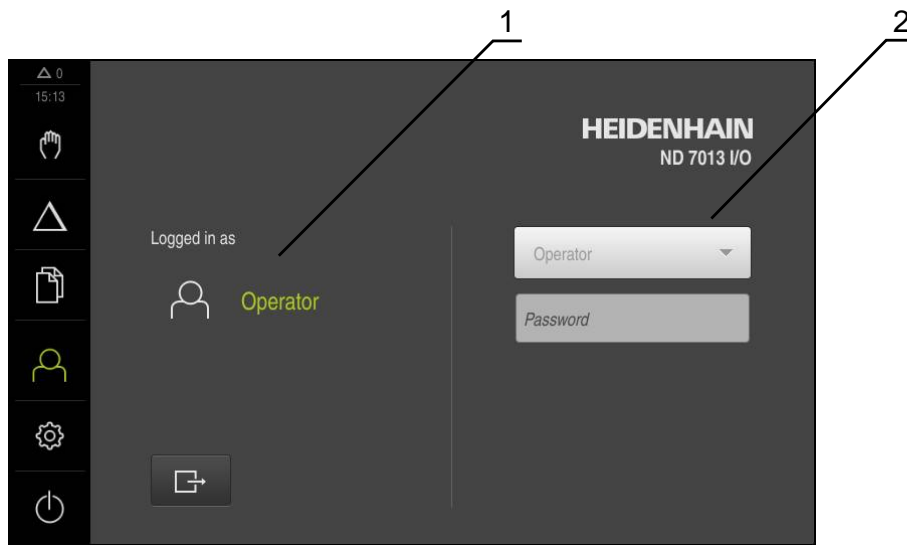

Figure 21: **User login** menu

- 1** Display of the logged-in user
- 2** User login

The **User login** menu shows the logged-in user in the column on the left. The login of a new user is displayed in the right-hand column.

To log in another user, the logged-in user must first log out.

Further information: "User login and logout", Page 64

6.8.7 Settings menu

Activation



- ▶ Tap **Settings** in the main menu
- > The user interface for the device settings is displayed

Short description

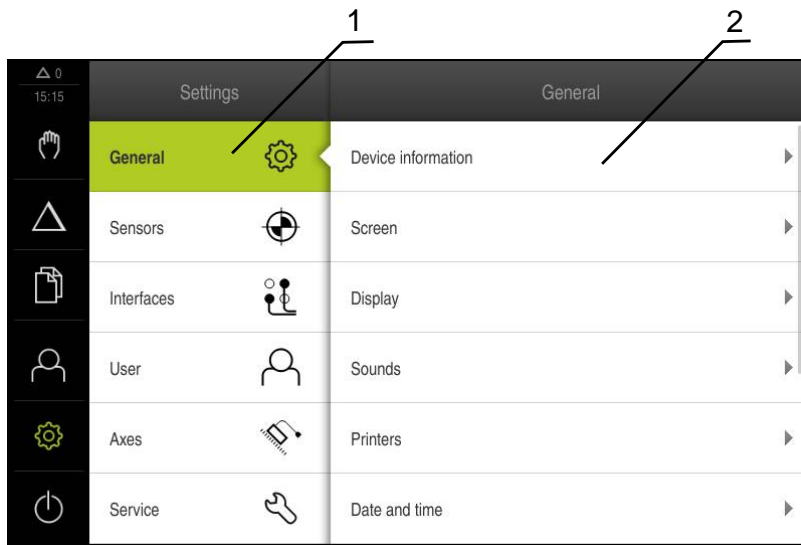

Figure 22: **Settings** menu

- 1 List of setting options
- 2 List of setting parameters

The **Settings** menu shows all options for configuring the product. With the setting parameters, you can adapt the product to on-site requirements.

Further information: "Settings", Page 225



The product provides various authorization levels that grant the user full or restricted access to management and operation functionality.

6.8.8 Switch-off menu

Activation



- ▶ Tap **Switch off** in the main menu
- The operating elements for shutting down the operating system, for activating the energy-saving mode and for activating the cleaning mode are displayed

Short description

The **Switch off** menu provides the following options:

Operating element	Function
	Shut down Shuts down the operating system
	Energy saving mode Switches the screen off and puts the operating system into energy-saving mode
	Cleaning mode Switches the screen off; the operating system continues unchanged

Further information: "ND 7000 – switch-on and switch-off", Page 63

Further information: "", Page 272









6.9 Position display

The unit's position display shows the axis positions and additional information about the configured axes (if applicable).

You can also couple the display of axes and have access to the spindle functions.

6.9.1 Operating elements of the position display

Symbol	Meaning
	Axis key Axis key functions: <ul style="list-style-type: none"> ■ Tapping the axis key: Opens the input field for position value (Manual operation) or dialog MDI block (MDI mode) ■ Holding down the axis key: sets the current position as zero point ■ Dragging the axis key to the right: opens menu if functions are available for the axis
	Position display shows the diameter of the radial machining axis X an Further information: "Display", Page 229
	Reference mark search performed successfully

Symbol	Meaning
	Reference mark search not performed or no reference mark detected
	Zo axis is coupled with the Z axis. Position display shows the sum of both position values Further information: "Coupling axes (in the Turning application mode)", Page 79
	Z axis is coupled with the Zo axis. Position display shows the sum of both position values
	Selected gear stage of the gear spindle Further information: "Setting the gear stage for gear spindles", Page 80
	Spindle speed cannot be achieved with selected gear stage ▶ Select a higher gear stage
	Spindle speed cannot be achieved with selected gear stage ▶ Select a lower gear stage
	The CSS (constant surface speed) spindle mode is activated Further information: "Setting the spindle mode (in the Turning application mode)", Page 81 If the icon is flashing, then the calculated spindle speed lies outside of the defined speed range. The desired surface speed cannot be attained. The spindle will continue to turn at the maximum or minimum speed
	In MDI mode, a scaling factor is applied to the axis Further information: "Adjusting settings in the quick access menu", Page 83



6.9.2 Position display functions

Coupling axes (in the Turning application mode)

In the **Turning** application mode, you can alternately couple the display of the **Z** axis and the **Zo** axis. For coupled axes, the position display shows the sum of the position values of both axes.

 Coupling is identical for the **Z** axis and **Zo** axis. The following describes only the coupling of the **Z** axis.

Coupling axes

-  ▶ In the working space, drag the **Z axis key** to the right
-  ▶ Tap **Couple**
- ▶ The **Zo** axis is now coupled with the **Z** axis
- ▶ The icon for the coupled axes is shown next to the **Z axis key**
- ▶ The position value for the coupled axes is shown as a sum

Decoupling axes



- ▶ In the working space, drag the **Z axis key** to the right



- ▶ Tap **Decouple**
- > The position value of both axes are shown independently of each other

Setting the spindle speed

 The following information applies only to units with ID number 1089179-xx.

You can control the spindle speed depending on the configuration of the connected machine tool.



- ▶ Tap or long-press **+** or **-** to set the spindle speed to the desired value
- or
- ▶ Tap the **Spindle speed** input field, enter the value and tap **RET** to confirm
- > The product applies the entered spindle speed as the nominal value and controls the spindle of the machine tool accordingly

Setting the gear stage for gear spindles

 The following information applies only to units with ID number 1089179-xx.

If your machine tool uses a gear spindle, then you can select the gear stage used.

 The selection of the gear stages can also be controlled via an external signal.
Further information: "Spindle axis S", Page 254



- ▶ In the working space, drag the **S axis key** to the right



- ▶ Tap **Gear stage**
- > The **Set gear stage** dialog appears
- ▶ Tap the desired gear stage



- ▶ Tap **Confirm**
- > The selected gear stage is now adopted as the new value
- ▶ Drag the **S axis key** to the left



- > The icon for the selected gear stage appears next to the **S axis key**

 If the desired spindle speed cannot be attained with the selected gear stage, then the gear stage icon will flash with an upward point arrow (higher gear stage) or with a downward pointing arrow (lower gear stage).

Setting the spindle mode (in the Turning application mode)



The following information applies only to units with ID number 1089179-xx.

In the **Turning** application mode, you can decide whether the unit uses the standard speed mode or **CSS** (constant surface speed) for the spindle mode.

In the **CSS** spindle mode, the unit calculates the speed such that the surface speed of the turning tool remains constant regardless of the workpiece geometry.

Activating the CSS spindle mode



- ▶ In the working space, drag the **S axis key** to the right



- ▶ Tap **CSS mode**
- > The **Activate CSS** dialog appears
- ▶ Enter the value for **Maximum spindle speed**



- ▶ Tap **Confirm**
- > The **CSS** spindle mode is activated
- > The spindle speed is shown in the unit of measure **m/min**



- ▶ Drag the **S axis key** to the left
- > The icon for the **CSS** spindle mode appears next to the **S axis key**

Activating the speed mode



- ▶ In the working space, drag the **S axis key** to the right



- ▶ Tap **Speed mode**
- > The **Activate speed mode** dialog appears
- ▶ Enter the value for **Maximum spindle speed**









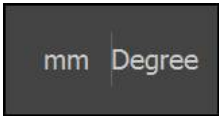

- ▶ Tap **Confirm**
- > The speed mode is activated
- > The spindle speed is shown in the unit of measure **rpm**
- ▶ Drag the **S axis key** to the left

6.10 Status bar

The status bar displays the feed rate and the traversing speed. The operating elements of the status bar also give you direct access to the preset table and tool table, as well as to the stopwatch and calculator features.

6.10.1 Operating elements of the status bar

The status bar provides the following operating elements:

Operating element	Function
	<p>Quick access menu</p> <p>For setting the units of measure for linear and angular values, configuring a scaling factor, and configuring the position display for radial machining axes (in the Turning application mode); tapping it opens the quick access menu</p> <p>Further information: "Adjusting settings in the quick access menu", Page 83</p>
	<p>Preset table</p> <p>Display of the current preset; tapping opens the preset table</p> <p>Further information: "Creating a preset table", Page 142</p>
	<p>Tool table</p> <p>Display of the current tool; tapping opens the tool table</p> <p>Further information: "Creating a tool table", Page 138</p>
	<p>Stopwatch</p> <p>Time display with Start / Stop function in h:mm:ss format</p> <p>Further information: "Stopwatch", Page 84</p>
	<p>Calculator</p> <p>Calculator with the most important mathematical functions, speed calculator, and taper calculator</p> <p>Further information: "Calculator", Page 84</p>
	<p>Feed rate</p> <p>Display of the actual feed rate of the currently fastest axis</p>
	<p>Additional functions</p> <p>Additional functions for Manual mode, depending on the configured application mode</p>
	<p>MDI block</p> <p>For creating machining blocks in MDI mode</p>

6.10.2 Adjusting settings in the quick access menu

With the quick access menu, you can adjust the following settings:

- Unit for linear values (**Millimeters** or **Inch**)
- Unit for angular values (**Radian**, **Decimal degrees** or **Deg-Min-Sec**)
- The display of **Radial machining axes** (**Radius** or **Diameter**)
- The **Scaling factor** by which the stored position is multiplied during execution of an **MDI block**

Setting the units of measure

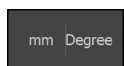

- ▶ Tap the **quick access menu** on the status bar
- ▶ Select the desired **Unit for linear values**
- ▶ Select the desired **Unit for angular values**



- ▶ Tap **Close** to close the quick access menu
- > The selected units are displayed in the **quick access menu**

The display of Radial machining axes

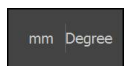

- ▶ Tap the **quick access menu** on the status bar
- ▶ Select the desired option
- ▶ Tap **Close** to close the quick access menu



- > If the **Diameter** option is selected, then the corresponding icon appears in the position display



Activating the Scaling factor

The **Scaling factor** is multiplied with the position stored in the block during execution of an **MDI block**. This allows you to mirror or scale an **MDI block** on one or more axes, without changing the block.

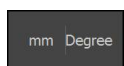



- ▶ Tap the **quick access menu** on the status bar
- ▶ To navigate to the desired setting, drag the view to the left
- ▶ Activate **Scaling factor** with the **ON/OFF** sliding switch
- ▶ Enter the desired **Scaling factor** for every axis
- ▶ Confirm each entry with **RET**
- ▶ Tap **Close** to close the quick access menu



- > For an active scaling factor $\neq 1$, the corresponding icon appears in the position display

6.10.3 Stopwatch

The status bar provides a stopwatch for measuring the machining times, etc. The stopwatch uses the time display format h:mm:ss and operates on the same principle as a standard stopwatch, i.e. it measures elapsed time.

Operating element	Function
	<p>Start</p> <p>Starts time measurement or resumes time measurement after Pause</p>
	<p>Pause</p> <p>Interrupts time measurement</p>
	<p>Stop</p> <p>Stops time measurement and resets it to 0:00:00</p>







6.10.4 Calculator

For the purpose of calculations, the unit's standard features in the status bar include a calculator with the most important mathematical functions. You can also select a speed calculator and taper calculator. To enter the numeric values, use the numeric keys as on a normal computer.

Calculator	Function	Application mode
<div style="border: 1px solid #ccc; padding: 2px;">Standard</div> <div style="border: 1px solid #ccc; padding: 2px; margin-top: 1px;">Speed calculator</div> <div style="border: 1px solid #ccc; padding: 2px; margin-top: 1px;">Taper calculator</div>	<p>Standard</p> <p>Contains the most important mathematical functions</p>	<p>Milling</p> <p>Turning</p>
<div style="border: 1px solid #ccc; padding: 2px;">Standard</div> <div style="border: 1px solid #ccc; padding: 2px; margin-top: 1px; background-color: #92d050;">Speed calculator</div> <div style="border: 1px solid #ccc; padding: 2px; margin-top: 1px;">Taper calculator</div>	<p>Speed calculator</p> <ul style="list-style-type: none"> ▶ Enter the Diameter (mm) and Cutting speed (m/min) in the provided fields > The speed is calculated automatically 	<p>Milling</p> <p>Turning</p>
<div style="border: 1px solid #ccc; padding: 2px;">Standard</div> <div style="border: 1px solid #ccc; padding: 2px; margin-top: 1px;">Speed calculator</div> <div style="border: 1px solid #ccc; padding: 2px; margin-top: 1px; background-color: #92d050;">Taper calculator</div>	<p>Taper calculator</p> <ul style="list-style-type: none"> ▶ Enter D1, D2, and L in the provided fields > The angle is automatically calculated > The taper is graphically displayed 	<p>Turning</p>

6.10.5 Auxiliary functions in Manual operation mode

Depending on the configured application mode, the following operating elements are available:

Operating element	Function
	<p>Reference marks For starting the reference mark search Further information: "Activating the reference mark search", Page 95</p>
	<p>Probing For probing the edge of a workpiece Further information: "Defining presets", Page 184</p>
	<p>Probing For finding the centerline of a workpiece Further information: "Defining presets", Page 184</p>
	<p>Probing For finding the center point of a circular feature (hole or cylinder) Further information: "Defining presets", Page 184</p>
	<p>Presets Setting presets Further information: "Presetting by probing (in the Turning application mode)", Page 145</p>
	<p>Tool data For tool setting (touch-off) Further information: "Setting the tool (in the Turning application mode)", Page 140</p>

6.11 OEM bar

The optional OEM bar allows you to control the configuration of the functions of the connected machine tool, independently of its configuration.



6.11.1 Operating elements of the OEM bar



The operating elements that are available on the OEM bar depend on the configuration of the device and of the connected machine tool.

Further information: "Configuring the OEM bar", Page 110

The **OEM bar** usually provides the following operating elements:

Operating element	Function
	Tapping the tab shows or hides the OEM bar
	Spindle speed Displays one or more values that have been predefined for the spindle speed of a connected NC-controlled machine tool Further information: "Configuring nominal values for the spindle speed", Page 111



6.11.2 Calling functions of the OEM bar



The operating elements that are available on the OEM bar depend on the configuration of the device and of the connected machine tool.

Further information: "Configuring the OEM bar", Page 110

The operating elements in the OEM bar allow you to control special functions (e.g., spindle functions).

Further information: "Configuring special functions", Page 113

Setting spindle speed



- ▶ Tap the **Spindle speed** field on the OEM bar
- > The product applies the predefined voltage value at which the spindle of the connected machine tool is brought to the selected rotational speed (with no load on the spindle)

Programming spindle speed



- ▶ Tap or long-press **+** or **-** to bring the spindle to the desired rotational speed



- ▶ Long-press the desired **Spindle speed** field on the OEM bar
- > The background color of the field is highlighted in green
- > The product applies the current spindle speed as the nominal value and displays it in the **Spindle speed** field

6.12 Messages and audio feedback

6.12.1 Messages

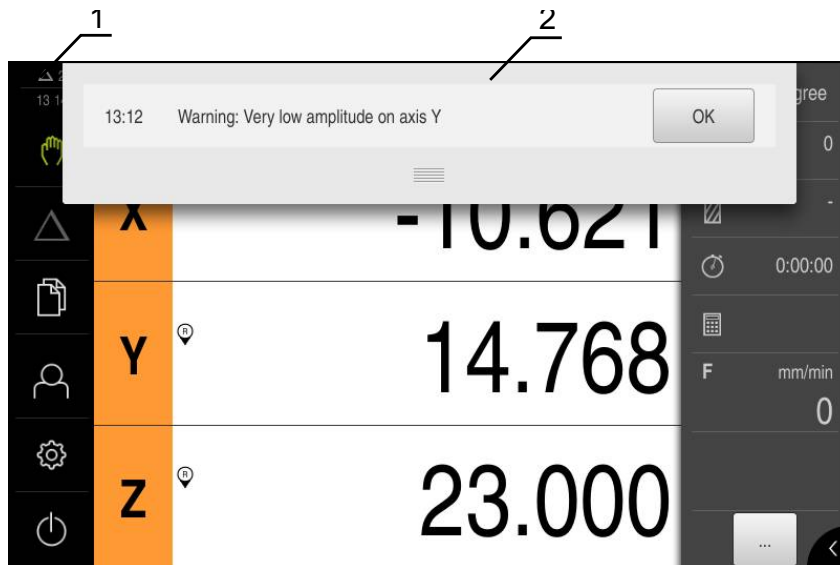

Figure 23: Display of messages in the workspace

- 1 Message display area
- 2 Message list

The messages that appear at the top of the workspace are triggered by, for example, operator errors or uncompleted processes.

The messages are displayed upon occurrence of the message cause or when you tap the **Messages** display area at the top left of the screen.

Viewing messages

- ▶ Tap **Messages**
- > The message list opens

Resizing the display area

- ▶ To resize the message display area, drag the **handle** up or down
- ▶ To close the display area, drag the **handle** up out of the screen
- > The number of unclosed messages is indicated in **Messages**

Closing messages

Depending on the content of the messages, you can close messages by means of the following operating elements:



- ▶ To close an informational message, tap **Close**
- > The message disappears

or

- ▶ To close a message that potentially has an effect on the application, tap **OK**
- > If applicable, the message will now be taken into account by the application
- > The message disappears

6.12.2 Wizard

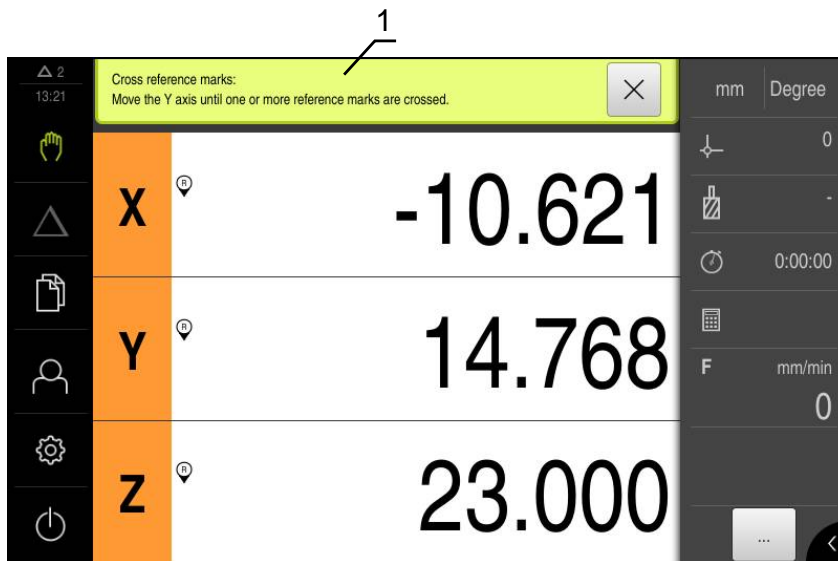







Figure 24: Support from the wizard for work steps

1 Wizard (example)

The wizard assists you in performing work steps or teach-in processes, and in executing programs.

The following operating elements provided by the wizard depend on the work step or process:

- 
 - ▶ To return to the last work step or repeat the process, tap **Undo**
- 
 - ▶ To confirm the displayed work step, tap **Confirm**
 - ▶ The wizard proceeds to the next step or concludes the process
- 
 - ▶ Tap **Next** to proceed to the next step
- 
 - ▶ Tap **Back** to return to the previous step
- 
 - ▶ Tap **Close** to close the wizard

6.12.3 Audio feedback

The product can provide audio feedback to indicate user actions, completed processes or malfunctions.

The available sounds are grouped into categories. The sounds differ within a category.

You can define the audio feedback settings in the **Settings** menu.

Further information: "Sounds", Page 231

7

Commissioning

7.1 Overview

This chapter contains all the information necessary for commissioning the product.

During commissioning, the machine manufacturer's commissioning engineer (**OEM**) configures the product for use on the specific machine tool.

The settings can be reset to the factory defaults.

Further information: "Reset", Page 261



Make sure that you have read and understood the "Basic Operation" chapter before carrying out the actions described below.

Further information: "Basic Operation", Page 57



The following steps must be performed only by qualified personnel.

Further information: "Personnel qualification", Page 27

7.2 Logging in for commissioning

User login

To commission the unit, the **OEM** user must log in.



- ▶ Tap **User login** in the main menu
- ▶ If required, log out the user who is currently logged in
- ▶ Select the **OEM** user
- ▶ Tap the **Password** input field
- ▶ Enter the password "oem"



If the password does not match the default password, ask a **Setup** user or **OEM** user for the assigned password.

If the password is no longer known, contact a HEIDENHAIN service agency.



- ▶ Confirm entry with **RET**
- ▶ Tap **Log in**
- > The user is logged in
- > The unit now opens the **Manual operation** operating mode



If the unit is configured with the **Turning** application mode and a **spindle axis S**, then you must define an upper limit for the spindle speed prior to a possible machining operation.

Further information: "Defining the upper limit for the spindle speed (in the Turning application mode)", Page 191



If the reference mark search after unit start is active, then all of the unit's functions will be disabled until the reference mark search has been successfully completed.

Further information: "Reference marks (Encoder)", Page 252

If the reference mark search is active on the unit, then a wizard will ask you to traverse the reference marks of the axes.

- ▶ After logging in, follow the instructions of the wizard
- > The Reference symbol stops blinking upon successful completion of the reference mark search

Further information: "Operating elements of the position display", Page 78

Further information: "Activating the reference mark search", Page 95

The default language for the user interface is English. You can switch the user interface to the desired language.



- ▶ Tap **Settings** in the main menu



- ▶ Tap **User**
- > The logged-in user is indicated by a check mark
- ▶ Select the logged-in user
- > The language selected for the user is indicated by a national flag in the **Language** drop-down list
- ▶ Select the flag for the desired language in the **Language** drop-down list
- > The user interface is displayed in the selected language

Changing the password

You must change the password to prevent unauthorized configuration.

The password is confidential and must not be disclosed to any other person.



- ▶ Tap **Settings** in the main menu



- ▶ Tap **User**
- > The logged-in user is indicated by a check mark
- ▶ Select the logged-in user
- ▶ Tap **Password**
- ▶ Enter the current password
- ▶ Confirm entry with **RET**
- ▶ Enter the new password and repeat it
- ▶ Confirm entry with **RET**
- ▶ Tap **OK**
- ▶ Close the message with **OK**
- > The new password is available the next time the user logs in

7.3 Steps for commissioning

NOTICE

Loss of or damage to configuration data!

If the product is disconnected from the power source while it is on, the configuration data can be lost or corrupted.

- ▶ Back up the configuration data and keep the backup for recovery purposes

7.3.1 Selecting the Application

During commissioning of the unit, you can choose between the **Milling** and **Turning** application modes. In its factory default setting, the unit is already set to the **Milling** application mode.



When you change the unit's application mode, then all of the axis settings will be reset.



- ▶ Tap **Settings** in the main menu



- ▶ Tap **Service**
- ▶ Open in the sequence
 - **OEM area**
 - **Settings**
- ▶ Select the desired application mode in the **Application** drop-down list:
 - **Milling: Milling** application mode
 - **Turning: Turning** application mode

7.3.2 Basic settings

Setting the date and time



- ▶ Tap **Settings** in the main menu



- ▶ Tap **General**
- ▶ Tap **Date and time**
- > The set values are displayed in the following format: Year, month, day, hour, minute
- ▶ To set the date and time in the middle line, drag the columns up or down
- ▶ Tap **Set** to confirm
- ▶ Select the desired format in the **Date format** list:
 - MM-DD-YYYY: Display as month, day, year
 - DD-MM-YYYY: Display as day, month, year
 - YYYY-MM-DD: Display as year, month, day

Further information: "Date and time", Page 233

Setting the units of measure

You can set various parameters to define the units of measure, rounding methods and decimal places.



- ▶ Tap **Settings** in the main menu



- ▶ Tap **General**
- ▶ Tap **Units**
- ▶ To set a unit of measure, tap the corresponding drop-down list and select the unit
- ▶ To set the rounding method, tap the corresponding drop-down list and select the rounding method
- ▶ To set the number of decimal places displayed, tap - or +

Further information: "Units", Page 234

7.3.3 Configuring the axes

Activating the reference mark search

The product uses the reference marks to reference the machine table to the machine. If the reference mark search has been activated, a wizard appears on startup of the product and asks the user to move the axes for the reference mark search.

Requirement: The installed encoders have reference marks that have been configured in the axis parameters.



The automatic reference mark search on startup of the product can be canceled depending on the configuration.

Further information: "Reference marks (Encoder)", Page 252



- ▶ Tap **Settings** in the main menu



- ▶ Tap **Axes**
 - ▶ Open in the sequence
 - **General settings**
 - **Reference marks**
 - ▶ Use the **ON/OFF** sliding switch to activate **Reference mark search after unit start**
 - The reference marks must be traversed every time the product is started
 - The functions of the product will only be available after the reference mark search has been completed
 - The Reference symbol stops blinking upon successful completion of the reference mark search
- Further information:** "Operating elements of the position display", Page 78

Configuring axis parameters for encoders

Before you start measuring, you need to configure the parameters of the connected encoders for the individual axes.

The parameters of HEIDENHAIN encoders, which are typically connected to the unit, can be found in the overview of typical encoders.

Further information: "Overview of typical encoders", Page 98



The configuration procedure is the same for each axis. The following section describes only the configuration of the X axis.



- ▶ Tap **Settings** in the main menu



- ▶ Tap **Axes**
- ▶ Tap **X** or, if applicable, **Not defined**
- ▶ If applicable, select the name of the axis in the **Axis name** drop-down list
- ▶ Tap **Axis type**
- ▶ Select **Axis typeLinear axis**



- ▶ In order to switch to the previous axis, tap **Back**
- ▶ Tap **Encoder**
- ▶ Specify the connection for the corresponding encoder in the **Encoder input** drop-down list:
 - **X1**
 - **X2**
 - **X3**
- ▶ Select the type of incremental signal in the **Incremental signal** drop-down list:
 - **1 Vpp**: Sinusoidal voltage signal
 - **11 µApp**: Sinusoidal current signal
- ▶ Select the encoder model in the **Encoder model** drop-down list:
 - **Linear encoder**: Linear axis
 - **Angle encoder**: Rotary axis
 - **Angle encoder as linear encoder**: Rotary axis is displayed as linear axis
- ▶ Depending on the selection, enter further parameters:
 - For a **Linear encoder**, enter the **Signal period** (refer to Page 98)
 - For an **Angle encoder**, enter the **Line count** (refer to Page 98)
 - For an **Angle encoder as linear encoder**, enter the **Line count** and the **Mechanical ratio**
- ▶ Confirm the entry with **RET**
- ▶ Tap **Reference marks**
- ▶ Select the reference mark in the **Reference mark** drop-down list:



- **None:** There is no reference mark
 - **One:** The encoder has one reference mark
 - **Coded:** The encoder has distance-coded reference marks
 - ▶ If the linear encoder has coded reference marks, enter the **Maximum traverse path** (refer to Page 98)
 - ▶ If the angle encoder has coded reference marks, enter the parameter for the **Nominal increment** (see Page 98)
 - ▶ Confirm the entry with **RET**
 - ▶ Use the **ON/OFF** sliding switch to activate or deactivate **Inversion of reference mark pulses**
 - ▶ Tap **Reference point displacement**
 - ▶ Use the **ON/OFF** sliding switch to activate or deactivate **Reference point displacement** (calculation of the offset between the reference mark and the machine zero point)
 - ▶ If activated, enter the offset value for **Reference point displacement**
 - ▶ Confirm the entry with **RET**
 - ▶ As an alternative, you can tap **Apply** in **Current position for reference point shift** in order to apply the current position as the offset value
 - ▶ In order to switch to the previous display, tap **Back** twice
 - ▶ In the **Analog filter frequency** drop-down list, select the frequency of the low-pass filter for suppressing high-frequency interference signals:
 - **33 kHz:** Interference frequencies above 33 kHz
 - **400 kHz:** Interference frequencies above 400 kHz
 - ▶ Use the **ON/OFF** sliding switch to activate or deactivate the **Terminating resistor**
-  The terminating resistor is automatically deactivated for incremental signals of the current signal type (11 μA_{PP})
- ▶ Select the type of error monitoring in the **Error monitor** drop-down list:
 - **Off:** Error monitoring not active
 - **Amplitude:** Error monitoring of signal amplitude
 - **Frequency:** Error monitoring of signal frequency
 - **Frequency & amplitude:** Error monitoring of signal amplitude and signal frequency
 - ▶ Select the desired counting direction in the **Counting direction** drop-down list:
 - **Positive:** The direction of traverse is in the counting direction of the encoder
 - **Negative:** The direction of traverse is opposite to the counting direction of the encoder

Further information: "Axes X, Y, Z, Zo", Page 248

Overview of typical encoders

The following overview lists the parameters of the HEIDENHAIN encoders that are typically connected to the product.



When connecting other encoders, refer to the encoder's documentation for the required parameters.

Linear encoders

Encoder series	Interface	Signal period	Reference mark	Maximum traverse path
LS 388C/688C	1 V _{PP}	20 μm	Coded	20 mm
LS 187/487	1 V _{PP}	20 μm	Coded	20 mm
LB 382C	1 V _{PP}	40 μm	Coded	80 mm

Angle encoders and rotary encoders

Encoder series	Interface	Line count/ output signals per revolution	Reference mark	Nominal increment
RON 285	1 V _{PP}	18000	One	-
RON 285C	1 V _{PP}	18000	Coded	20°
ROD 280	1 V _{PP}	18000	One	-
ROD 280C	1 V _{PP}	18000	Coded	20°
ROD 480	1 V _{PP}	1000 ... 5000	One	-
ROD 486	1 V _{PP}	1000 ... 5000	One	-
ERN 180	1 V _{PP}	1000 ... 5000	One	-
ERN 480	1 V _{PP}	1000 ... 5000	One	-



The formulae below enable you to calculate the nominal increment of the distance-coded reference marks with angle encoders:

Nominal increment = $360^\circ \div \text{number of reference marks} \times 2$

Nominal increment = $(360^\circ \times \text{nominal increment in signal periods}) \div \text{line count}$

Configuring the spindle axis

Depending on the configuration of the connected machine tool, you must configure the inputs and outputs and further parameters of the spindle axis prior to operation. If your machine tool uses a gear spindle, then you can also configure the corresponding gear stages.



- ▶ Tap **Settings** in the main menu



- ▶ Tap **Axes**
- ▶ Tap **S** or, if applicable, **Not defined**
- ▶ Tap **Axis type**
- ▶ Select the **Axis type**:

- **Spindle**
- **Gear spindle**



- ▶ To switch to the previous display, tap **Back**
- ▶ If applicable, select the axis name **S** for the axis in the **Axis name** drop-down list.

- ▶ Tap **Outputs**
- ▶ Enter the parameters for the analog outputs used (refer to Page 256)



- ▶ To switch to the previous display, tap **Back**
- ▶ Tap **Inputs**
- ▶ Enter the parameters for the digital and analog inputs used (refer to Page 256)



- ▶ To switch to the previous display, tap **Back**
- ▶ If, under **Axis type**, the **Gear spindle** option is selected, then tap **Gear stages**



- ▶ Tap **Add**
- ▶ Tap the gear stages and enter the parameters for the gear stages (refer to Page 258)



- ▶ To switch to the previous display, tap **Back**
- ▶ If, under **Axis type**, the **Gear spindle** option is selected, then activate or deactivate **Gear stage selection through an external signal** using the **ON/OFF** slide switch
- ▶ Enter the corresponding values in the fields **Start-up time for upper spindle speed range** and **Start-up time for lower spindle speed range**
- ▶ If, under **Axis type**, the **Spindle** option is selected, then enter the corresponding values in the fields **Break point of characteristic curve for start-up times** and **Minimum spindle speed**
- ▶ If applicable, enter the corresponding values in the fields **Maximum spindle speed for oriented spindle stop** and **Maximum spindle speed for thread cutting**

Further information: "Spindle axis S", Page 254

Minimum configuration for outputs and inputs

For operating a spindle, you must assign at least one analog output to the spindle axis. A spindle axis can be started and stopped either via the **M functions** M3/M4 or manually.

If no M3/M4 **M functions** are available, then the spindle can be operated only manually. To do so, you must configure the parameters of the **Spindle start** and **Spindle stop** digital inputs. This results in the minimum configuration for the outputs and inputs:

Control of the spindle axis	Analog output	Inputs	
		Spindle start	Spindle stop
Manually	Assigned	Assigned	Assigned
M functions M3/M4	Assigned	Not connected	Not connected

Performing error compensation

Mechanical influences such as guideway errors, tilting in the end positions, tolerances of the mounting surface or poor mounting (Abbe error) may lead to measuring errors. Error compensation enables the device to automatically compensate for systematic measuring errors during machining of the workpieces. One or more compensation factors can be defined by comparing nominal and actual values.

A distinction is made between the following methods:

- Linear error compensation (LEC): The compensation factor is calculated based on the specified length of a calibration standard (nominal length) and the actual distance traversed (actual length). The compensation factor is applied linearly to the entire measuring range.
- Segmented linear error compensation (SLEC): The axis is divided into multiple segments with the help of a maximum of 200 supporting points. A distinct compensation factor is defined and applied for every segment.

NOTICE

Subsequent changes to the encoder settings can cause measuring errors

If encoder settings such as encoder input, encoder type, signal period, or reference marks are changed, then previously determined compensation factors may no longer apply.

- ▶ Reconfigure the error compensation if encoder settings are changed.



For all methods, the actual error curve must be exactly measured (e.g., with the help of a comparator measuring device or calibration standard).



Linear error compensation and segmented linear error compensation cannot be combined with each other.

Configuring linear error compensation (LEC)

With linear error compensation (LEC) the product applies a compensation factor that is calculated from the specified length of a reference standard (nominal length) and the actual traverse path (actual length). The compensation factor is applied to the complete measuring range.



- ▶ Tap **Settings** in the main menu



- ▶ Tap **Axes**
- ▶ Select the axis
- ▶ Open in the sequence
 - **Error compensation**
 - **Linear error compensation (LEC)**
- ▶ Enter the length of the reference standard (nominal length)
- ▶ Confirm the entry with **RET**
- ▶ Enter the length of the actual traverse path determined by measure (actual length)
- ▶ Confirm the entry with **RET**
- ▶ Activate **Compensation** with the **ON/OFF** sliding switch



You can also use **Linear error compensation (LEC)** for angle encoders if the rotation angle is less than 360°.

Further information: "Linear error compensation (LEC)", Page 253

Configuring segmented linear error compensation (SLEC)

For a segmented linear error compensation (SLEC), you divide the axis into short segments by defining up to 200 supporting points. The deviations between the actual distance traversed and the segment length in the individual segments determine the compensation values that compensate the mechanical influences acting on the axis.



- ▶ Tap **Settings** in the main menu



- ▶ Tap **Axes**
- ▶ Select the axis
- ▶ Open in the sequence
 - **Error compensation**
 - **Segmented linear error compensation (SLEC)**
- ▶ Deactivate **Compensation** with the **ON/OFF** sliding switch
- ▶ Tap **Create table of supporting points**
- ▶ Tap **+** or **-** to set the desired **Number of supporting points** (max. 200)
- ▶ Enter the desired **Spacing of the supporting points**
- ▶ Confirm the entry with **RET**
- ▶ Enter the **Start point**
- ▶ Confirm the entry with **RET**
- ▶ Tap **Create** to create the table of supporting points
- > The table of supporting points is created
- > The table lists the **supporting point positions (P)** and the **compensation values (D)** of the individual segments
- ▶ Enter the compensation value (D) **"0.0"** for supporting point **0**
- ▶ Confirm the entry with **RET**
- ▶ Enter the measured compensation value into the **compensation value (D)** input field for each supporting point created
- ▶ Confirm the entry with **RET**



- ▶ To switch to the previous display, tap **Back** twice
- ▶ Activate **Compensation** with the **ON/OFF** sliding switch
- > The error compensation for the axis is applied

Further information: "Segmented linear error compensation (SLEC)", Page 253

Adjusting an existing table of supporting points

After a table of supporting points for segmented linear error compensation has been created, this table can then be modified as needed.



- ▶ Tap **Settings** in the main menu



- ▶ Tap **Axes**
- ▶ Select the axis
- ▶ Open in the sequence
 - **Error compensation**
 - **Segmented linear error compensation (SLEC)**
- ▶ Deactivate **Compensation** with the **ON/OFF** sliding switch
- ▶ Tap **Table of supporting points**
- > The table lists the **supporting point positions (P)** and the **compensation values (D)** of the individual segments
- ▶ Adjust the **compensation value (D)** for the supporting points
- ▶ Confirm the entries with **RET**



- ▶ To switch to the previous display, tap **Back**
- ▶ Activate **Compensation** with the **ON/OFF** sliding switch
- > The adjusted error compensation for the axis is applied

Further information: "Segmented linear error compensation (SLEC)", Page 253

7.3.4 Using M functions



The following information applies to units with ID number 1089178-xx only to a limited extent.

Depending on the configuration of the machine tool, you can also use M functions (machine functions) for machining operations. You can use M functions to influence the following factors:

- functions on the machine tool, such as switching the spindle rotation and coolant on and off
- In the **Milling** application mode: the contouring behavior of the tool

The product differentiates between standard M functions and the manufacturer-specific M functions.

Standard M functions

The product supports the following standard M functions (oriented to DIN 66025/ISO 6983):

Code	Description
M3	Spindle rotation in clockwise direction
M4	Spindle rotation in counterclockwise direction
M5	Spindle STOP
M8	Coolant ON
M9	Coolant OFF

These M functions are independent of the machine; some M functions however depend on the machine tool configuration (e.g. spindle functions).

Manufacturer-specific M functions



The manufacturer-specific M functions M100 to M120 are only available if the connected output has been previously configured.

Further information: "Configuring M functions", Page 247

The product also supports manufacturer-specific M functions with the following characteristics:

- Number range definable from M100 to M120
- Function depends on the machine manufacturer
- Use in the button of the OEM bar

Further information: "Configuring the OEM bar", Page 110

7.3.5 Configuring a touch probe (in the Milling application mode)



The following information applies only to the **Milling** application mode.

You can use probing functions to set presets with a HEIDENHAIN KT 130 Edge Finder. The stylus of the edge finder can be additionally fitted with a ruby ball tip. In order to use the KT 130 edge finder, you need to configure the relevant parameters. The parameters are taken into account by the probing functions.



- ▶ Tap **Settings** in the main menu



- ▶ Tap **Sensors**
- ▶ Tap **Touch probe**
- ▶ Select the **KT 130** model for edge detection in the **Touch probe** drop-down list
- ▶ Use the **ON/OFF** sliding switch to activate or deactivate the **Always use touch probe for probing** option as needed
- ▶ Enter the length difference of the edge finder into the **Length** field
- ▶ Confirm the entry with **RET**
- ▶ Enter the stylus diameter of the edge finder into the **Diameter** field
- ▶ Confirm the entry with **RET**

7.4 OEM area

In the **OEM area**, commissioning engineers can customize the product in various ways:

- **Documentation:** Adding the OEM documentation, e.g. service information
- **Startup screen:** Defining a startup screen with the OEM's company logo
- **OEM bar:** Configuring an OEM bar with specific functions
- **Settings:** Selecting the application and adjusting the display elements
- **Screenshots:** Configuring the unit for screenshots with the program ScreenshotClient

7.4.1 Adding documentation

You can store and display the product's documentation right on the product.



Only documents in the *.pdf file format can be added as a documentation. The product does not display documents provided in other file formats.



- ▶ Tap **Settings** in the main menu



- ▶ Tap **Service**
- ▶ Open in the sequence
 - **OEM area**
 - **Documentation**
 - **Add OEM service info**
- ▶ If required, connect a USB mass storage device (FAT32 format) to a USB port of the product
- ▶ To navigate to the desired file, tap the location where the file is stored



If you have accidentally tapped the wrong folder, you can return to the previous folder.

- ▶ Tap the file name that is displayed above the list

- ▶ Navigate to the folder containing the file
- ▶ Tap the file name
- ▶ Tap **Select**
- ▶ The file is copied to the unit's **Service info** area
Further information: "Service info", Page 235
- ▶ Confirm the successful transfer with **OK**

Further information: "Documentation", Page 269

Safely removing a USB mass storage device



- ▶ Tap **File management** in the main menu
- ▶ Navigate to the list of storage locations



- ▶ Tap **Safely remove**
- > The message **The storage medium can be removed now.** appears
- ▶ Disconnect the USB mass storage device

7.4.2 Adding a startup screen

You can define an OEM-specific startup screen, e.g. the company name or logo, which will be displayed when the product is switched on. An image file with the following properties needs to be stored on the product for this purpose:

- File format: PNG or JPG
- Resolution: 96 dpi
- Image format: 16:10 (other formats will be scaled proportionally)
- Image size: Max. 1280 x 800 px

Adding a startup screen



- ▶ Tap **Settings** in the main menu



- ▶ Tap **Service**
- ▶ Open in the sequence
 - **OEM area**
 - **Startup screen**
 - **Add startup screen**
- ▶ If required, connect a USB mass storage device (FAT32 format) to a USB port of the product
- ▶ To navigate to the desired file, tap the location where the file is stored



If you have accidentally tapped the wrong folder, you can return to the previous folder.

- ▶ Tap the file name that is displayed above the list

- ▶ Navigate to the folder containing the file
- ▶ Tap the file name
- ▶ Tap **Select**
- > The image is copied to the product and displayed as the startup screen the next time the product is started
- ▶ Confirm the successful transfer with **OK**

Safely removing a USB mass storage device



- ▶ Tap **File management** in the main menu
- ▶ Navigate to the list of storage locations
- ▶ Tap **Safely remove**
- ▶ The message **The storage medium can be removed now.** appears
- ▶ Disconnect the USB mass storage device

7.4.3 Generating a Text database

You can show specific messages for various work processes on the product's screen. To do so, generate an "*.xml" text database file on a computer. Then you import the XML file by means of a USB mass storage device (FAT32 format) and save it, for example, in the "OEM" folder.

The XML file must have the following characteristics:

- File coding: UTF-8
- File type: *.xml

The figure below shows the correct structure of the XML file:

```

1  <?xml version="1.0" encoding="UTF-8"?>
2  <source version="1">
3    <entry id="ID_OEM_EMERGENCY_STOP">
4      <text lang="de">Der Not-Aus ist aktiv.</text>
5      <text lang="cs">Nouzové zastavení je aktivní.</text>
6      <text lang="en">The emergency stop is active.</text>
7      <text lang="fr">L&apos;arrêt d&apos;urgence est actif.</text>
8      <text lang="it">L&apos;arresto d&apos;emergenza è attivo.</text>
9      <text lang="es">La parada de emergencia está activa.</text>
10     <text lang="ja">緊急停止がアクティブです.</text>
11     <text lang="pl">Wyłączenie awaryjne jest aktywne.</text>
12     <text lang="pt">O desligamento de emergência está ativo.</text>
13     <text lang="ru">Активный аварийный останов.</text>
14     <text lang="zh">急停激活.</text>
15     <text lang="zh-tw">緊急停止啟動.</text>
16     <text lang="ko">비상 정지가 작동 중입니다.</text>
17     <text lang="tr">Acil kapatma etkin.</text>
18     <text lang="nl">De noodstop is actief.</text>
19   </entry>
20   <entry id="ID_OEM_CONTROL_VOLTAGE">
21     <text lang="de">Es liegt keine Steuerspannung an.</text>
22     <text lang="cs">Není použito žádné řídicí napětí.</text>
23     <text lang="en">No machine control voltage is being applied.</text>
24     <text lang="fr">Aucune tension de commande n&apos;est appliquée.</text>
25     <text lang="it">Non è applicata alcuna tensione di comando.</text>
26     <text lang="es">No está aplicada la tensión de control.</text>
27     <text lang="ja">御電圧は適用されていません.</text>
28     <text lang="pl">Brak zasilania sterowania.</text>
29     <text lang="pt">Não existe tensão de comando.</text>
30     <text lang="ru">Управляющее напряжение отсутствует.</text>
31     <text lang="zh">无控制电压.</text>
32     <text lang="zh-tw">並無供應控制電壓.</text>
33     <text lang="ko">공급된 제어 전압이 없습니다.</text>
34     <text lang="tr">Kumanda gerilimi mevcut değil.</text>
35     <text lang="nl">Er is geen sprake van stuurspanning.</text>
36   </entry>
37 </source>

```

Figure 25: XML file as text database

Selecting the Text database



- ▶ Tap **Settings** in the main menu.



- ▶ Tap **Service**
- ▶ Open in the sequence
 - **OEM area**
 - **Settings**
 - **Text database**
- ▶ To navigate to the desired file, tap the location where the file is stored



If you have accidentally tapped the wrong folder, you can return to the previous folder.

- ▶ Tap the file name that is displayed above the list

- ▶ Navigate to the folder containing the XML file
- ▶ Tap the file name
- ▶ Tap **Select**
- ▶ Confirm the successful transfer with **OK**
- > You have now successfully imported the **Text database**

Further information: "Text database", Page 268

7.4.4 Configuring the OEM bar

You can configure the appearance and the menu items of the OEM bar.



If you configure more menu entries than can be shown in the **OEM bar**, then you can scroll the **OEM bar** vertically.

Showing or hiding the OEM bar



- ▶ Tap **Settings** in the main menu



- ▶ Tap **Service**
- ▶ Open in the sequence
 - **OEM area**
 - **OEM bar**
- ▶ Activate or deactivate **Show bar** with the **ON/OFF** sliding switch

Configuring the OEM logo

You can display an OEM-specific company logo on the OEM bar. By tapping the OEM logo, you can optionally open a PDF file of the OEM documentation.

Configuring an OEM logo



- ▶ Tap **Settings** in the main menu



- ▶ Tap **Service**
- ▶ Open in the sequence
 - **OEM area**
 - **OEM bar**
 - **Bar items**



- ▶ Tap **Add**
- ▶ Tap the **Description** input field
- ▶ Enter a description for the menu item
- ▶ Confirm the entry with **RET**
- ▶ Tap **Logo** in the **Type** drop-down list
- ▶ Tap **Select logo** to choose a stored image file
- ▶ If required, select a new image file with **Upload image file**
Further information: "Logo OEM bar item", Page 264
- ▶ Navigate to the folder containing the image file, and select the file
- ▶ Tap **Select**
- ▶ Select the desired option in the **Link to documentation** drop-down list

Configuring nominal values for the spindle speed

On the OEM bar, you can define menu items that control the spindle speeds depending on the configuration of the machine tool.



You can overwrite configured spindle speeds with the value of the currently set speed of the spindle axis by holding down a **Spindle speed** field.

Further information: "Calling functions of the OEM bar", Page 87

Configuring nominal values for the spindle speed



- ▶ Tap **Settings** in the main menu



- ▶ Tap **Service**
- ▶ Open in the sequence
 - **OEM area**
 - **OEM bar**
 - **Bar items**



- ▶ Tap **Add**
- ▶ Tap the **Description** input field
- ▶ Enter a description for the menu item
- ▶ Confirm the entry with **RET**
- ▶ Tap **Spindle speed** in the **Type** drop-down list
- ▶ Tap the name of the spindle in the **Spindle** drop-down list
- ▶ Enter the desired nominal value into the **Spindle speed** input field

Configuring M functions

 The following information applies to units with ID number 1089178-xx only to a limited extent.

On the OEM bar, you can define menu items that control the use of M functions depending on the configuration of the machine tool.

 The manufacturer-specific M functions M100 to M120 are only available if the connected output has been previously configured.

Further information: "Configuring M functions", Page 247

Configuring M functions



- ▶ Tap **Settings** in the main menu.



- ▶ Tap **Service**
- ▶ Open in the sequence
 - **OEM area**
 - **OEM bar**
 - **Bar items**



- ▶ Tap **Add**
- ▶ Tap the **Description** input field
- ▶ Enter a description for the menu item
- ▶ Confirm the entry with **RET**
- ▶ Tap **M function** in the **Type** drop-down list
- ▶ Enter the number into the **Number of the M function** input field:
 - **100.T ... 120.T (TOGGLE** switches between the states when tapped)
 - **100.P ... 120.P (PULSE** outputs a short pulse when activated; it can be extended by setting the **Pulse time**)
- ▶ Confirm the entry with **RET**
- ▶ For every M function, you can also define corresponding images for displaying the status using **Select image for active function** and **Select image for inactive function**

Further information: "M function OEM bar item", Page 265

Configuring special functions



The following information applies only to units with ID number 1089179-xx.

On the OEM bar, you can define menu items that control special functions of the connected machine tool.



The available functions depend on the configuration of the device and of the connected machine tool.

Configuring special functions



- ▶ Tap **Settings** in the main menu



- ▶ Tap **Service**
- ▶ Open in the sequence
 - **OEM area**
 - **OEM bar**
 - **Bar items**



- ▶ Tap **Add**
- ▶ Tap the **Description** input field
- ▶ Enter a description for the menu item
- ▶ Confirm the entry with **RET**
- ▶ Tap **Special functions** in the **Type** drop-down list
- ▶ Tap the desired special function in the **Function** drop-down list
 - **Thread cutting**
 - **Spindle direction**
 - **Coolant**
 - **Coolant during spindle operation**
 - **Clamp axes**: this function is not supported by units of this series
 - **Zero tool axis**
- ▶ For each special function, you can also define corresponding images for displaying the status using **Select image for active function** and **Select image for inactive function**
Further information: "Special functions OEM bar item", Page 266

Configuring documents

On the OEM bar, you can define menu items that display additional documents. The file to be displayed needs to be stored in PDF format on the product for this purpose.

Configuring documents



- ▶ Tap **Settings** in the main menu



- ▶ Tap **Service**
- ▶ Open in the sequence
 - **OEM area**
 - **OEM bar**
 - **Bar items**



- ▶ Tap **Add**
- ▶ Tap the **Description** input field
- ▶ Enter a description for the menu item
- ▶ Confirm the entry with **RET**
- ▶ Tap **Document** in the **Type** drop-down list
- ▶ Tap **Select a document** to choose a stored document
- ▶ Tap **Select image for display** to select the image file you want to display
- ▶ Navigate to the folder containing the image file, and select the file
- ▶ Tap **Select**

Deleting menu items

You can delete individual menu items from the OEM bar.

Deleting menu items



- ▶ Tap **Settings** in the main menu



- ▶ Tap **Service**
- ▶ Open in the sequence
 - **OEM area**
 - **OEM bar**
 - **Bar items**
- ▶ Tap the desired menu item
- ▶ Tap **Remove bar entry**
- ▶ Tap **OK** to confirm deletion
- > The menu item is deleted from the OEM bar

7.4.5 Adjusting the display

You can adjust the override display in the **Manual operation** and **MDI** menus. You can also define the layout of the screen keyboard.

Defining the keyboard design



- ▶ Tap **Settings** in the main menu



- ▶ Tap **Service**
- ▶ Open in the sequence
 - **OEM area**
 - **Settings**
- ▶ Select the desired layout for the screen keyboard in the **Keyboard theme** drop-down list

7.4.6 Back up OEM specific folders and files

The OEM-specific directories and the product's files can be backed up as a file so that they are available after a reset to the factory default settings has been performed or for installation on multiple units.



- ▶ Tap **Settings** in the main menu.



- ▶ Tap **Service**
- ▶ Open in the sequence
 - **OEM area**
 - **Back up and restore**
 - **Back up OEM specific folders and files**
 - **Save as ZIP**
- ▶ If required, connect a USB mass storage device (FAT32 format) to a USB port of the product
- ▶ Select the folder to which you want to copy the data
- ▶ Specify a name for the file, e.g. "<yyyy-mm-dd>_OEM_config"
- ▶ Confirm the entry with **RET**
- ▶ Tap **Save as**
- ▶ Tap **OK** to confirm the successful backup of the data
- > The data were saved

Safely removing a USB mass storage device



- ▶ Tap **File management** in the main menu
- ▶ Navigate to the list of storage locations



- ▶ Tap **Safely remove**
- > The message **The storage medium can be removed now.** appears
- ▶ Disconnect the USB mass storage device

7.4.7 Configuring the unit for screenshots

ScreenshotClient

With the ScreenshotClient PC software, you can use a computer to take screenshots of the active screen of the unit.

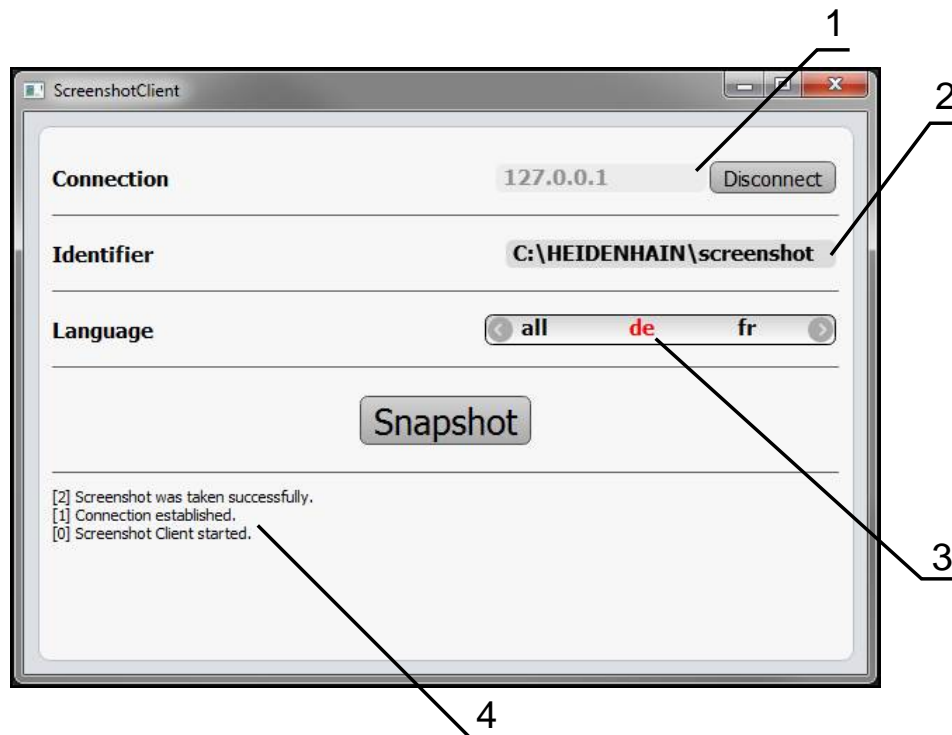

Figure 26: The ScreenshotClient user interface

- 1 Connection status
- 2 File path and file name
- 3 Language selection
- 4 Status messages

i ScreenshotClient is included in the standard installation of **ND 7000 Demo**.

m For a detailed description, please refer to the **ND 7000 Demo User's Manual** contained in the download folder of the software.

Further information: "Demo software for the product", Page 16

Activating remote access for screenshots

To connect ScreenshotClient with the product via the computer you need to activate **Remote access for screenshots** on the product.



- ▶ Tap **Settings** in the main menu



- ▶ Tap **Service**
- ▶ Tap **OEM area**
- ▶ Activate **Remote access for screenshots** with the **ON/OFF** sliding switch

Further information: "OEM area", Page 262

7.5 Back up settings

The settings of the product can be backed up as a file to make it available after a reset to the factory default settings or for installation on multiple products.



- ▶ Tap **Settings** in the main menu



- ▶ Tap **Service**
- ▶ Open in the sequence
 - **Back up and restore**
 - **Back up settings**

Complete backup

During a complete backup of the configuration, all settings of the product are backed up.

- ▶ Tap **Complete backup**
- ▶ If required, connect a USB mass storage device (FAT32 format) to a USB port of the product
- ▶ Select the folder to which you want to copy the configuration data
- ▶ Specify a name for the configuration data, e.g. "<yyyymmdd>_config"
- ▶ Confirm the entry with **RET**
- ▶ Tap **Save as**
- ▶ Tap **OK** to confirm the successful backup of the configuration
- > The configuration file was backed up

Further information: "Back up and restore", Page 260

Safely removing a USB mass storage device



- ▶ Tap **File management** in the main menu
- ▶ Navigate to the list of storage locations



- ▶ Tap **Safely remove**
- > The message **The storage medium can be removed now.** appears
- ▶ Disconnect the USB mass storage device

7.6 Back up user files

The user files of the product can be backed up as a file to make it available after a reset to the factory default state or for installation on multiple products.

Performing back up

The user files can be backed up as a ZIP file on a USB mass storage device or connected network drive.



- ▶ Tap **Settings** in the main menu



- ▶ Tap **Service**
- ▶ Open in the sequence
 - **Back up and restore**
 - **Back up user files**
- ▶ Tap **Save as ZIP**
- ▶ If required, connect a USB mass storage device (FAT32 format) to a USB port of the product
- ▶ Select the folder to which you want to copy the ZIP file
- ▶ Specify a name for the ZIP file, e.g. "<yyyy-mm-dd>_config"
- ▶ Confirm the entry with **RET**
- ▶ Tap **Save as**
- ▶ Tap **OK** to confirm successful backup of the user files
- > The user files were backed-up.

Further information: "Back up and restore", Page 260

Safely removing a USB mass storage device



- ▶ Tap **File management** in the main menu
- ▶ Navigate to the list of storage locations
- ▶ Tap **Safely remove**



- > The message **The storage medium can be removed now.** appears
- ▶ Disconnect the USB mass storage device

8

Setup

8.1 Overview

This chapter contains all the information necessary for setting up the product.

During setup, the **(Setup)** engineer configures the unit for use on machine tools in the respective application. This includes, for example, setting up operators as well as creating preset tables and tool tables.



Make sure that you have read and understood the "Basic Operation" chapter before carrying out the actions described below.

Further information: "Basic Operation", Page 57



The following steps must be performed only by qualified personnel.

Further information: "Personnel qualification", Page 27

8.2 Logging in for setup

User login

To set up the unit, the **Setup** user must log in.



- ▶ Tap **User login** in the main menu
- ▶ If required, log out the user who is currently logged in
- ▶ Select the **Setup** user
- ▶ Tap the **Password** input field
- ▶ Enter the password "setup"



If the password does not match the default password, ask a **Setup** user or **OEM** user for the assigned password.

If the password is no longer known, contact a HEIDENHAIN service agency.

- ▶ Confirm entry with **RET**
- ▶ Tap **Log in**



If the unit is configured with the **Turning** application mode and a **spindle axis S**, then you must define an upper limit for the spindle speed prior to a possible machining operation.

Further information: "Defining the upper limit for the spindle speed (in the Turning application mode)", Page 191



If the reference mark search after unit start is active, then all of the unit's functions will be disabled until the reference mark search has been successfully completed.

Further information: "Reference marks (Encoder)", Page 252

If the reference mark search is active on the unit, then a wizard will ask you to traverse the reference marks of the axes.

- ▶ After logging in, follow the instructions of the wizard
- > The Reference symbol stops blinking upon successful completion of the reference mark search

Further information: "Operating elements of the position display", Page 78

Further information: "Activating the reference mark search", Page 95

Changing the password

You must change the password to prevent unauthorized configuration.

The password is confidential and must not be disclosed to any other person.



- ▶ Tap **Settings** in the main menu



- ▶ Tap **User**
 - > The logged-in user is indicated by a check mark
 - ▶ Select the logged-in user
 - ▶ Tap **Password**
 - ▶ Enter the current password
 - ▶ Confirm entry with **RET**
 - ▶ Enter the new password and repeat it
 - ▶ Confirm entry with **RET**
 - ▶ Tap **OK**
 - ▶ Close the message with **OK**
 - > The new password is available the next time the user logs in

8.3 Single steps for setup

8.3.1 Basic settings



The commissioning engineer (**OEM**) may have already carried out several basic settings.

Setting the date and time



- ▶ Tap **Settings** in the main menu



- ▶ Tap **General**
- ▶ Tap **Date and time**
- The set values are displayed in the following format: Year, month, day, hour, minute
- ▶ To set the date and time in the middle line, drag the columns up or down
- ▶ Tap **Set** to confirm
- ▶ Select the desired format in the **Date format** list:
 - MM-DD-YYYY: Display as month, day, year
 - DD-MM-YYYY: Display as day, month, year
 - YYYY-MM-DD: Display as year, month, day

Further information: "Date and time", Page 233

Setting the units of measure

You can set various parameters to define the units of measure, rounding methods and decimal places.



- ▶ Tap **Settings** in the main menu



- ▶ Tap **General**
- ▶ Tap **Units**
- ▶ To set a unit of measure, tap the corresponding drop-down list and select the unit
- ▶ To set the rounding method, tap the corresponding drop-down list and select the rounding method
- ▶ To set the number of decimal places displayed, tap - or +

Further information: "Units", Page 234

Entering and configuring users

The following user types, which have different rights, are defined in the product's factory default settings:

- **OEM**
- **Setup**
- **Operator**

Creating a user and password

You can create new **Operator** users. You can use any characters for the user ID and the password. These entries are case-sensitive.

Requirement: An **OEM** or **Setup** user is logged in.

 It is not possible to create new **OEM** or **Setup**-type users.



- ▶ Tap **Settings** in the main menu



- ▶ Tap **User**



- ▶ Tap **Add**
- ▶ Tap the **User ID** input field

 The **User ID** is displayed for user selection, e.g. at the login prompt.
The **User ID** cannot be changed later.

- ▶ Enter the user ID
- ▶ Confirm the entry with **RET**
- ▶ Tap the **Name** input field
- ▶ Enter the name of the new user
- ▶ Confirm the entry with **RET**
- ▶ Tap the **Password** input field
- ▶ Enter the new password and repeat it
- ▶ Confirm the entry with **RET**

 You can show the contents of the password fields in plain text and hide them again.

- ▶ Use the **ON/OFF** sliding switch to show or hide the contents

- ▶ Tap **OK**
- > A message appears
- ▶ Close the message with **OK**
- > The user is created with the basic data. The user can then further edit the data himself later

Configuring the user

After creating a new **Operator**-type user, you can add or edit the following user data:

- Name
- First name
- Department
- Password
- Language
- Auto login



If automatic user login is active for one or more users, the last user who logged in is automatically logged in when the product is switched on. Neither the user ID nor the password needs to be entered.



- ▶ Tap **Settings** in the main menu



- ▶ Tap **User**
- ▶ Select the user
- ▶ Tap the input field whose contents you want to edit: **Name**, **First name**, **Department**
- ▶ Edit the contents and confirm your changes with **RET**
- ▶ To change the password, tap **Password**
- > The **Change password** dialog appears
- ▶ When changing the password of the logged-in user, enter the current password
- ▶ Confirm the entry with **RET**
- ▶ Enter the new password and repeat it
- ▶ Confirm the entries with **RET**
- ▶ Tap **OK**
- > A message appears
- ▶ Close the message with **OK**
- ▶ To change the language, select the flag for the desired language in the **Language** drop-down list
- ▶ To activate or deactivate **Auto login**, use the **ON/OFF** sliding switch

Deleting users

You can remove **Operator**-type users that are no longer needed.



OEM and **Setup**-type users cannot be deleted.

Requirement: A user of **OEM** or **Setup**-type is logged in.



- ▶ Tap **Settings** in the main menu



- ▶ Tap **User**
- ▶ Tap the user you want to delete
- ▶ Tap **Remove user account**
- ▶ Enter the password of the authorized user (**OEM** or **Setup**)
- ▶ Tap **OK**
- > The user is deleted

Adding the Operating Instructions

The product provides the possibility to upload the corresponding Operating Instructions in the desired language. You can copy the Operating Instructions from the supplied USB mass storage device to the product.

The most recent version of the Operating Instructions is also available at www.heidenhain.de.

Requirement: The Operating Instructions are available as a PDF file.



- ▶ Tap **Settings** in the main menu



- ▶ Tap **Service**
- ▶ Open in the sequence
 - **Documentation**
 - **Add Operating Instructions**
- ▶ If required, connect a USB mass storage device (FAT32 format) to a USB port of the product
- ▶ Navigate to the folder containing the new Operating Instructions



If you have accidentally tapped the wrong folder, you can return to the previous folder.

- ▶ Tap the file name that is displayed above the list

- ▶ Select file
- ▶ Tap **Select**
- > The Operating Instructions are copied to the product
- > Any existing Operating Instructions will be overwritten
- ▶ Confirm successful transfer with **OK**
- > The Operating Instructions can be opened and displayed on the product

Configuring the network

Network settings



Contact your network administrator for the correct network settings for configuring the product.

Requirement: The unit is connected to a network.

Further information: "Connecting a network peripheral", Page 54



- ▶ Tap **Settings** in the main menu



- ▶ Tap **Interfaces**
- ▶ Tap **Network**
- ▶ Tap the **X116** interface
 - > The MAC address is detected automatically
 - ▶ Depending on the network environment, activate or deactivate **DHCP** using the **ON/OFF** sliding switch
 - > If DHCP is active, the network settings are obtained automatically as soon as the IP address is assigned
 - ▶ If the DHCP is not active, enter the **IPv4 address, IPv4 subnet mask** and **IPv4 standard gateway**
 - ▶ Confirm the entries with **RET**
 - ▶ Depending on the network environment, activate or deactivate **IPv6 SLAAC** with the **ON/OFF** sliding switch
 - > If IPv6 SLAAC is active, the network settings are obtained automatically as soon as the IP address is assigned
 - ▶ If IPv6 SLAAC is not active, enter the **IPv6 address, IPv6 subnet prefix length** and **IPv6 standard gateway**
 - ▶ Confirm the entries with **RET**
 - ▶ Enter the **Preferred DNS server** and, if required, the **Alternative DNS server**
 - ▶ Confirm the entries with **RET**
 - > The configuration of the network connection is applied

Further information: "Network", Page 237

Network drive

You will need the following data for configuring the network drive:

- **Name**
- **Server IP address or host name**
- **Shared folder**
- **User name**
- **Password**
- **Network drive options**



Contact your network administrator for the correct network settings for configuring the product.

Requirement: The product is connected to a network and a network drive is available.

Further information: "Connecting a network peripheral", Page 54



- ▶ Tap **Settings** in the main menu



- ▶ Tap **Interfaces**
- ▶ Tap **Network drive**
- ▶ Enter the network drive details
- ▶ Confirm the entries with **RET**
- ▶ Use the **ON/OFF** sliding switch to activate or deactivate **Show password**
- ▶ If required, select **Network drive options**
 - Select **Authentication** for encrypting the password in the network
 - Configure the **Mount options**
 - Tap **OK**
- ▶ Tap **Mount**
- ▶ The connection to the network drive is established

Further information: "Network drive", Page 238

Configuring the printer

The product can print measurement reports and stored PDF files with a printer connected via USB or the network. The product supports several printer models from various manufacturers. See the product area at www.heidenhain.de for a complete list of supported printers.

If this list contains the used printer, the appropriate driver is available on the product and you can directly configure the printer. If this is not the case, you will need a printer-specific PPD file.

Further information: "Finding PPD files", Page 134

Adding a USB printer

Requirement: A USB printer is connected to the product.

Further information: "Connecting a printer", Page 53



- ▶ Tap **Settings** in the main menu



- ▶ Tap **General**

- ▶ Tap **Printers**

- > If no default printer has been set up yet, a message appears

- ▶ Tap "Close" in the message



- ▶ Open in the sequence

- **Add printer**

- **USB printer**

- > Connected USB printers are detected automatically

- ▶ Tap **Located printers**

- > The list of detected printers is displayed

- > If only one printer is connected, the printer is selected automatically

- ▶ Select the desired printer

- ▶ Tap **Located printers** once again

- > The available printer information, e.g. name and description, is displayed

- ▶ If required, enter a name for the printer into the **Name** input field



The text must not contain slashes ("/"), hash characters ("#") or spaces.

- ▶ Confirm the entry with **RET**

- ▶ If required, enter an optional description for the printer into the **Description** input field, e.g. "Color printer"

- ▶ Confirm the entry with **RET**

- ▶ If required, enter an optional location into the **Location** input field, e.g. "Office"

- ▶ Confirm the entry with **RET**

- ▶ If required, enter the connection parameters into the **Connection** input field, if they have not been entered automatically

- ▶ Confirm the entry with **RET**

- ▶ Tap **Select the driver**

- ▶ Select the appropriate driver for the printer type



If the appropriate driver is not listed, a suitable PPD file must be copied to the product.

Further information: "Finding PPD files", Page 134

- > The driver is activated

- ▶ Tap **Close** in the message
- ▶ Tap **Set standard values**
- ▶ Tap **Resolution** to set the printer resolution
- ▶ Select the desired resolution
- ▶ Tap **Resolution** once again
- ▶ Tap **Paper size** to set the paper size
- ▶ Select the desired paper size
- ▶ Depending on the type of printer, select further values such as type of paper or duplex print
- ▶ Tap **Properties**
- > The entered values are saved as defaults
- > The printer is added and can be used



Use the CUPS web interface to configure the enhanced settings of the connected printer. You can also use this web interface if the printer information fails over the product.

Further information: "Using CUPS", Page 135

Further information: "Printers", Page 232

Adding a network printer

Requirement: A network printer or network is connected to the product.

Further information: "Connecting a printer", Page 53

Further information: "Connecting a network peripheral", Page 54



- ▶ Tap **Settings** in the main menu



- ▶ Tap **General**
- ▶ Tap **Printers**
- ▶ Open in the sequence
 - **Add printer**
 - **Network printer**
- > Printers available on the network are detected automatically
- ▶ Tap **Located printers**
- > The list of detected printers is displayed
- > If only one printer is connected, the printer is selected automatically
- ▶ Select the desired printer
- ▶ Tap **Located printers** once again
- > The available printer information, e.g. name and description, is displayed
- ▶ If required, enter a name for the printer into the **Name** input field



The text must not contain slashes ("/"), hash characters("#") or spaces.

- ▶ Confirm the entry with **RET**
- ▶ If required, enter an optional description for the printer into the **Description** input field, e.g. "Color printer"
- ▶ Confirm the entry with **RET**
- ▶ If required, enter an optional location into the **Location** input field, e.g. "Office"
- ▶ Confirm the entry with **RET**
- ▶ If required, enter the connection parameters into the **Connection** input field, if they have not been entered automatically
- ▶ Confirm the entry with **RET**
- ▶ Tap **Select the driver**
- ▶ Select the appropriate driver for the printer type



If the appropriate driver is not listed, a suitable PPD file must be copied to the product.

Further information: "Finding PPD files", Page 134

- > The driver is activated
- ▶ Tap **Close** in the message
- ▶ Tap **Set standard values**

- ▶ Tap **Resolution** to set the printer resolution
- ▶ Select the desired resolution
- ▶ Tap **Resolution** once again
- ▶ Tap **Paper size** to set the paper size
- ▶ Select the desired paper size
- ▶ Depending on the type of printer, select further values such as type of paper or duplex print
- ▶ Tap **Properties**
 - > The entered values are saved as defaults
 - > The printer is added and can be used



Use the CUPS web interface to configure the enhanced settings of the connected printer. You can also use this web interface if the printer information fails over the product.

Further information: "Using CUPS", Page 135

Further information: "Printers", Page 232

Unsupported printers

To set up an unsupported printer, the product needs a "PPD" file containing information about the printer properties and drivers



This unit supports only drivers that are provided by Gutenprint (www.gutenprint.sourceforge.net).

Alternatively, you can select a similar printer from the list of supported printers. The scope of functionality may be limited but general printing should be possible.

Finding PPD files

Locate the required PPD file as follows:

- ▶ Search for the printer manufacturer and printer model at www.openprinting.org/printers
- ▶ Download the appropriate PPD file
- or
- ▶ Search for a Linux driver for the printer model on the website of the printer manufacturer
- ▶ Download the appropriate PPD file

Using PPD files

When configuring an unsupported printer, during the driver selection step you need to copy the located PPD file to the product:

- ▶ Tap **Select the driver**
- ▶ In the **Select the manufacturer** dialog tap **Select PPD file**
- ▶ Tap **Select file**
- ▶ To navigate to the desired PPD file, tap the **location** where the file is stored
- ▶ Navigate to the folder containing the downloaded PPD file
- ▶ Select the PPD file
- ▶ Tap **Select**
- > The PPD file is copied to the product
- ▶ Tap **Continue**
- > The PPD file is loaded and the driver is activated
- ▶ Tap **Close** in the message

Enhanced printer settings

Using CUPS

For printer control the product uses the Common Unix Printing System (CUPS). In the network, CUPS enables connected printers to be set up and managed using a web interface. These functions depend on whether the product uses a USB printer or network printer.

The CUPS web interface enables you to configure the enhanced settings of the printer connected to the product. You can also use this web interface if printer setup via the product fails.

Requirement: The product is connected to a network.

Further information: "Connecting a network peripheral", Page 54



- ▶ Tap **Settings** in the main menu



- ▶ Tap **Interfaces**
- ▶ Tap **Network**
- ▶ Tap the **X116** interface
- ▶ Specify and write down the IP address of the product from **IPv4 address**
- ▶ On a computer in the network, call the web interface of CUPS via the following URL:
http://[IP address of the product]:631
(e.g. http://10.6.225.86:631)
- ▶ In the web interface, click on the **Administration** tab and select the desired action

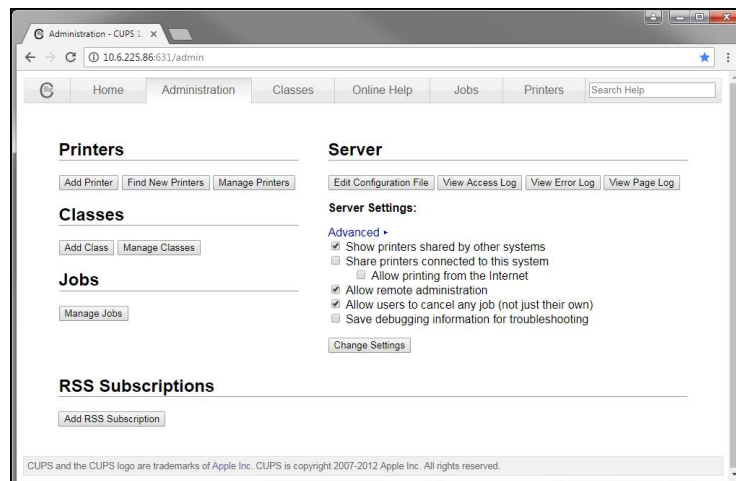

See the **Online Help** tab for detailed information about the CUPS web interface.

Modifying the resolution and paper size for a printer



- ▶ Tap **Settings** in the main menu



- ▶ Tap **General**
- ▶ Tap **Printers**
- ▶ If multiple default printers have been set up for the product, select the desired printer in the **Default printer** drop-down list
- ▶ Tap **Properties**
- ▶ Tap **Resolution** to set the printer resolution
 - > The resolutions provided by the driver are displayed
- ▶ Select the resolution
- ▶ Tap **Resolution** once again
- ▶ Tap **Paper size** to set the paper size
 - > The paper sizes provided by the driver are displayed
- ▶ Select the paper size
- > The entered values are saved as defaults



Depending on the type of printer, select further values such as type of paper or duplex print under **Properties**

Further information: "Printers", Page 232

Removing a printer



- ▶ Tap **Settings** in the main menu



- ▶ Tap **General**
- ▶ Open in the sequence:
 - **Printers**
 - **Remove printer**
- ▶ In the **Printers** drop-down list, select the printer you no longer need
 - > The model, location and connection of the printer are displayed
- ▶ Tap **Remove**
- ▶ Confirm with **OK**
- > The printer is removed from the list and can no longer be used

Configuring operation with a mouse or touchscreen

The product can be operated either via the touchscreen or a connected (USB) mouse. If the product is in its factory default setting, touching the touchscreen deactivates the mouse. Alternatively, you can set that the product is operated either only via the mouse or only via the touchscreen.

Requirement: A USB mouse is connected to the product.

Further information: "Connecting input devices", Page 53



- ▶ Tap **Settings** in the main menu



- ▶ Tap **Input devices**
- ▶ Select the desired option in the **Mouse substitute for multitouch gestures** drop-down list

Further information: "Input devices", Page 231

Configuring the USB keyboard

The factory default language for the keyboard assignment is English. You can switch the keyboard assignment to the desired language.

Requirement: A USB keyboard is connected to the product.

Further information: "Connecting input devices", Page 53



- ▶ Tap **Settings** in the main menu



- ▶ Tap **Input devices**
- ▶ Select the flag for the desired language in the **USB keyboard layout** drop-down list
- ▶ The keyboard assignment corresponds to the selected language

Further information: "Input devices", Page 231

8.3.2 Preparing machining processes (optional)

Depending on the intended use, the machine setter (**Setup**) can prepare the unit for a special machining process through configuration of the tool tables and preset tables.



The following activities can also be performed by **Operator**-type users.

Creating a tool table

You usually enter the coordinates according to the workpiece dimensions specified in the drawing.

In the **Milling** application mode, the unit can calculate the path of the tool center point with the help of the so-called tool radius compensation. To do this, you must enter the **Tool length** and **Tool diameter** for every tool.

In the **Turning** application mode, you must enter the tool coordinate **X** and the tool coordinate **Z** of the turning tool being used. You can perform tool setting directly at the lathe with the **Set tool data** function.

On the status bar you can access the tool table, which contains these specific parameters for each tool that is used. You can save a maximum of 99 tools in the tool table.

Tool No.	Tool Type	Diameter (D)	Length (L)	Unit
0	Drill	1.000	50.000	mm
1	Flat End Mill	6.000	50.000	mm
11	Bohrer 4.8	4.800	50.000	mm
12	Bohrer 6.1	6.100	50.000	mm
13	Bohrer 19.8	19.800	85.000	mm
14	Reibahle 20 H6	20.000	85.000	mm

Figure 27: Tool table with tool parameters in the **Milling** application mode

- 1 Tool type
- 2 Tool diameter
- 3 Tool length
- 4 Edit tool table

Tool parameters

You can define the following parameters:

	Description	Parameter	
Milling application mode	Tool type Designation that uniquely identifies the tool	DiameterD Diameter of the tool contact surface	LengthL Tool length along the tool axis
Turning application mode	Tool type Designation that uniquely identifies the tool	Tool coordinate X Intersection in the Z axis	Tool coordinate Z Intersection in the X axis

Creating a tool

Milling application mode



- ▶ Tap **Tools** on the status bar
- > The **Tools** dialog appears

Turning application mode



- ▶ Tap **Tools** on the status bar
- > The **Tools** dialog appears



- ▶ Tap **Open table**
- > The **Tool table** dialog appears



- ▶ Tap **Add**
- ▶ Enter a name in the **Tool type** input field
- ▶ Confirm the entry with **RET**
- ▶ Tap the input fields one after the other, and enter the corresponding values
- ▶ Change the unit of measure in the selection menu, if required
- > The entered values are converted
- ▶ Confirm the entry with **RET**
- > The defined tool is added to the tool table



- ▶ To protect the entry for a tool from accidental changes or deletion, tap the **Lock** symbol next to the tool's entry



- > The symbol changes and the entry is locked



- ▶ Tap **Close**
- > The **Tool table** dialog is closed

Setting the tool (in the Turning application mode)



- ▶ Tap **Manual operation** in the main menu
- > The user interface for Manual mode appears
- ▶ Tap **Additional functions** in the status bar



- ▶ Tap **Tool data** in the dialog
- > The **Set tool data** dialog box opens
- ▶ Move the tool to the desired position



- ▶ Tap **Save position**
- > The current position of the tool is saved
- ▶ Retract the tool to a safe position
- ▶ Enter the desired position data in the input fields



- ▶ Tap **Confirm** in the wizard
- > The **Select the tool** dialog appears
- ▶ Select the desired tool in the **Selected tool** input field:
 - ▶ To overwrite an existing tool, select an entry from the tool table
 - ▶ To add a new tool, enter a number that has not yet been assigned in the tool table and confirm by pressing **RET**



- ▶ Tap **Confirm** in the wizard
- > The probed coordinates are adopted for the tool

Deleting a tool

Milling application mode



- ▶ Tap **Tools** on the status bar
- > The **Tools** dialog appears

Turning application mode



- ▶ Tap **Tools** on the status bar
- > The **Tools** dialog appears



- ▶ Tap **Open table**
- > The **Tool table** dialog appears
- ▶ To select one or more tools, tap the checkbox in the relevant row
- > The active checkbox is highlighted in green



The entry for a tool can be locked to prevent accidental changes or deletion.

- ▶ Tap the **Unlock** symbol next to the entry
- > The symbol changes and the entry is unlocked



- ▶ Tap **Delete**
- > A message appears
- ▶ Close the message with **OK**
- > The selected tool is deleted from the tool table



- ▶ Tap **Close**
- > The **Tool table** dialog is closed

Creating a preset table

You can access the preset table on the status bar. The preset table contains the absolute positions of the presets with respect to the reference mark. You can save a maximum of 99 presets in the preset table.



Figure 28: Preset table with absolute positions in the **Milling** application mode

- 1 Designation
- 2 Coordinates
- 3 Edit preset table

Defining presets

You can define the preset table in the following ways:

Application	Name	Description
Milling	Probing	Probing of a workpiece with a HEIDENHAIN KT 130 edge finder. The unit automatically transfers the presets into the preset table
Milling Turning	Touch-off	Probing a workpiece using a tool. You must define the respective tool position manually as a preset
Milling Turning	Numerical input	You must manually enter the numeric value of the preset in the preset table







Depending on the application, users of the type **Operator** define the presets.

Functions for presetting by probing (in the Milling application mode)

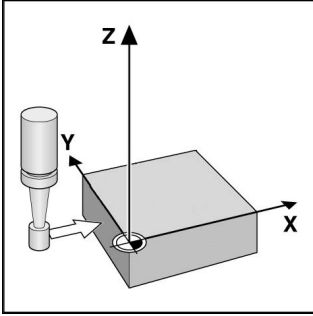
A wizard assists you in setting presets by probing.

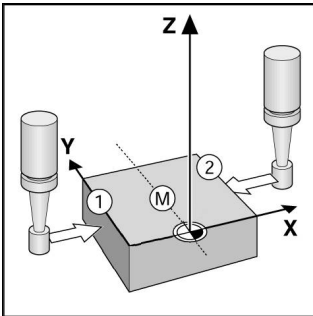
The following functions are available for probing a workpiece:

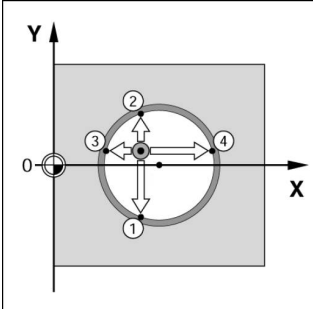
Icon	Function	Scheme
	Probe the edge of a workpiece (one probing procedure)	
	Determine the centerline of a workpiece (two probing procedures)	
	Determine the center point of a circular form (hole or cylinder) (three probing procedures with tool, four probing procedures with edge finder)	

Presetting by probing (in the Milling application mode)



- ▶ Tap **Manual operation** in the main menu
- > The user interface for manual operation is displayed
- ▶ Tap **Additional functions** in the status bar



- ▶ Tap the desired function in the dialog under **Probing**:



- ▶ Probe edge

or



- ▶ Find centerline

or



- ▶ Find the circle center

- ▶ Select the inserted tool in the **Select the tool** dialog:
 - ▶ When using a HEIDENHAIN KT 130 Edge Finder: Activate **Use touch probe**
 - ▶ When using a tool:
 - ▶ Deactivate **Use touch probe**
 - ▶ Enter the desired value in the **Tool diameter** input field
 - or
 - ▶ Select the corresponding tool from the tool table



- ▶ Tap **Confirm** in the wizard
- ▶ Follow the wizard's instructions for probing
- ▶ Keep in mind when probing:
 - ▶ Move the edge finder toward the workpiece edge until the red LED on the edge finder lights up
 - or
 - ▶ Move the tool until it touches the workpiece edge
 - ▶ Confirm each step in the wizard
 - ▶ Retract the edge finder or tool after the last probing operation

- > The **Select preset** dialog appears after the last probing procedure
- ▶ Select the desired preset in the **Selected preset** input field:
 - ▶ To overwrite an existing preset, select an entry from the preset table
 - ▶ To add a new preset, enter a number that has not yet been assigned in the preset table
 - ▶ Confirm the entry with **RET**
- ▶ Enter the desired value in the **Set position values** input field:
 - ▶ Leave the input field empty to load the measured value
 - ▶ To define a new value, enter the desired value
 - ▶ Confirm the entry with **RET**



- ▶ Tap **Confirm** in the wizard
- > The probed coordinate is loaded as preset

Presetting by probing (in the Turning application mode)



- ▶ Tap **Manual operation** in the main menu
- > The user interface for Manual mode is displayed
- ▶ Tap **Additional functions** in the status bar



- ▶ Tap **Presets** in the dialog
- > The **Set preset data** dialog box opens
- ▶ Move the tool to the desired position



- ▶ Tap **Save position**
- > The current position of the tool is saved
- ▶ Retract the tool to a safe position
- ▶ Enter the desired position data in the input fields



- ▶ Tap **Confirm** in the wizard
- > The dialog Select preset opens
- ▶ Select the desired preset in the **Selected preset** input field:
 - ▶ To overwrite an existing preset, select an entry from the preset table
 - ▶ To create a new preset, enter a number that has not yet been assigned in the preset table and confirm with **RET**



- ▶ Tap **Confirm** in the wizard
- > The probed coordinates are adopted as a preset

Manual datum setting

If you create presets manually in the preset table, the following applies:

- The entry in the preset table assigns the new position values to the current actual position of the individual axes
- Clearing the entry with **CE** resets the position values for the individual axes to the machine datum again. The new position values are thus always referenced to the machine datum



- ▶ Tap **Presets** on the status bar
- > The **Presets** dialog appears



- ▶ Tap **Open table**
- > The **Preset table** dialog appears



- ▶ Tap **Add**
- ▶ Enter a name in the **Description** input field
- ▶ Tap the input field for one or more desired axes and enter the appropriate position value
- ▶ Confirm the entry with **RET**
- > The defined preset is added to the preset table



- ▶ To protect the entry for a preset from accidental changes or deletion, tap the **Lock** symbol next to the preset's entry
- > The symbol changes and the entry is locked



- ▶ Tap **Close**
- > The **Preset table** dialog is closed

Deleting presets



- ▶ Tap **Datums** on the status bar
- > The **Presets** dialog appears



- ▶ Tap **Open table**
- > The **Preset table** dialog appears
- ▶ To select one or more presets, tap the checkbox in the relevant row
- > The active checkbox is highlighted in green



The entry for a preset can be locked to prevent accidental changes or deletion.

- ▶ Tap the **Unlock** symbol next to the entry
- > The symbol changes and the entry is unlocked



- ▶ Tap **Delete**
- > A message appears
- ▶ Close the message with **OK**
- > The selected preset(s) is/are deleted from the preset table



- ▶ Tap **Close**
- > The **Preset table** dialog is closed

8.4 Back up settings

The settings of the product can be backed up as a file to make it available after a reset to the factory default settings or for installation on multiple products.



- ▶ Tap **Settings** in the main menu



- ▶ Tap **Service**
- ▶ Open in the sequence
 - **Back up and restore**
 - **Back up settings**

Complete backup

During a complete backup of the configuration, all settings of the product are backed up.

- ▶ Tap **Complete backup**
- ▶ If required, connect a USB mass storage device (FAT32 format) to a USB port of the product
- ▶ Select the folder to which you want to copy the configuration data
- ▶ Specify a name for the configuration data, e.g. "<yyy-mm-dd>_config"
- ▶ Confirm the entry with **RET**
- ▶ Tap **Save as**
- ▶ Tap **OK** to confirm the successful backup of the configuration
- > The configuration file was backed up

Further information: "Back up and restore", Page 260

Safely removing a USB mass storage device



- ▶ Tap **File management** in the main menu
- ▶ Navigate to the list of storage locations
- ▶ Tap **Safely remove**



- > The message **The storage medium can be removed now.** appears
- ▶ Disconnect the USB mass storage device

8.5 Back up user files

The user files of the product can be backed up as a file to make it available after a reset to the factory default state or for installation on multiple products.

Performing back up

The user files can be backed up as a ZIP file on a USB mass storage device or connected network drive.



- ▶ Tap **Settings** in the main menu



- ▶ Tap **Service**
- ▶ Open in the sequence
 - **Back up and restore**
 - **Back up user files**
- ▶ Tap **Save as ZIP**
- ▶ If required, connect a USB mass storage device (FAT32 format) to a USB port of the product
- ▶ Select the folder to which you want to copy the ZIP file
- ▶ Specify a name for the ZIP file, e.g. "<yyyy-mm-dd>_config"
- ▶ Confirm the entry with **RET**
- ▶ Tap **Save as**
- ▶ Tap **OK** to confirm successful backup of the user files
- > The user files were backed-up.

Further information: "Back up and restore", Page 260

Safely removing a USB mass storage device



- ▶ Tap **File management** in the main menu
- ▶ Navigate to the list of storage locations
- ▶ Tap **Safely remove**



- > The message **The storage medium can be removed now.** appears
- ▶ Disconnect the USB mass storage device

9

**Milling – Quick
Start**

9.1 Overview

This chapter describes the production of an example workpiece. While you produce the example workpiece, this chapter leads step by step through the product's various operating modes with use of various machining options. You need to carry out the following machining steps for successful production of the flange:

Machining step	Mode of operation
Determine preset 0	Manual operation
Process a through hole	Manual operation
Process a rectangular pocket	MDI mode
Process a fit	MDI mode
Determine preset 1	Manual operation
Process a bolt hole circle	MDI mode
Process a row of holes	MDI mode

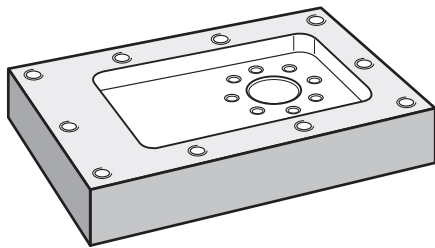

Figure 29: Example workpiece

This chapter does not describe processing of the outside contour of the example workpiece. It is presumed that the outside contour is already machined.



Make sure that you have read and understood the "Basic Operation" chapter before carrying out the actions described below.

Further information: "Basic Operation", Page 57

9.2 Logging in for Quick Start

User login

For Quick Start, the **Operator** user must log in.



- ▶ Tap **User login** in the main menu
- ▶ If required, log out the user who is currently logged in
- ▶ Select the **Operator** user
- ▶ Tap the **Password** input field
- ▶ Enter the password "operator"



If the password does not match the default password, ask a **Setup** user or **OEM** user for the assigned password.

If the password is no longer known, contact a HEIDENHAIN service agency.



- ▶ Confirm entry with **RET**
- ▶ Tap **Log in**

9.3 Requirements

To manufacture the aluminum flange, use a manually operated machined tool. The following dimensioned technical drawing is available for the flange:

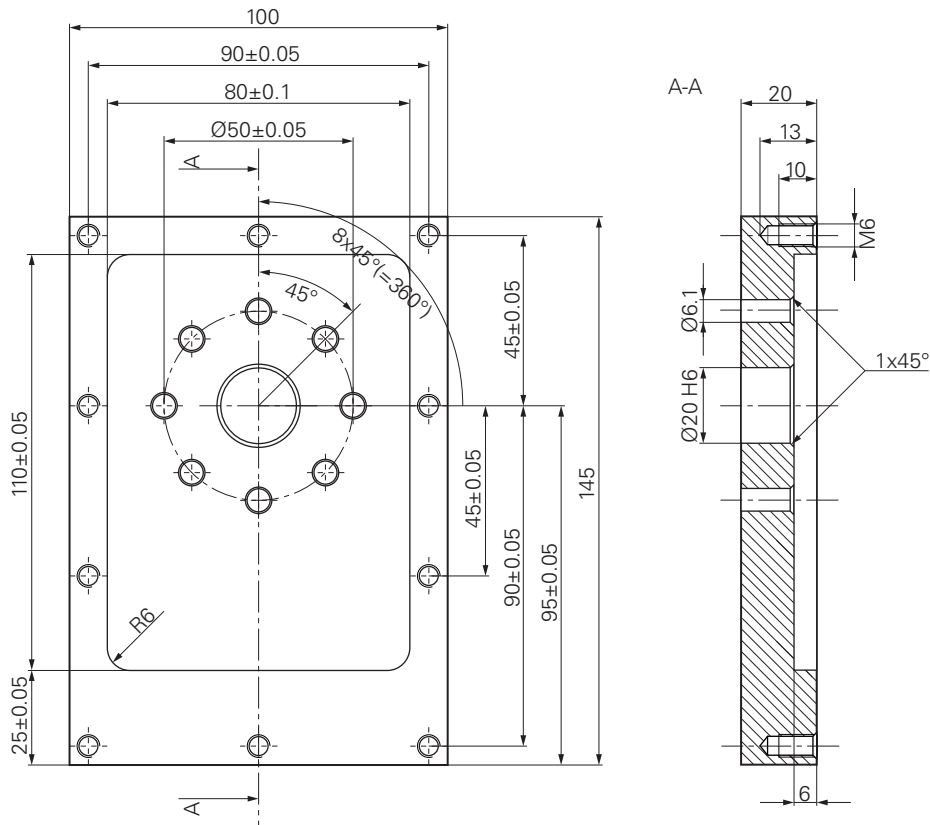

Figure 30: Example workpiece– technical drawing

Machine tool

- The machine tool is switched on
- A pre-processed workpiece blank is clamped on the machine tool

Product

- A unit with the ID number 1089179-xx and configured spindle axis
- The reference mark search has been performed
- **Further information:** "Conducting the reference mark search", Page 183
- A HEIDENHAINKT 130 Edge Finder is available

Tools

The following tools are available:

- Drill Ø 5.0 mm
- Drill Ø 6.1 mm
- Drill Ø 19.8 mm
- Reamer Ø 20 mm H6
- End mill Ø 12 mm
- Countersink Ø 25 mm 90°
- Tap M6

Tool table

For the example it is presumed that the tools for machining are not yet defined.

For each tool used, you must therefore define the specific parameters in the tool table of the product. During subsequent machining you can access the parameters in the tool table via the status bar.

Further information: "Creating a tool table", Page 138



▶ Tap **Tools** on the status bar

> The **Tools** dialog appears



▶ Tap **Open table**

> The **Tool table** dialog appears



▶ Tap **Add**

▶ In the **Tool type** input field enter the name **Drill 5.0**

▶ Confirm the entry with **RET**

▶ In the **Diameter** input field, enter the value **5.0**

▶ Confirm the entry with **RET**

▶ In the **Length** input field enter the length of the drill

▶ Confirm the entry with **RET**

> The defined Ø 5.0 mm drill is added to the tool table

▶ Repeat the sequence for the other tools using the naming convention **[type] [diameter]**



▶ Tap **Close**

> The **Tool table** dialog is closed

9.4 Determining the preset (manual operation mode)

Initially you need to determine the first preset. Based on this preset the product then calculates all values for the relative coordinate system. Ascertain the preset with the HEIDENHAIN KT 130 Edge Finder.

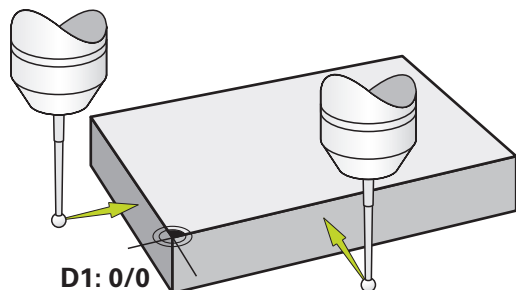

Figure 31: Example workpiece – finding preset D1

Activation



- ▶ Tap **Manual operation** in the main menu
- The user interface for manual operation is displayed

Probe the preset D1



- ▶ On the machine tool, insert the HEIDENHAIN KT 130 Edge Finder into spindle and connect to the product
Further information: "Configuring a touch probe (in the Milling application mode)", Page 105
- ▶ Tap **Additional functions** in the status bar



- ▶ In the dialog, tap **Probe edge**
- The **Select the tool** dialog box opens
- ▶ In the **Select the tool** dialog, activate the **Use touch probe** option
- ▶ Follow the wizard's instructions and define the preset by probing in the X direction
- ▶ Move the edge finder toward the workpiece edge until the red LED on the edge finder lights up
- The **Select preset** dialog box opens
- ▶ Retract the edge finder from the workpiece edge
- ▶ In the **Selected preset** field, select the preset **0** from the preset table
- ▶ In the **Set position values** field enter the value **0** for the X direction and confirm with **RET**



- ▶ Tap **Confirm** in the wizard
- The probed coordinate is loaded in preset **0**
- ▶ Repeat the procedure and define the preset in the Y direction via probing

9.5 Machining a through hole (manual operation mode)

In the first machining step you drill the through hole in manual operation mode using the \varnothing 5.0 mm drill. You then drill the through hole with the \varnothing 19.8 mm drill. The values to be entered into the input fields can be taken directly from the dimensioned production drawing.

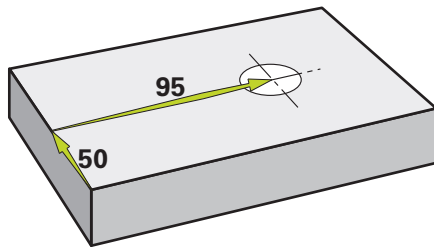

Figure 32: Example workpiece – drilling a through hole

Activation



- ▶ Tap **Manual operation** in the main menu
- > The user interface for manual operation is displayed

9.5.1 Predrilling the through hole



- ▶ On the machine tool, insert the \varnothing 5.0 mm drill into the spindle
- ▶ Tap **Tools** on the status bar
- > The **Tools** dialog appears
- ▶ Tap **Drill 5.0**



- ▶ Tap **Confirm**
- > The associated tool parameters are applied automatically
- > The **Tools** dialog is closed



- ▶ On the product, set a spindle speed of 3500 rpm
- ▶ On the machine tool move the spindles as follows:
 - X direction: 95 mm
 - Y direction: 50 mm



- ▶ On the **OEM bar**: Tap **Coolant ON**
- ▶ Predrill the through hole and retract the spindle
- ▶ Keep positions X and Y
- ▶ On the **OEM bar**: Tap **Coolant OFF**
- > You have successfully predrilled the through hole

9.5.2 Drilling out the through hole



▶ On the machine tool, insert the Ø 19.8 mm drill into the spindle

▶ Tap **Tools** on the status bar

> The **Tools** dialog appears

▶ Tap **Drill 19.8**

▶ Tap **Confirm**

> The associated tool parameters are applied automatically

> The **Tools** dialog is closed

▶ On the product, set a spindle speed of 400 rpm



▶ On the **OEM bar**: Tap **Coolant ON**

▶ Drill out the through hole and retract the spindle

▶ On the **OEM bar**: Tap **Coolant OFF**

> You have successfully drilled out the through hole

9.6 Machining a rectangular pocket (MDI mode of operation)

Machine the rectangular pocket in MDI mode of operation. The values to be entered into the input fields can be taken directly from the dimensioned production drawing.

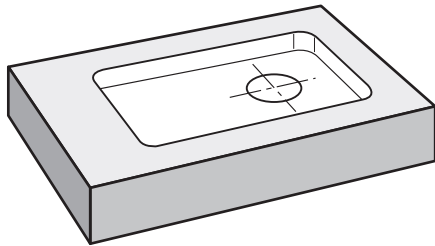

Figure 33: Example workpiece – machining a rectangular pocket

Activation



- ▶ Tap **MDI** in the main menu
- > The user interface for the MDI mode is displayed

9.6.1 Defining the rectangular pocket



▶ Tap **Tools** on the status bar

> The **Tools** dialog appears

▶ Tap **End mill**



▶ Tap **Confirm**

> The associated tool parameters are applied automatically

> The **Tools** dialog is closed



▶ Move the tool until it touches the surface of the flange

▶ Hold down **Z** in the position display

> The product displays 0 with the Z axis



▶ Tap **Create** on the status bar

> A new block is displayed

▶ In the **Block type** drop-down list select the **Rectangular pocket** block type

▶ Enter the following parameters according to the dimensional data:

■ **Clearance height:** 10

■ **Depth:** -6

■ **X coordinate of center:** 80

■ **Y coordinate of center:** 50

■ **Side length in X:** 110

■ **Side length in Y:** 80

■ **Direction:** clockwise

■ **Finishing allowance:** 0.2

▶ Confirm each entry with **RET**



▶ To run the block, tap **END**

> The positioning aid is displayed

> If the simulation window is active, the rectangular pocket is visualized

9.6.2 Milling the rectangular pocket



The values for spindle speed, milling depth and feed rate depend on the end mill's metal-removal rate and the machine tool.



- ▶ On the machine tool, insert the \varnothing 12 mm end mill into the spindle
- ▶ On the product, set the spindle speed to a suitable value
- ▶ On the **OEM bar**: Tap **Coolant ON**
- ▶ Follow the instructions of the wizard
- ▶ Set the milling cutter to the desired milling depth
- ▶ Start the machining – follow the instructions of the wizard
- > The product executes the individual steps of the milling procedure
- ▶ On the **OEM bar**: Tap **Coolant OFF**
- ▶ Retract the spindle
- ▶ Tap **Close**
- > Program run is terminated
- > The wizard closes
- > You have successfully machined the rectangular pocket



9.7 Machining a fit (MDI mode of operation)

Machine the fit in MDI mode of operation. The values to be entered into the input fields can be taken directly from the dimensioned production drawing.



You should chamfer the through hole before reaming. The chamfer enables a better first cut of the reamer and prevents burr formation.

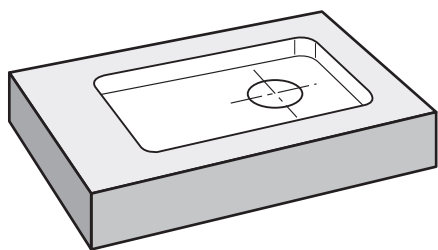

Figure 34: Example workpiece – machining a fit

Activation



- ▶ Tap **MDI** in the main menu
- > The user interface for the MDI mode is displayed

9.7.1 Defining the fit



- ▶ Tap **Tools** on the status bar
- > The **Tools** dialog appears
- ▶ Tap **Reamer**



- ▶ Tap **Confirm**
- > The associated tool parameters are applied automatically
- > The **Tools** dialog is closed



- ▶ Tap **Create** on the status bar
- > A new block is displayed
- ▶ In the **Block type** drop-down list select the **Positioning** block type
- ▶ Enter the following parameters according to the dimensional data:
 - **X coordinate:** 95
 - **Y coordinate:** 50
 - **Z coordinate:** drill through



- ▶ To run the block, tap **END**
- > The positioning aid is displayed
- > If the simulation window is active, the position and traverse path are visualized

9.7.2 Reaming the fit

- ▶ On the machine tool, insert the \varnothing 20 mm H6 reamer into the spindle
- ▶ On the product, set a spindle speed of 250 rpm



- ▶ On the **OEM bar**: Tap **Coolant ON**
- ▶ Follow the instructions of the wizard
- ▶ Ream the through hole and retract the spindle
- ▶ On the **OEM bar**: Tap **Coolant OFF**
- ▶ Tap **Close**
- > Program run is terminated
- > The wizard closes
- > You have successfully machined the fit

9.8 Determining the preset (manual operation mode)

To align the bolt hole circle and frame of holes you must set the circle center of the fit as the preset. Based on this preset the product then calculates all values for the relative coordinate system. Ascertain the preset with the HEIDENHAIN KT 130 Edge Finder.

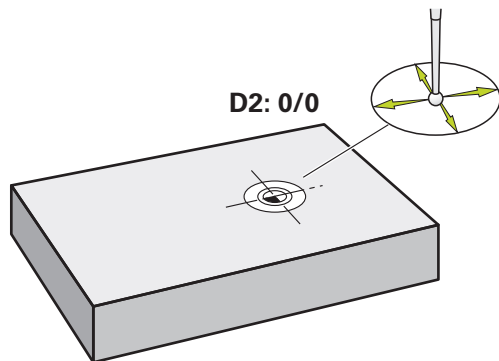

Figure 35: Example workpiece – finding preset D2

Activation



- ▶ Tap **Manual operation** in the main menu
- The user interface for manual operation is displayed

Probing preset D2



- ▶ On the machine tool, insert the HEIDENHAIN KT 130 Edge Finder into spindle and connect to the product
Further information: "Configuring a touch probe (in the Milling application mode)", Page 105
- ▶ Tap **Additional functions** in the status bar



- ▶ Tap **Find circle center** in the dialog
- The **Select the tool** dialog box opens
- ▶ In the **Select the tool** dialog, activate the **Use touch probe** option
- ▶ Follow the instructions of the wizard
- ▶ Move the edge finder toward the workpiece edge until the red LED on the edge finder lights up
- The **Select preset** dialog box opens
- ▶ Retract the edge finder from the workpiece edge
- ▶ In the **Selected preset** field, select preset **1**
- ▶ In the **Set position values** field, enter the value **0** for position value X and position value Y and confirm with **RET**



- ▶ Tap **Confirm** in the wizard
- The probed coordinates are loaded in preset **1**

Activating the preset

- ▶ Tap **Presets** on the status bar
- > The **Presets** dialog box opens
- ▶ Tap preset **1**



- ▶ Tap **Confirm**
- > The preset is set
- > On the status bar **1** is displayed with preset

9.9 Drilling a circular hole pattern (MDI mode)

Drill the circular hole pattern in MDI mode. The values to be entered into the input fields can be taken directly from the dimensioned production drawing.

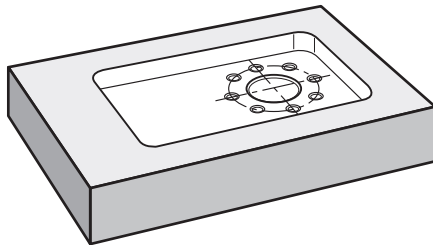

Figure 36: Example workpiece – drilling a circular hole pattern

Activation

- ▶ Tap **MDI** in the main menu
- > The user interface for the MDI mode is displayed

9.9.1 Defining the circular hole pattern



- ▶ Tap **Tools** on the status bar

> The **Tools** dialog appears

- ▶ Tap **Drill 6.1**



- ▶ Tap **Confirm**

> The associated tool parameters are applied automatically

> The **Tools** dialog is closed



- ▶ Tap **Create** on the status bar

> A new block is displayed

- ▶ In the **Block type** drop-down list, select the **Bolt hole circle** block type

> Enter the following parameters according to the dimensional data:

- **Number of holes:** 8
- **X coordinate of center:** 0
- **Y coordinate of center:** 0
- **Radius:** 25

- ▶ Confirm each entry with **RET**

> Leave all the other values as defaults

- ▶ To run the block, tap **END**



> The positioning aid is displayed

> If the simulation window is active, the rectangular pocket is visualized

9.9.2 Drilling the circular hole pattern

- ▶ On the machine tool, insert the Ø 6.1 mm drill into the spindle



- ▶ On the product, set a spindle speed of 3500 rpm



- ▶ On the **OEM bar**: Tap **Coolant ON**

> Follow the instructions of the wizard

> Drill the circular hole pattern and retract the spindle

- ▶ On the **OEM bar**: Tap **Coolant OFF**



- ▶ Tap **Close**

> Program run is terminated

> The wizard closes

> You have successfully completed the circular hole pattern

9.10 Drilling a circular hole pattern (MDI operation)

Drill the circular hole pattern in MDI mode. The values to be entered into the input fields can be taken directly from the dimensioned production drawing.

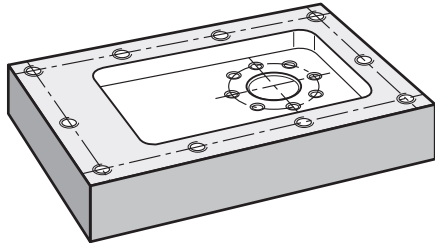

Figure 37: Example workpiece – drilling a circular hole pattern

Activation



- ▶ Tap **MDI** in the main menu
- > The user interface for the MDI mode is displayed

9.10.1 Defining the circular hole pattern



- ▶ Tap **Tools** on the status bar
- > The **Tools** dialog appears



- ▶ Tap **Drill 5.0**
- ▶ Tap **Confirm**
- > The associated tool parameters are applied automatically
- > The **Tools** dialog is closed



- ▶ Tap **Create** on the status bar
- > A new block is displayed
- ▶ In the **Block type** drop-down list, select the **Row of holes** block type
- ▶ Enter the following parameters according to the dimensional data:

- **X coordinate of 1st hole:** -90
- **Y coordinate of 1st hole:** -45
- **Holes per row:** 4
- **Hole spacing:** 45
- **Angle:** 0°
- **Depth:** -13
- **Number of rows:** 3
- **Row spacing:** 45
- **Fill mode:** frame of holes

- ▶ Confirm each entry with **RET**



- ▶ To run the block, tap **END**
- > The positioning aid is displayed
- > If the simulation window is active, the rectangular pocket is visualized

9.10.2 Drilling the row of holes

- ▶ On the machine tool, insert the \varnothing 5.0 mm drill into the spindle
- ▶ On the product, set a spindle speed of 3500 rpm

- 3500 +



- ▶ On the **OEM bar**: Tap **Coolant ON**
- ▶ Follow the instructions of the wizard
- ▶ Drill the row of holes and retract the spindle
- ▶ On the **OEM bar**: Tap **Coolant OFF**



- ▶ Tap **Close**
- > Program run is terminated
- > The wizard closes
- > You have successfully completed the row of holes

10

**Turning – Quick
Start**

10.1 Overview

This chapter describes the production of an example workpiece. This chapter will guide you step by step through the unit's various machining options as you machine the example workpiece. For successful machining of the bearing seat, you will need to perform the following machining steps:

Machining step	Mode of operation
Setting up the lathe	Manual operation
Roughing the outside contour	Manual operation
Turning the recesses	Manual operation
Finishing the outside contour	Manual operation

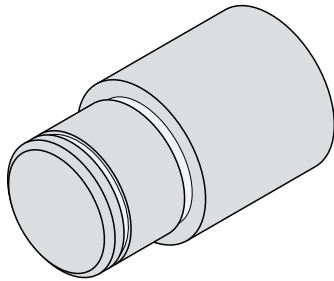

Figure 38: Example workpiece



Make sure that you have read and understood the "Basic Operation" chapter before carrying out the actions described below.

Further information: "Basic Operation", Page 57

10.2 Logging in for Quick Start

User login

For Quick Start, the **Operator** user must log in.



- ▶ Tap **User login** in the main menu
- ▶ If required, log out the user who is currently logged in
- ▶ Select the **Operator** user
- ▶ Tap the **Password** input field
- ▶ Enter the password "operator"



If the password does not match the default password, ask a **Setup** user or **OEM** user for the assigned password.

If the password is no longer known, contact a HEIDENHAIN service agency.

- ▶ Confirm entry with **RET**
- ▶ Tap **Log in**



10.3 Requirements

Use a manually operated lathe to machine the bearing seat. The following dimensioned technical drawing is available for the bearing seat:

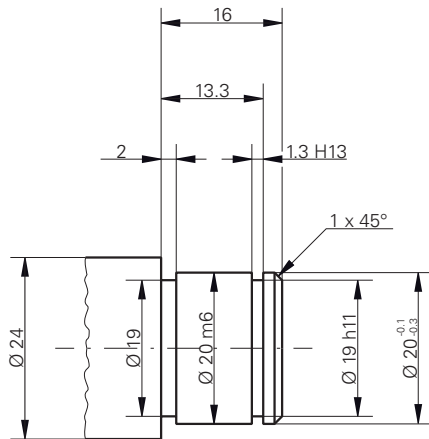

Figure 39: Example workpiece – technical drawing

Lathe

- The lathe is switched on
- A workpiece blank with Ø 24 mm is clamped into the lathe

Product

- The reference mark search has been performed
Further information: "Conducting the reference mark search", Page 183

Tools

The following tools are available:

- Roughing tool
- Finishing tool
- Recessing tool (1 mm)
- Turning chisel (45°)

Tool table

For the example it is presumed that the tools for machining are not yet defined. You must add in advance all of the tools to be used to the tool table.

Further information: "Creating a tool table", Page 138



- ▶ Tap **Tools** on the status bar
- > The **Tools** dialog appears



- ▶ Tap **Open table**
- > The **Tool table** dialog appears



- ▶ Tap **Add**
- ▶ Enter the designation **Finishing tool** in the **Tool type** input field
- ▶ Confirm the entry with **RET**
- ▶ Enter the value **0** in the **X** input field
- ▶ Confirm the entry with **RET**
- ▶ Enter the value **0** in the **Z** input field
- ▶ Confirm the entry with **RET**
- > The defined finishing tool is added to the tool table
- ▶ Repeat this process for the other tools



- ▶ Tap **Close**
- > The **Tool table** dialog is closed

10.4 Setting up the lathe

In the initial machining step, you first need to set up the lathe. The unit requires the parameters of the individual tools for the calculation for the relative coordinate system. In order to manufacture a workpiece, you will need one of the presets you defined.

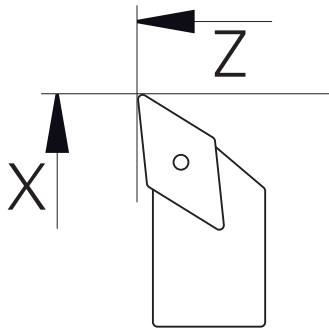

Figure 40: Finishing tool parameters

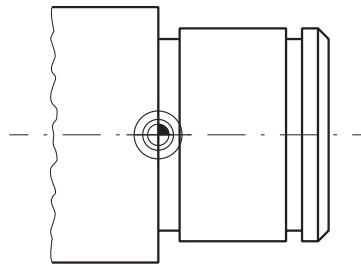

Figure 41: Datum

Activation



- ▶ Tap **Manual operation** in the main menu
- > The user interface for manual operation is displayed

Coupling axes



For a lathe with a **Z** saddle and a **Zo** top slide, you have the option of coupling both the **Z** and **Zo** axes.



- ▶ In the working space, drag the **Z axis key** to the right



- ▶ Tap **Couple**
- > The **Zo** axis is now coupled with the **Z** axis



- > The icon for the coupled axes is shown next to the **Z axis key**
- > The position value for the coupled axes is shown as a sum

10.4.1 Measuring the reference tool

For every tool used, you must determine the position of the cutting edges (for X and/or Z) in relation to the machine coordinate system or to the workpiece preset. To do so, you must first define a tool based on which all further parameters of the other tools are calculated. In this example, the finishing tool will be used as the reference tool.



- ▶ On the lathe, place the finishing tool into the tool holder
- ▶ Tap **Tools** on the status bar
- > The **Tools** dialog appears
- ▶ Tap **Finishing tool**



- ▶ Tap **Confirm**
- > The finishing tool appears in the status bar
- ▶ On the lathe, set the spindle speed to 1500 rpm
- ▶ Tap **Additional functions** in the status bar



- ▶ Tap **Tool data**
- > The **Set tool data** dialog box opens
- ▶ Approach the workpiece blank with the finishing tool and perform a touch-off



- ▶ When the appropriate Z value is reached, tap **Save position**
- ▶ Perform face turning with the finishing tool
- ▶ Retract the tool to a safe position
- ▶ In the **Z** input field, enter the value **0**



- ▶ Approach the workpiece blank with the finishing tool
- ▶ When the appropriate X value is reached, tap **Save position**
- ▶ Turn a step on the outside diameter of the workpiece blank using the finishing tool
- ▶ Retract the tool to a safe position
- ▶ Spindle OFF

- ▶ Measure the turned outside diameter using an appropriate means of measurement
- ▶ Enter the measured value in the **X** input field



- ▶ Tap **Confirm** in the wizard
- > The **Select the tool** dialog appears
- ▶ Tap **Finishing tool**



- ▶ Tap **Confirm** in the wizard
- > The parameters are adopted in the tool table

10.4.2 Tool measurement

You have already defined a finishing tool as the reference tool. For every additional tool, you must determine its offset from the reference tool. During measurement, the parameters of the measured tool are automatically offset from the parameters of the reference tool. The measured parameters are separate for each tool and are retained even after you have deleted the reference tool. In the example, the roughing tool is added as a tool.



- ▶ On the lathe, insert the roughing tool into the tool holder
- ▶ Tap **Tools** on the status bar
- > The **Tools** dialog appears
- ▶ Tap **Roughing tool**



- ▶ Tap **Confirm**
- > The **Roughing tool** is shown in the status bar
- ▶ On the lathe, set the spindle speed to 1500 rpm
- ▶ Tap **Additional functions** in the status bar



- ▶ Tap **Tool data**
- > The **Set tool data** dialog box opens
- ▶ Slowly approach the plane surface until tiny chips occur
- ▶ When the appropriate Z value is reached, tap **Save position**
- ▶ Retract the tool to a safe position
- ▶ In the **Z** input field, enter the value **0**



- ▶ Approach the workpiece blank with the roughing tool
- ▶ When the appropriate X value is reached, tap **Save position**
- ▶ Turn a step on the outside diameter of the workpiece blank using the roughing tool
- ▶ Retract the tool to a safe position
- ▶ Spindle OFF



- ▶ Measure the turned outside diameter using an appropriate means of measurement
- ▶ Enter the measured value in the **X** input field



- ▶ Tap **Confirm** in the wizard
- > The **Select the tool** dialog appears
- ▶ Tap **roughing tool**



- ▶ Tap **Confirm** in the wizard
- > The parameters are added to the tool table
- ▶ Repeat this process for the other tools

10.4.3 Finding the preset

To machine the bearing seat, you will need to find the preset. According to the drawing, the dimensions are referenced to the mating surface of the bearing. In the drawing, the mating surface of the bearing is highlighted in green. Based on this preset the product then calculates all values for the relative coordinate system.

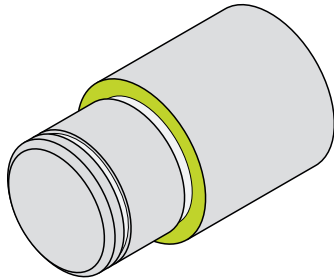

Figure 42: Example workpiece – finding the preset



- ▶ On the lathe, insert the finishing tool into the tool holder
- ▶ Tap **Tools** on the status bar
- > The **Tools** dialog appears
- ▶ Tap **Finishing tool**



- ▶ Tap **Confirm**
- > The **Finishing tool** is shown in the status bar



- ▶ Tap **Additional functions** in the status bar



- ▶ Tap **Presets** in the dialog
- > The **Set preset data** dialog box opens
- ▶ On the workpiece blank, move the finish-turning tool along **Z** in the negative direction for approx. 17 mm



- ▶ Tap **Save position**
- > The current position of the tool is saved
- ▶ Retract the tool to a safe position
- ▶ In the **Z** input field, enter the value **0**



- ▶ Tap **Confirm** in the wizard
- > The **Select preset** dialog appears
- ▶ Select preset **0** in the **Selected preset** input field



- ▶ Tap **Confirm** in the wizard
- > The probed coordinate is loaded as preset

10.5 Roughing the outside contour

In the second machining step, you will rough the outside contour. The entire contour must be turned with a finishing allowance. A finishing allowance ensures that you will be able to produce a flawless surface using the finishing tool in the final machining step.

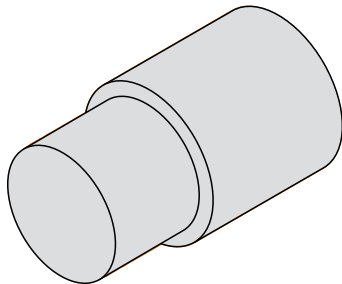

Figure 43: Example workpiece – roughing the outside contour



- ▶ On the lathe, insert the roughing tool into the tool holder
- ▶ Tap **Tools** on the status bar
- ▶ The **Tools** dialog appears
- ▶ Tap **Roughing tool**
- ▶ Tap **Confirm**
- ▶ The associated tool parameters are applied automatically
- ▶ The **Tools** dialog is closed
- ▶ On the lathe, set the spindle speed to 1500 rpm
- ▶ Move the tool into position on the lathe:
 - X: 25.0 mm
 - Z: 16.2 mm
- ▶ Perform the face-turning operation with the roughing tool
- ▶ Retract the tool to a safe position
- ▶ Move the tool into position on the lathe:
 - X: 20.2 mm
 - Z: 17.0 mm
- ▶ Move the tool into position on the lathe:
 - Z: 0.2 mm
- ▶ Move the tool into position on the lathe:
 - X: 25.0 mm
- ▶ Retract the tool to a safe position
- ▶ Spindle OFF
- ▶ You have now successfully roughed the outside contour

10.6 Turning the recesses

In the third machining step, you will turn both recesses. One of the recesses serves as an undercut for the mating surface, and the second recesses will hold the securing ring.

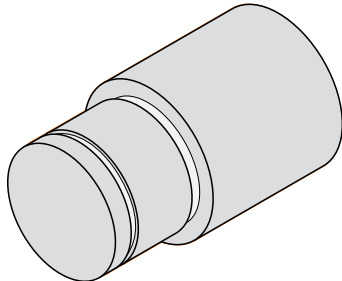

Figure 44: Example workpiece – turning the recesses



- ▶ On the lathe, insert the recessing tool into the tool holder
- ▶ Tap **Tools** on the status bar
- > The **Tools** dialog appears
- ▶ Tap **Recessing tool 1 mm**
- ▶ Tap **Confirm**
- > The associated tool parameters are applied automatically
- > The **Tools** dialog is closed
- ▶ On the lathe, set the spindle speed to 400 rpm
- ▶ Move the tool into position on the lathe:
 - X: 21.0 mm
 - Z: 12.3 mm
- ▶ Move the tool into position on the lathe:
 - X: 18.935 mm
- ▶ Move the tool into position on the lathe:
 - X: 21.0 mm
- ▶ Move the tool into position on the lathe:
 - Z: 12.0 mm
- ▶ Move the tool into position on the lathe:
 - X: 18.935 mm
- ▶ Move the tool into position on the lathe:
 - X: 21.0 mm
- ▶ Retract the tool to a safe position
- ▶ Repeat the procedure for the second recess
- ▶ Switch off the spindle
- > You have successfully machined the recesses

10.7 Finishing the outside contour

In the fourth and final machining step, you will machine the outside contour using the finishing tool.

i Prior to finishing, you should first machine the chamfer (1 x 45°) and lightly chamfer all of the other edges so as to prevent the formation of burrs.

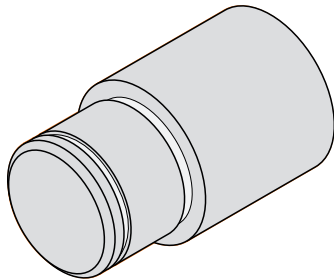

Figure 45: Example workpiece – finishing the outside contour



- ▶ On the lathe, insert the finishing tool into the tool holder
- ▶ Tap **Tools** on the status bar
- ▶ The **Tools** dialog appears
- ▶ Tap **Finishing tool**
- ▶ Tap **Confirm**
- ▶ The associated tool parameters are applied automatically
- ▶ The **Tools** dialog is closed
- ▶ On the lathe, set the spindle speed to 1500 rpm
- ▶ Move the tool into position on the lathe:
 - X: 25.0 mm
 - Z: 16.0 mm
- ▶ Perform face turning with the finishing tool
- ▶ Retract the tool to a safe position
- ▶ Move the tool into position on the lathe:
 - X: 19.8 mm
 - Z: 17.0 mm
- ▶ Move the tool into position on the lathe:
 - Z: 12.5 mm
- ▶ Move the tool into position on the lathe:
 - X: 20.015 mm
- ▶ Move the tool into position on the lathe:
 - Z: 1.5 mm
- ▶ Move the tool into position on the lathe:
 - X: 19.5 mm
- ▶ Move the tool into position on the lathe:
 - Z: 0.0 mm
- ▶ Move the tool into position on the lathe:
 - X: 25.0 mm

- ▶ Retract the tool to a safe position
- ▶ Spindle OFF
- > You have now successfully finish turned the outside contour

11

**Milling – Manual
operation**

11.1 Overview

This chapter describes the "Manual operation" mode and how to execute simple machining steps in this mode on a workpiece.

i Make sure that you have read and understood the "Basic Operation" chapter before carrying out the actions described below.

Further information: "Basic Operation", Page 57

Short description

By traversing the reference marks on the encoder scales, you make it possible to define an absolute position. When you have completed the reference mark search in the Manual operation mode, you then set the presets that will be used as the basis for machining the workpiece compliant to a dimensional drawing.

i Presetting in the Manual Operation mode is required in order to use the product in MDI mode.

The following sections describe how to measure positions and select the tools for simple machining operations in the Manual operation mode.

Activation



- ▶ Tap **Manual operation** in the main menu
- > The user interface for manual operation is displayed

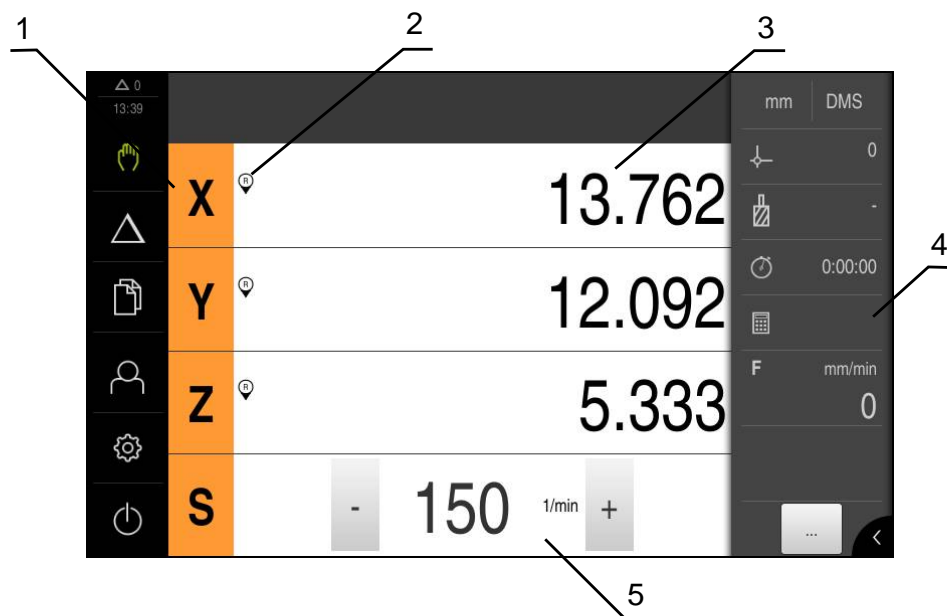

Figure 46: **Manual operation** menu

- 1 Axis key
- 2 Reference
- 3 Position display
- 4 Status bar
- 5 Spindle speed (machine tool)

11.2 Conducting the reference mark search

With the help of reference marks, the unit can assign axis positions of the encoder to the machine.

If no reference marks for the encoder are provided by a defined coordinate system, you need to perform a reference mark search before you start measuring.



If the unit is configured with the **Turning** application mode and a **spindle axis S**, then you must define an upper limit for the spindle speed prior to a possible machining operation.

Further information: "Defining the upper limit for the spindle speed (in the Turning application mode)", Page 191



If the reference mark search after unit start is active, then all of the unit's functions will be disabled until the reference mark search has been successfully completed.

Further information: "Reference marks (Encoder)", Page 252

If the reference mark search is active on the unit, then a wizard will ask you to traverse the reference marks of the axes.

- ▶ After logging in, follow the instructions of the wizard
- The Reference symbol stops blinking upon successful completion of the reference mark search

Further information: "Operating elements of the position display", Page 78

Further information: "Activating the reference mark search", Page 95

Starting the reference mark search manually

If the reference mark search was not performed on startup, you can start it manually later.



- ▶ Tap **Manual operation** in the main menu
- The user interface for manual operation is displayed
- ▶ Tap **Additional functions** in the status bar



- ▶ Tap **Reference marks**
- Existing reference marks are cleared
- The Reference symbol blinks
- ▶ Follow the instructions of the wizard
- The Reference symbol stops blinking upon successful completion of the reference mark search

11.3 Defining presets

You can define presets on a workpiece in the Manual Operation mode in the following ways:

- Probe a workpiece with a HEIDENHAIN KT 130 Edge Finder. Use this method to automatically enter the presets into the preset table.
- Probing a workpiece with a tool (touch-off). Use this method to define the respective tool position as a datum.



The setup engineer (**Setup**) may have already made settings in the datum table.

Further information: "Creating a preset table", Page 142



When touching the workpiece with a tool, the product uses the parameters stored in the tool table.

Further information: "Creating a tool table", Page 138

Requirement:

- A workpiece is clamped on the machine tool
- The reference mark search was successfully completed

11.3.1 Presetting by probing (in the Milling application mode)



- ▶ Tap **Manual operation** in the main menu
- The user interface for manual operation is displayed
- ▶ Tap **Additional functions** in the status bar



- ▶ Tap the desired function in the dialog under **Probing**:



- ▶ Probe edge

or



- ▶ Find centerline

or



- ▶ Find the circle center

- ▶ Select the inserted tool in the **Select the tool** dialog:

- ▶ When using a HEIDENHAIN KT 130 Edge Finder: Activate **Use touch probe**

- ▶ When using a tool:

- ▶ Deactivate **Use touch probe**

- ▶ Enter the desired value in the **Tool diameter** input field

or

- ▶ Select the corresponding tool from the tool table



- ▶ Tap **Confirm** in the wizard

- ▶ Follow the wizard's instructions for probing

- ▶ Keep in mind when probing:

- ▶ Move the edge finder toward the workpiece edge until the red LED on the edge finder lights up

or

- ▶ Move the tool until it touches the workpiece edge

- ▶ Confirm each step in the wizard

- ▶ Retract the edge finder or tool after the last probing operation

- The **Select preset** dialog appears after the last probing procedure

- ▶ Select the desired preset in the **Selected preset** input field:

- ▶ To overwrite an existing preset, select an entry from the preset table

- ▶ To add a new preset, enter a number that has not yet been assigned in the preset table

- ▶ Confirm the entry with **RET**

- ▶ Enter the desired value in the **Set position values** input field:

- ▶ Leave the input field empty to load the measured value

- ▶ To define a new value, enter the desired value

- ▶ Confirm the entry with **RET**



- ▶ Tap **Confirm** in the wizard

- The probed coordinate is loaded as preset

11.3.2 Presetting a position as datum

When manually machining a workpiece on a machine tool, traverse the axes using the handwheels. For simple machining operations, you can use the current position as a datum and perform simple position calculations.

- A workpiece is clamped on the machine tool
- The reference mark search was successfully completed

Setting the current position as zero point



- ▶ Move the tool manually to the desired position
- ▶ Hold down **Axis key**
- > The active preset in the preset table is overwritten with the current position
- > The active preset is applied as the new value
- ▶ Perform the desired machining operation

Defining the position values of the current position



- ▶ Move the tool manually to the desired position
- ▶ In the working space, tap **Axis key** or the position value
- ▶ Enter the desired position value
- ▶ Confirm the entry with **RET**
- > The position value is applied to the current position
- > The entered position value is linked with the current position and overwrites the active preset in the preset table
- > The active preset is applied as the new value
- ▶ Perform the desired machining operation

11.4 Creating a tool

In the Manual Operation mode, you can enter the tools you want to use into the tool table.



The setup engineer (**Setup**) may have already made the settings in the tool table.

Further information: "Creating a tool table", Page 138

- A workpiece is clamped on the machine tool
- The reference mark search was successfully completed

Milling application mode



- ▶ Tap **Tools** on the status bar
- > The **Tools** dialog appears



- ▶ Tap **Open table**
- > The **Tool table** dialog appears



- ▶ Tap **Add**
- ▶ Enter a name in the **Tool type** input field
- ▶ Confirm the entry with **RET**
- ▶ Tap the input fields one after the other, and enter the corresponding values
- ▶ Change the unit of measure in the selection menu, if required
- > The entered values are converted
- ▶ Confirm the entry with **RET**
- > The defined tool is added to the tool table
- ▶ To protect the entry for a tool from accidental changes or deletion, tap the **Lock** symbol next to the tool's entry
- > The symbol changes and the entry is locked



- ▶ Tap **Close**
- > The **Tool table** dialog is closed

11.5 Selecting a tool

The currently selected tool is displayed on the status bar. Here you can also access the tool table where you can select the tool you want to use. The associated tool parameters are applied automatically.

The product provides a tool radius compensation feature that enables you to directly enter the workpiece dimensions as specified in the drawing. During machining, the product will then automatically display a traverse path that is increased (R+) or decreased (R-) by the tool radius.



The setup engineer (**Setup**) may have already made the settings in the tool table.

Further information: "Creating a tool table", Page 138



- ▶ Tap **Tools** on the status bar
- > The **Tools** dialog appears
- ▶ Tap the tool you want to use



- ▶ Tap **Confirm**
- > The associated tool parameters are applied automatically
- > The selected tool is shown on the status bar
- ▶ Mount the desired tool on the machine tool

12

**Turning – Manual
operation**

12.1 Overview

This chapter describes the "Manual operation" mode and how to execute simple machining steps in this mode on a workpiece.

i Make sure that you have read and understood the "Basic Operation" chapter before carrying out the actions described below.
Further information: "Basic Operation", Page 57

Short description

By traversing the reference marks on the encoder scales, you make it possible to define an absolute position. When you have completed the reference mark search in the Manual operation mode, you then set the presets that will be used as the basis for machining the workpiece compliant to a dimensional drawing.

i Presetting in the Manual Operation mode is required in order to use the product in MDI mode.

The following sections describe how to measure positions and select the tools for simple machining operations in the Manual operation mode.

Activation



- ▶ Tap **Manual operation** in the main menu
- > The user interface for manual operation is displayed

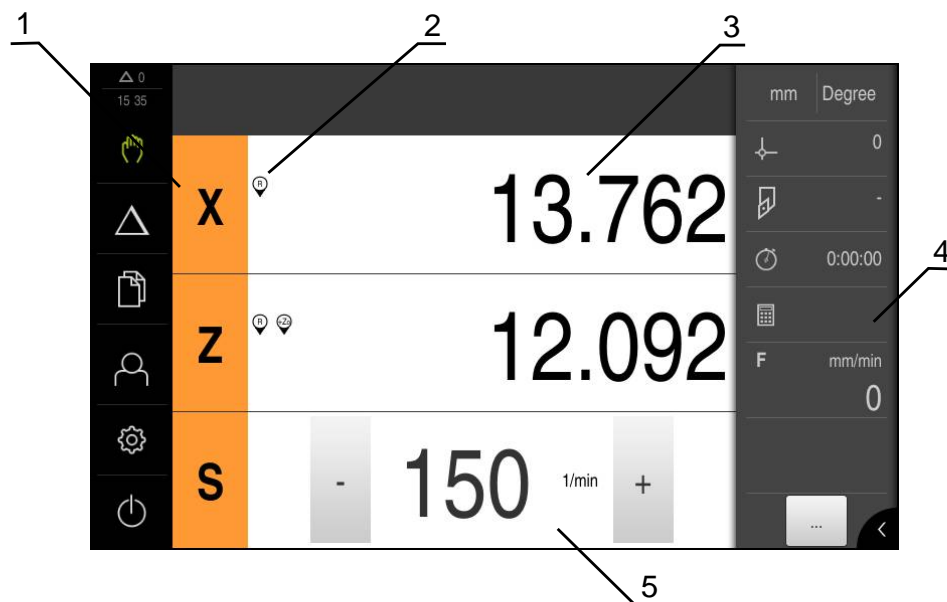

Figure 47: **Manual operation** menu

- 1 Axis key
- 2 Reference
- 3 Position display
- 4 Status bar
- 5 Spindle speed (machine tool)

12.2 Defining the upper limit for the spindle speed (in the Turning application mode)

If the unit is configured with the **Turning** application mode and a **spindle axis S**, then you must define an upper limit for the spindle speed prior to a possible machining operation.

For this purpose, the **Upper limit for spindle speed** appears after every switch-on.

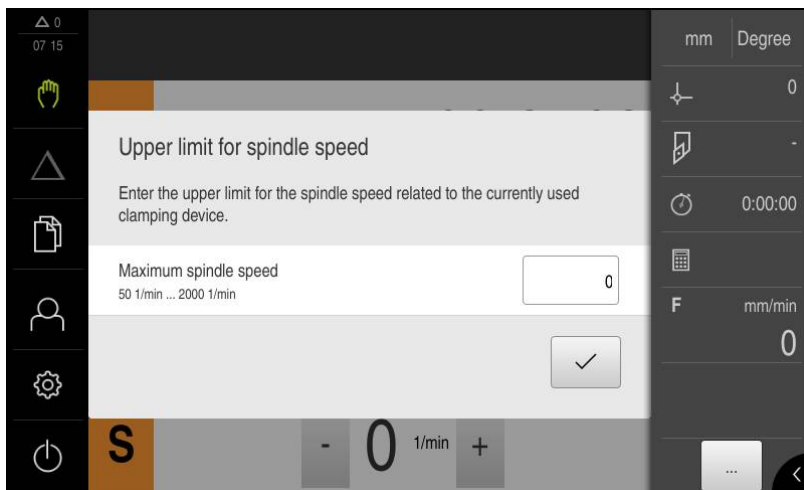

Figure 48: **Upper limit for spindle speed** dialog

- ▶ Tap the **Maximum spindle speed** input field
- ▶ Enter the upper limit for the spindle speed with respect to the currently used clamping equipment.
- ▶ Confirm the entry with **RET**
- ▶ Tap **Confirm**
- > The upper limit is now adopted by the unit
- > The **Upper limit for spindle speed** dialog is closed



12.3 Conducting the reference mark search

With the help of reference marks, the unit can assign axis positions of the encoder to the machine.

If no reference marks for the encoder are provided by a defined coordinate system, you need to perform a reference mark search before you start measuring.



If the unit is configured with the **Turning** application mode and a **spindle axis S**, then you must define an upper limit for the spindle speed prior to a possible machining operation.

Further information: "Defining the upper limit for the spindle speed (in the Turning application mode)", Page 191



If the reference mark search after unit start is active, then all of the unit's functions will be disabled until the reference mark search has been successfully completed.

Further information: "Reference marks (Encoder)", Page 252

If the reference mark search is active on the unit, then a wizard will ask you to traverse the reference marks of the axes.

- ▶ After logging in, follow the instructions of the wizard
- > The Reference symbol stops blinking upon successful completion of the reference mark search

Further information: "Operating elements of the position display", Page 78

Further information: "Activating the reference mark search", Page 95

Starting the reference mark search manually

If the reference mark search was not performed on startup, you can start it manually later.



- ▶ Tap **Manual operation** in the main menu
- > The user interface for manual operation is displayed
- ▶ Tap **Additional functions** in the status bar



- ▶ Tap **Reference marks**
- > Existing reference marks are cleared
- > The Reference symbol blinks
- ▶ Follow the instructions of the wizard
- > The Reference symbol stops blinking upon successful completion of the reference mark search

12.4 Presetting a position as datum

When manually machining a workpiece on a machine tool, traverse the axes using the handwheels. For simple machining operations, you can use the current position as a datum and perform simple position calculations.

- A workpiece is clamped on the machine tool
- The reference mark search was successfully completed

Setting the current position as zero point



- ▶ Move the tool manually to the desired position
- ▶ Hold down **Axis key**
- > The active preset in the preset table is overwritten with the current position
- > The active preset is applied as the new value
- ▶ Perform the desired machining operation

Defining the position values of the current position



- ▶ Move the tool manually to the desired position
- ▶ In the working space, tap **Axis key** or the position value
- ▶ Enter the desired position value
- ▶ Confirm the entry with **RET**
- > The position value is applied to the current position
- > The entered position value is linked with the current position and overwrites the active preset in the preset table
- > The active preset is applied as the new value
- ▶ Perform the desired machining operation

12.5 Adding a tool

In the Manual Operation mode, you can enter the tools you want to use into the tool table.



The setup engineer (**Setup**) may have already made the settings in the tool table.

Further information: "Creating a tool table", Page 138

- A workpiece is clamped on the machine tool
- The reference mark search was successfully completed

Turning application mode



- ▶ Tap **Tools** on the status bar
- > The **Tools** dialog appears



- ▶ Tap **Open table**
- > The **Tool table** dialog appears



- ▶ Tap **Add**
- ▶ Enter a name in the **Tool type** input field
- ▶ Confirm the entry with **RET**
- ▶ Tap the input fields one after the other, and enter the corresponding values
- ▶ Change the unit of measure in the selection menu, if required
- > The entered values are converted
- ▶ Confirm the entry with **RET**
- > The defined tool is added to the tool table
- ▶ To protect the entry for a tool from accidental changes or deletion, tap the **Lock** symbol next to the tool's entry
- > The symbol changes and the entry is locked



- ▶ Tap **Close**
- > The **Tool table** dialog is closed

12.6 Selecting a tool

The currently selected tool is displayed on the status bar. Here you can also access the tool table where you can select the tool you want to use. The associated tool parameters are applied automatically.



The setup engineer (**Setup**) may have already made the settings in the tool table.

Further information: "Creating a tool table", Page 138



- ▶ Tap **Tools** on the status bar
- > The **Tools** dialog appears
- ▶ Tap the tool you want to use



- ▶ Tap **Confirm**
- > The associated tool parameters are applied automatically
- > The selected tool is shown on the status bar
- ▶ Mount the desired tool on the machine tool

13

Milling – MDI mode

13.1 Overview

This chapter describes the "MDI (Manual Data Input)" mode of operation and how to execute machining steps in single blocks in this mode.

i Make sure that you have read and understood the "Basic Operation" chapter before carrying out the actions described below.

Further information: "Basic Operation", Page 57

Short description

The MDI mode enables you to execute precisely one single machining block. The values to be entered into the input fields can be taken directly from a properly dimensioned production drawing.

i Before you can use the product in the MDI mode, the presets must be set in the Manual Operation mode.

Further information: "Defining presets", Page 184



▶ Tap **MDI** in the main menu



▶ Tap **Create** on the status bar

> The user interface for the MDI mode is displayed

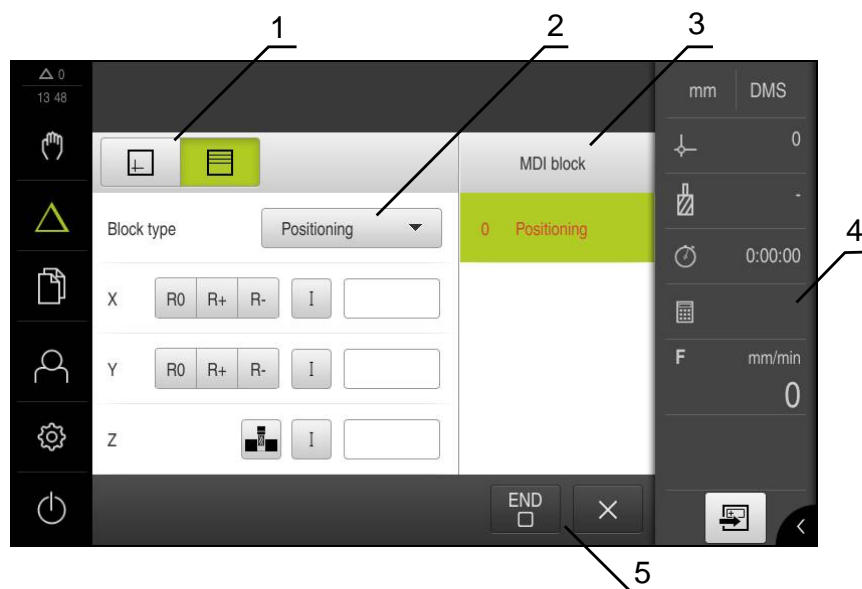

Figure 49: **MDI** menu

- 1 View bar
- 2 Block parameters
- 3 MDI block
- 4 Status bar
- 5 Block tools

13.2 Block types

You can use the following block types for machining in the MDI mode:

- Positioning functions
- Machining patterns

13.2.1 Positioning





You can manually define position values for positioning. Depending on the configuration of the connected machine tool, you can then move the tool to these positions either automatically or manually.

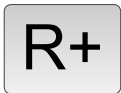

In the appropriate input fields you can load the current axis position with **Actual position capture**.

The following parameters are available:

Positioning block

Parameter	Description
	Tool radius compensation disabled (default setting)
	Positive tool radius compensation; the traverse path is increased by the tool radius (outside contour)
	Negative tool radius compensation; the traverse path is decreased by the tool radius (inside contour)
	Incremental position value, i.e. the position value is referenced to the actual position
	Only for the Z axis: Drill through without position value specification

13.2.2 Machining patterns

You can define various machining patterns to machine complex shapes. From the data you enter, the product calculates the geometry of the machining patterns and optionally displays them in the simulation window.



Before defining a machining pattern, you must

- Define a suitable tool in the tool table
- Select the tool on the status bar

Further information: "Creating a tool table", Page 138



In the appropriate input fields you can load the current axis position with **Actual position capture**.

Bolt hole circle block

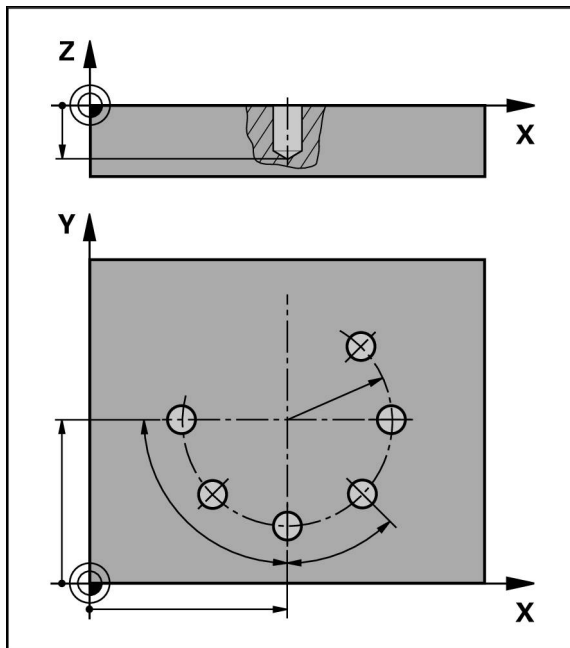
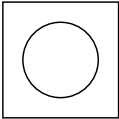



Figure 50: Schematic display of the bolt hole circle block

Parameter	Description
Number of holes	Number of holes
X coordinate of center	Center of the bolt hole arc in the X plane
Y coordinate of center	Center of the bolt hole arc in the Y plane
Radius	Radius of the bolt hole arc
Starting angle	Angle of the 1st hole of the bolt hole arc
Stepping angle	Angle of the circle segment Default: bolt hole circle
	
Depth	Target depth for drilling in the Z plane Default: drilling through-holes
	

Row of holes block

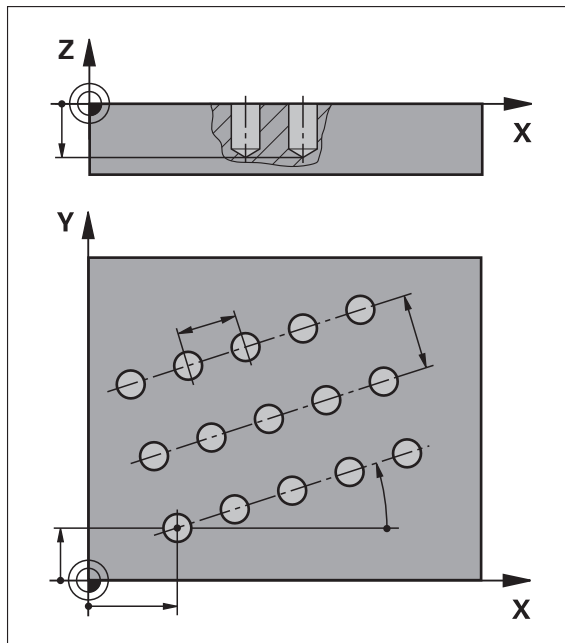

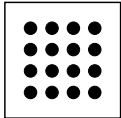
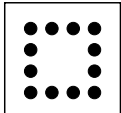

Figure 51: Schematic display of the row of holes block

Parameter	Description
X coordinate of 1st hole	1st hole of the linear hole pattern in the X plane
Y coordinate of 1st hole	1st hole of the linear hole pattern in the Y plane
Holes per row	Number of holes per row
Hole spacing	Spacing or offset between the individual holes of a row
Angle	Rotation angle of the row of holes
Depth	Target depth for drilling in the Z plane Default: drilling through-holes
	
Number of rows	Number of rows of holes in the linear hole pattern
Row spacing	Spacing between the individual rows of holes
Fill mode	Distribution of holes
	<ul style="list-style-type: none"> ■ All holes ■ Frame of holes
	

Rectangular pocket block

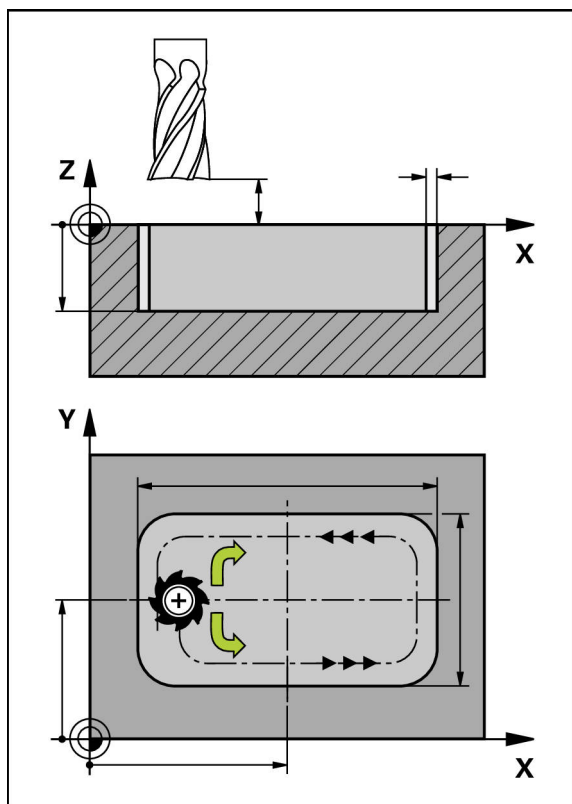

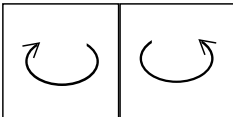

Figure 52: Schematic display of the rectangular pocket block

Parameter	Description
Clearance height	Starting depth for milling in the tool axis
Depth	Target depth for milling in the tool axis Default: drill through
	
X coordinate of center	Center of the rectangular pocket in the X plane
Y coordinate of center	Center of the rectangular pocket in the Y plane
Side length in X	Length of the rectangular pocket in the X-axis direction
Side length in Y	Length of the rectangular pocket in the Y-axis direction
Direction	Direction in which the rectangular pocket is roughed out (clockwise or counterclockwise) Default: counterclockwise
	
Finishing allowance	Amount of material that is to be left remaining around the rectangular pocket and will be removed in the last pass

When machining a rectangular pocket in MDI and Program Run modes of operation, the following applies:

- Approaching the starting position is at clearance height at rapid traverse
- If a target depth was defined, positioning is at **Clearance height** at the end of machining

13.3 Executing blocks

You can select a positioning function or machining pattern, and execute that block.



If enabling signals are missing, the running program is halted and the drives of the machine are stopped.

Further information: Manufacturer's documentation for the machine

Executing blocks



- ▶ Tap **Create** on the status bar
- > A new block is displayed
- or
- > The last programmed MDI block with all parameters is loaded
- ▶ Select the desired block type in the **Block type** drop-down list



- ▶ To load the current axis position, tap **Actual position capture** in the appropriate input fields
- ▶ Confirm each entry with **RET**



- ▶ To run the block, tap **END**
- > The positioning aid is displayed
- > If the simulation window is active, the current block is visualized
- > User intervention may be required, depending on the block; the wizard will display the relevant instructions



- ▶ Follow the instructions of the wizard
- ▶ With multi-step blocks, such as machining patterns in wizards, tap **Next** to proceed to the next step

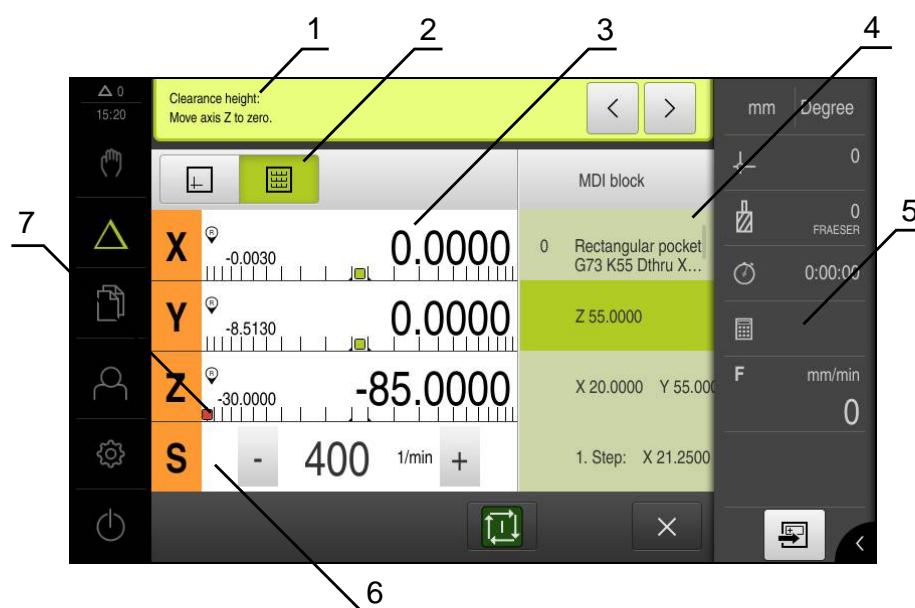

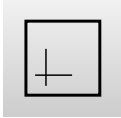

Figure 53: Example of a block in the **MDI** mode

- 1 Wizard
- 2 View bar
- 3 Distance-to-go display
- 4 MDI block
- 5 Status bar
- 6 Spindle speed (machine tool)
- 7 Positioning aid

13.4 Using the simulation window

You can display a visualization of the selected block in the optional simulation window.

The following options are available on the view bar:

Operating element	Function
	Graphic Display of simulation and blocks
	Position Display of parameters (position values for program run, if required) and blocks

13.4.1 Depiction as contour view

The simulation window displays a contour view. The contour view provides the necessary feedback for precisely positioning the tool or for following a contour along the machining plane.

The contour view uses the following colors (defaults):

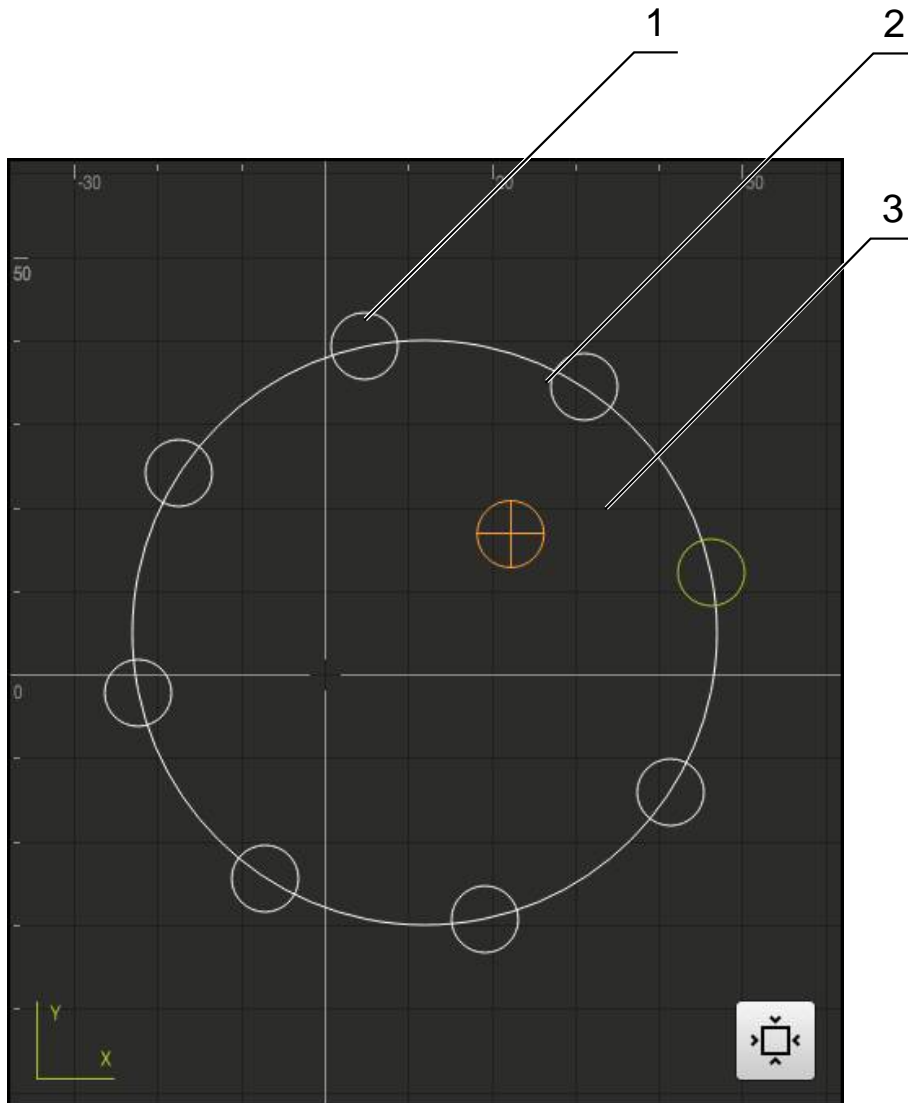

Figure 54: Simulation window with contour view

- 1 Machining pattern (white)
- 2 Current block or machining position (green)
- 3 Tool contour, tool position and tool track (orange)

Activating the simulation window



- ▶ Tap **Graphic**
- > The simulation window for the currently selected block appears

13.5 Working with the positioning aid

During positioning to the next nominal position, the product assists you by displaying a graphical positioning aid ("traversing to zero"). A scale is shown underneath each axis you traverse to zero. The graphic positioning aid is a small square that symbolizes the tool center.

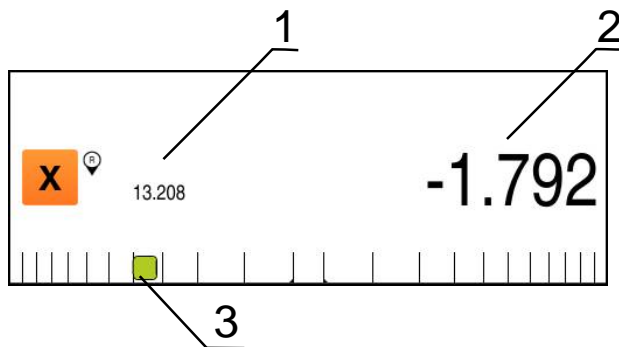

Figure 55: **Distance to go with position** view with graphic positioning aid

- 1 Actual value
- 2 Distance-to-go
- 3 Positioning aid (tool center)

The positioning aid moves across the measuring scale when the tool center is located within a range of ± 5 mm of the nominal position. The color also changes in the following way:

Display of positioning aid	Meaning
Red	The tool center is moving away from the nominal positions
Green	The tool center is moving toward the nominal position

13.6 Executing an MDI block with Scaling factor

If a scaling factor is activated for one or more axes, then this scaling factor is multiplied with the stored nominal position during execution of an MDI block. By this means, you can mirror and scale an MDI block.

You can activate a scaling factor in the quick access menu.

Further information: "Adjusting settings in the quick access menu", Page 83

Example:

The following **MDI block** is programmed:

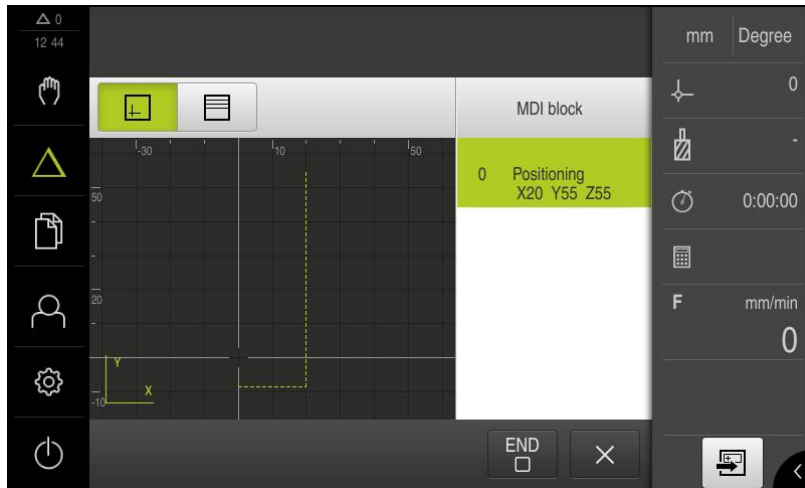

Figure 56: Example – MDI block

A **Scaling factor** of **-0.5** is activated for the **X** axis. The following **MDI block** will therefore be executed:



Figure 57: Example – Execution of an MDI block with scaling factor

- i** If the calculated dimensions cannot be attained with the selected tool, then the execution of the MDI block is aborted.
- i** The scaling factor cannot be changed during execution of an MDI block.

14

**Turning –
MDI mode**

14.1 Overview

This chapter describes the "MDI (Manual Data Input)" mode of operation and how to execute machining steps in single blocks in this mode.



Make sure that you have read and understood the "Basic Operation" chapter before carrying out the actions described below.

Further information: "Basic Operation", Page 57

Short description

The MDI mode enables you to execute precisely one single machining block. The values to be entered into the input fields can be taken directly from a properly dimensioned production drawing.



Before you can use the product in the MDI mode, the presets must be set in the Manual Operation mode.

Further information: "Defining presets", Page 184



▶ Tap **MDI** in the main menu



▶ Tap **Create** on the status bar

> The user interface for the MDI mode is displayed

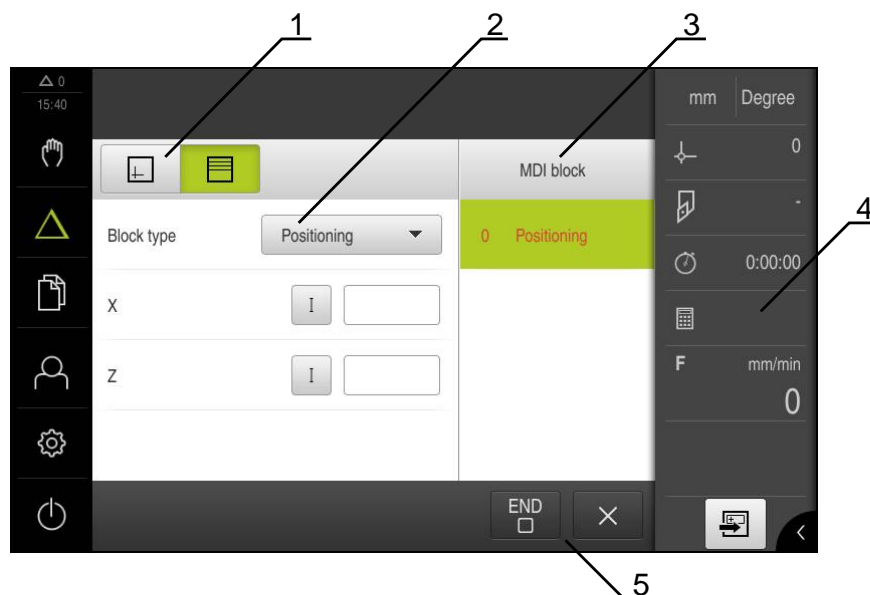

Figure 58: **MDI** menu

- 1 View bar
- 2 Block parameters
- 3 MDI block
- 4 Status bar
- 5 Block tools

14.2 Defining the upper limit for the spindle speed (in the Turning application mode)

If the unit is configured with the **Turning** application mode and a **spindle axis S**, then you must define an upper limit for the spindle speed prior to a possible machining operation.

For this purpose, the **Upper limit for spindle speed** appears after every switch-on.

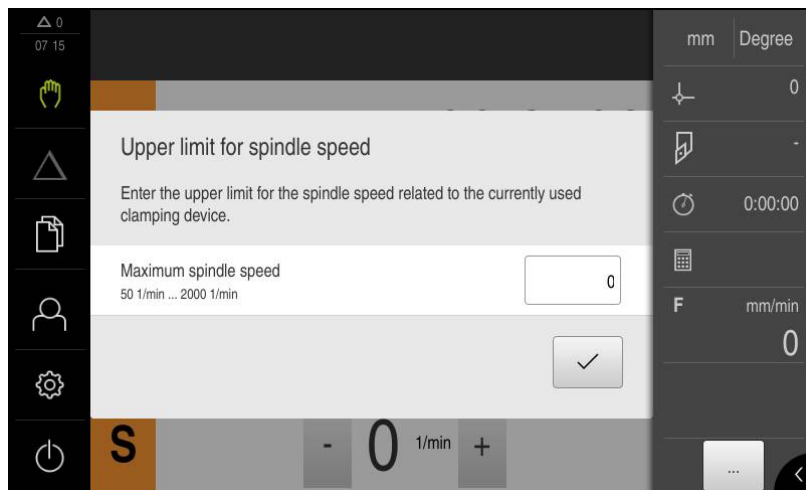

Figure 59: **Upper limit for spindle speed** dialog

- ▶ Tap the **Maximum spindle speed** input field
- ▶ Enter the upper limit for the spindle speed with respect to the currently used clamping equipment.
- ▶ Confirm the entry with **RET**
- ▶ Tap **Confirm**
- > The upper limit is now adopted by the unit
- > The **Upper limit for spindle speed** dialog is closed



14.3 Block types

You can use the following block types for machining in the MDI mode:

- Positioning functions

14.3.1 Positioning

You can manually define position values for positioning. Depending on the configuration of the connected machine tool, you can then move the tool to these positions either automatically or manually.



In the appropriate input fields you can load the current axis position with **Actual position capture**.

The following parameters are available:

Positioning block

Parameter	Description
	Incremental position value, i.e. the position value is referenced to the actual position

14.4 Executing blocks

You can select a positioning function and execute this block.



If enabling signals are missing, the running program is halted and the drives of the machine are stopped.

Further information: Manufacturer's documentation for the machine

Executing blocks



- ▶ Tap **Create** on the status bar
- > A new block is displayed
- or
- > The last programmed MDI block with all parameters is loaded
- ▶ Select the desired block type in the **Block type** drop-down list



- ▶ To load the current axis position, tap **Actual position capture** in the appropriate input fields
- ▶ Confirm each entry with **RET**



- ▶ To run the block, tap **END**
- > The positioning aid is displayed
- > If the simulation window is active, the current block is visualized
- > User intervention may be required, depending on the block; the wizard will display the relevant instructions



- ▶ Follow the instructions of the wizard
- ▶ With multi-step blocks in wizards, tap **Next** to proceed to the next step

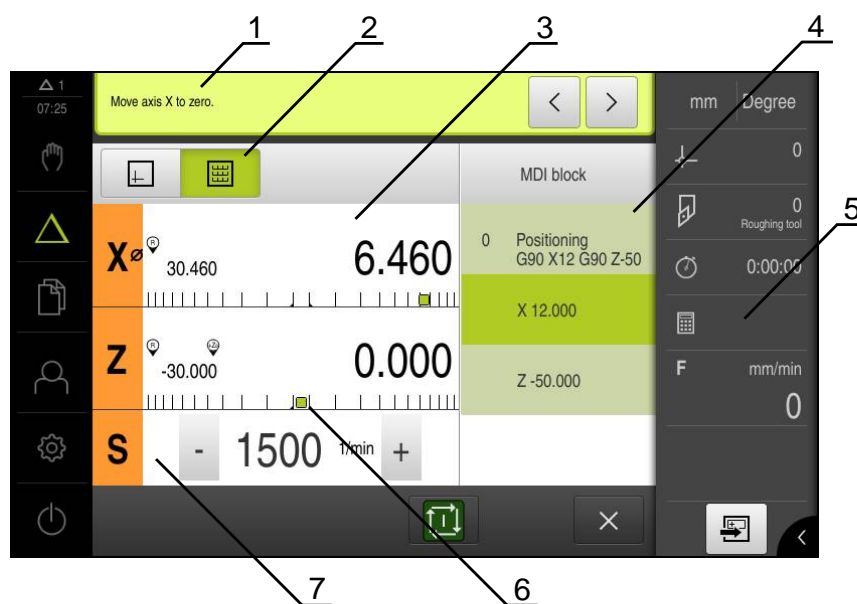

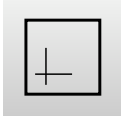

Figure 60: Example of a block in the **MDI** mode

- 1 Wizard
- 2 View bar
- 3 Distance-to-go display
- 4 MDI block
- 5 Status bar
- 6 Positioning aid
- 7 Spindle speed (machine tool)

14.5 Using the simulation window

You can display a visualization of the selected block in the optional simulation window.

The following options are available on the view bar:

Operating element	Function
	Graphic Display of simulation and blocks
	Position Display of parameters (position values for program run, if required) and blocks

14.5.1 Depiction as contour view

The simulation window displays a contour view. The contour view provides the necessary feedback for precisely positioning the tool or for following a contour along the machining plane.

The contour view uses the following colors (defaults):

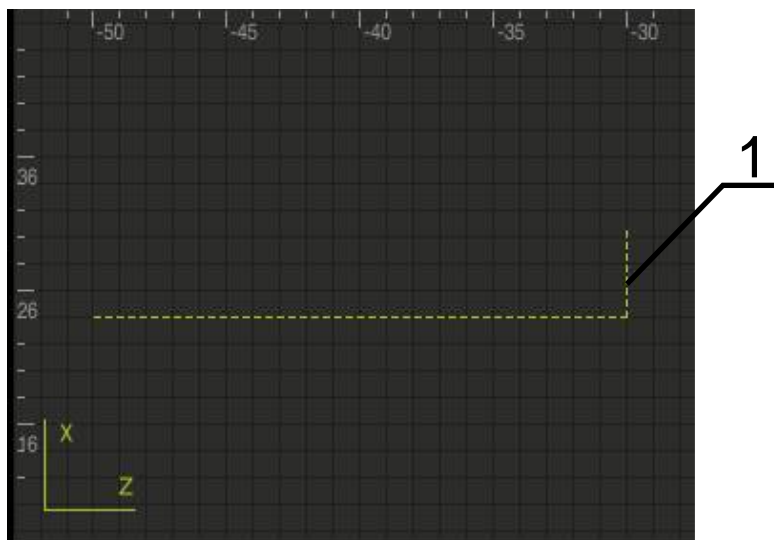

Figure 61: Simulation window with contour view

1 Current block or machining position (green)

Activating the simulation window



- ▶ Tap **Graphic**
- > The simulation window for the currently selected block appears

14.6 Working with the positioning aid

During positioning to the next nominal position, the product assists you by displaying a graphical positioning aid ("traversing to zero"). A scale is shown underneath each axis you traverse to zero. The graphic positioning aid is a small square that symbolizes the tool center.

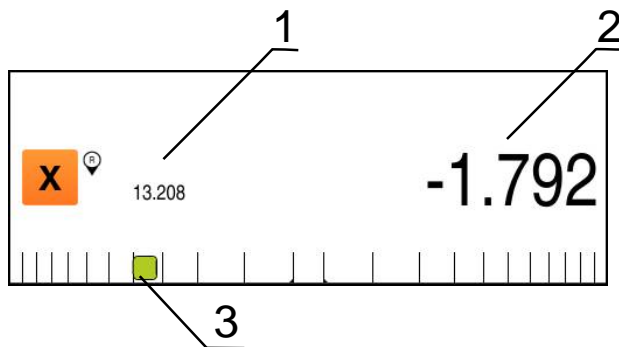

Figure 62: **Distance to go with position** view with graphic positioning aid

- 1 Actual value
- 2 Distance-to-go
- 3 Positioning aid (tool center)

The positioning aid moves across the measuring scale when the tool center is located within a range of ± 5 mm of the nominal position. The color also changes in the following way:

Display of positioning aid	Meaning
Red	The tool center is moving away from the nominal positions
Green	The tool center is moving toward the nominal position

14.7 Executing an MDI block with Scaling factor

If a scaling factor is activated for one or more axes, then this scaling factor is multiplied with the stored nominal position during execution of an MDI block. By this means, you can mirror and scale an MDI block.

You can activate a scaling factor in the quick access menu.

Further information: "Adjusting settings in the quick access menu", Page 83

Example:

The following **MDI block** is programmed:

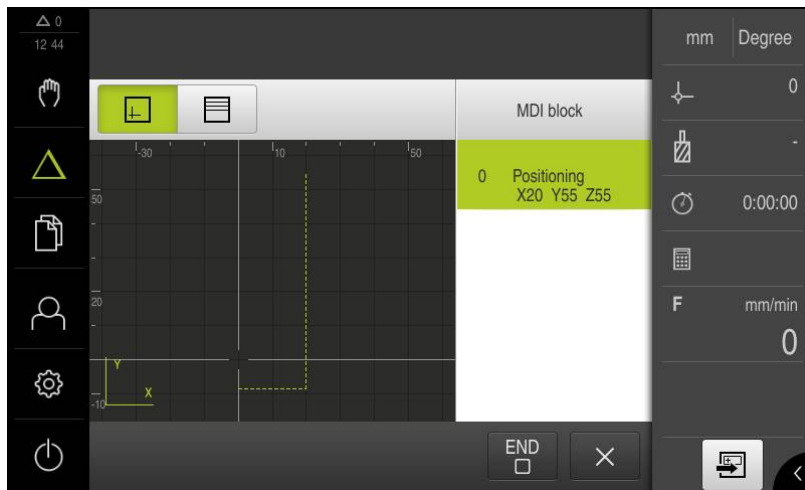

Figure 63: Example – MDI block

A **Scaling factor** of **-0.5** is activated for the **X** axis. The following **MDI block** will therefore be executed:



Figure 64: Example – Execution of an MDI block with scaling factor

- i** If the calculated dimensions cannot be attained with the selected tool, then the execution of the MDI block is aborted.
- i** The scaling factor cannot be changed during execution of an MDI block.

15

File Management

15.1 Overview

This chapter describes the **File management** menu and its functions.



Make sure that you have read and understood the "Basic Operation" chapter before carrying out the actions described below.

Further information: "Basic Operation", Page 57

Short description

The **File management** menu shows an overview of the files stored in the unit's memory.

Any connected USB mass storage devices (FAT32 format) or available network drives are shown in the list of storage locations. The USB mass storage devices and the network drives are displayed with their names or drive designations.

Activation



- ▶ Tap **File management** in the main menu
- The user interface for file management is displayed

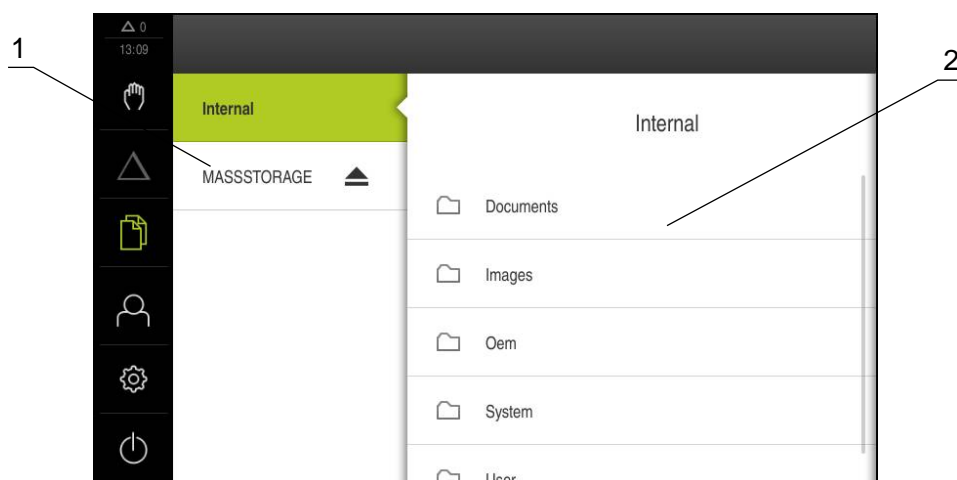

Figure 65: **File management** menu

- 1 List of available storage locations
- 2 List of folders in the selected storage location

15.2 File types

In the **File management** menu you can edit the following file types:

Type	Use	Manage	View	Open	Print
*.mcc	Configuration files	✓	–	–	–
*.dro	Firmware files	✓	–	–	–
*.svg, *.ppm	Image files	✓	–	–	–
*.jpg, *.png, *.bmp	Image files	✓	✓	–	–
*.csv	Text files	✓	–	–	–
*.txt, *.log, *.xml	Text files	✓	✓	–	–
*.pdf	PDF files	✓	✓	–	✓

15.3 Managing folders and files

Folder structure

In the **File management** menu, the files in the **Internal** storage location are saved in the following folders:

Folders	Application
Documents	Document files with instructions and service addresses
Images	Image files
Oem	Files for configuring the OEM bar (visible only to OEM users)
System	Audio files and system files
User	User data

Creating a new folder



- ▶ Touch the icon of the folder in which you want to create a new folder, and drag it to the right
- > The operating elements are displayed
- ▶ Tap **Create a new folder**
- ▶ Tap the input field in the dialog and enter a name for the new folder
- ▶ Confirm entry with **RET**
- ▶ Tap **OK**
- > A new folder is created

Moving a folder



- ▶ Touch the icon of the folder you want to move, and drag it to the right
- > The operating elements are displayed
- ▶ Tap **Move to**
- ▶ In the dialog, select the folder to which you want to move the folder
- ▶ Tap **Select**
- > The folder is moved

Copying a folder



- ▶ Touch the icon of the folder you want to copy, and drag it to the right
- > The operating elements are displayed
- ▶ Tap **Copy to**
- ▶ In the dialog, select the folder to which you want to copy the folder
- ▶ Tap **Select**
- > The folder is copied



If you copy a folder to the folder it is stored in, the suffix "_1" is appended to the name of the copied folder.

Renaming a folder



- ▶ Touch the icon of the folder you want to rename, and drag it to the right
- > The operating elements are displayed
- ▶ Tap **Rename folder**
- ▶ Tap the input field in the dialog and enter a name for the new folder
- ▶ Confirm the entry with **RET**
- ▶ Tap **OK**
- > The folder is renamed

Moving a file



- ▶ Touch the icon of the file you want to move, and drag it to the right
- > The operating elements are displayed
- ▶ Tap **Move to**
- ▶ In the dialog, select the folder to which you want to move the file
- ▶ Tap **Select**
- > The file is moved

Copying a file



- ▶ Touch the icon of the file you want to copy, and drag it to the right
- > The operating elements are displayed
- ▶ Tap **Copy to**
- ▶ In the dialog, select the folder to which you want to copy the file
- ▶ Tap **Select**
- > The file is copied



If you copy a file to the folder it is stored in, the suffix "_1" is appended to the name of the copied file.

Renaming a file



- ▶ Touch the icon of the file you want to rename, and drag it to the right
- > The operating elements are displayed
- ▶ Tap **Rename file**
- ▶ Tap the input field in the dialog and enter a name for the new file
- ▶ Confirm the entry with **RET**
- ▶ Tap **OK**
- > The file is renamed

Deleting a folder or file

The folders and files you delete will be permanently deleted and cannot be recovered. If you delete a folder, all subfolders and files contained in that folder will also be deleted.



- ▶ Touch the icon of the folder or file you want to delete, and drag it to the right
- > The operating elements are displayed
- ▶ Tap **Delete selection**
- ▶ Tap **Delete**
- > The folder or file is deleted

15.4 Opening and viewing files

Viewing files



- ▶ Tap **File management** in the main menu
- ▶ Navigate to the storage location of the desired file
- ▶ Tap the file
- > A preview image (only for PDF and image files) as well as information about the file are displayed

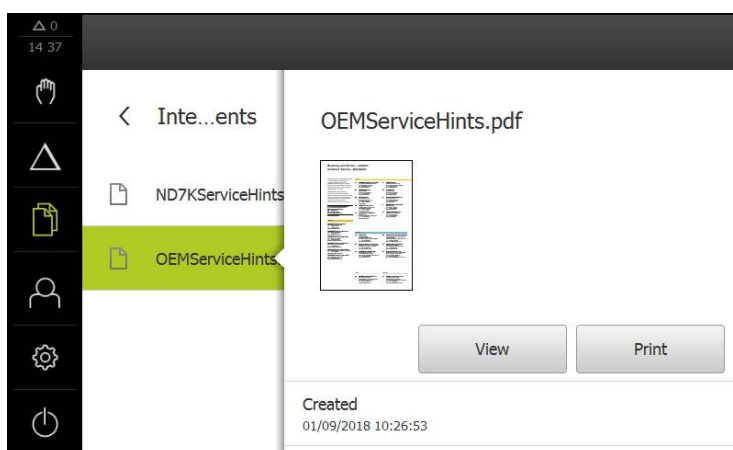

Figure 66: **File management** menu with preview image and file information

- ▶ Tap **View**
- > The file contents are displayed
- ▶ Tap **Close** to close the view



In this view, you can print PDF files on the printer configured in the product by tapping **Print**.

15.5 Exporting files

You can export files to an external USB mass storage device (FAT32-Format) or to the network drive. You can either copy or move the files:

- If you copy files, duplicates of the files will remain stored in the product
- If you move files, the files will be deleted in the product



- ▶ Tap **File management** in the main menu
- ▶ In the **Internal** storage location, navigate to the file you want to export
- ▶ Drag the icon of the file to the right
- > The operating elements are displayed



- ▶ To copy the file, tap **Copy file**



- ▶ To move the file, tap **Move file**
- ▶ In the dialog, select the storage location to which you want to export the file
- ▶ Tap **Select**
- > The file is exported to the USB mass storage device or the network drive

Safely removing a USB mass storage device



- ▶ Tap **File management** in the main menu
- ▶ Navigate to the list of storage locations
- ▶ Tap **Safely remove**



- > The message **The storage medium can be removed now.** appears
- ▶ Disconnect the USB mass storage device

15.6 Importing files

You can import files from a USB mass storage device (FAT32-Format) or a network drive into the product. You can either copy or move the files:

- If you copy files, duplicates of the files will remain on the USB mass storage device or the network drive
- If you move files, the files will be deleted from the USB mass storage device or the network drive



- ▶ Tap **File management** in the main menu
- ▶ On the USB mass storage device or network drive, navigate to the file you want to import
- ▶ Drag the icon of the file to the right
- > The operating elements are displayed



- ▶ To copy the file, tap **Copy file**



- ▶ To move the file, tap **Move file**
- ▶ In the dialog, select the storage location to which you want to save the file
- ▶ Tap **Select**
- > The file is stored on the product

Safely removing a USB mass storage device



- ▶ Tap **File management** in the main menu
- ▶ Navigate to the list of storage locations
- ▶ Tap **Safely remove**



- > The message **The storage medium can be removed now.** appears
- ▶ Disconnect the USB mass storage device

16

Settings

16.1 Overview

This chapter describes the setting options and the associated settings parameters for the product.

The basic setting options and settings parameters for commissioning and product setup are outlined in the respective chapters:

Further information: "Commissioning", Page 91

Further information: "Setup", Page 119

Short description



Depending on the type of user that is logged in to the product, settings and settings parameters can be edited and changed (edit permission).

If a user logged in to the product has no edit permission for a setting or an settings parameter, the setting or settings parameter is grayed out and cannot be opened or edited.

Function	Description
General	General settings and information
Sensors	Configuration of sensors and sensor-dependent functions
Interfaces	Configuration of interfaces and network drives
User	Configuration of users
Axes	Configuration of connected encoders and error compensation
Service	Configuration of service functions and information

Activation



- ▶ Tap **Settings** in the main menu

16.1.1 Overview of the Settings menu

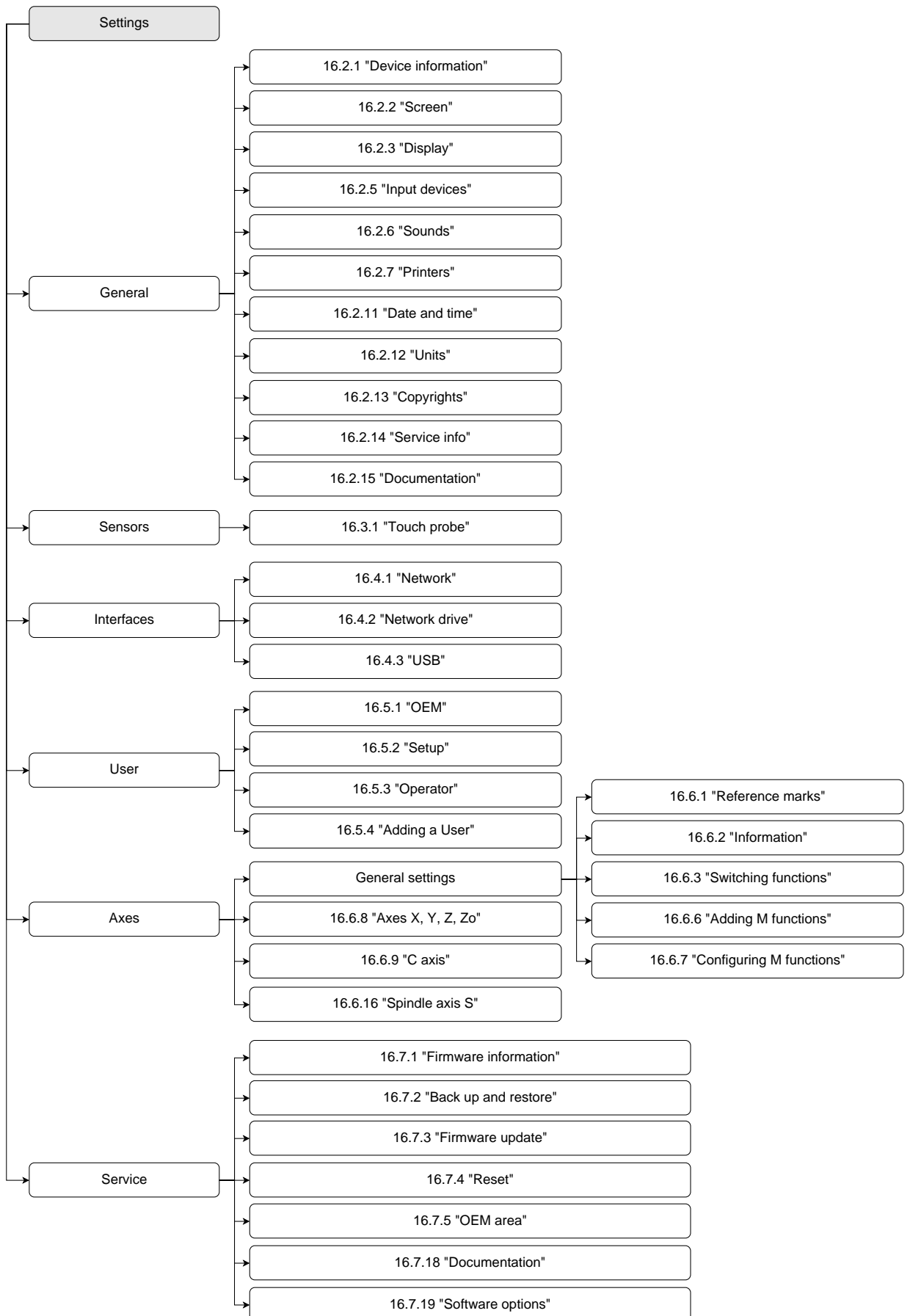

16.2 General

This chapter describes settings for configuring the operation and display and for setting up printers.

16.2.1 Device information

Path: **Settings ► General ► Device information**

The overview displays basic information about the software.

Parameter	Displays the information
Product designation	Product designation of the product
Part number	ID number of the unit
Serial number	Serial number of the product
Firmware version	Version number of the firmware
Firmware built on	Firmware creation date
Last firmware update on	Date of most recent firmware update
Free memory space	Free memory space in the internal storage location Internal
Free working memory (RAM)	Free RAM on the system
Number of unit starts	Number of times the product was started up with the current firmware
Operating time	Operating time of the product with the current firmware





16.2.2 Screen

Path: **Settings ► General ► Screen**

Parameter	Explanation
Brightness	Brightness of the screen <ul style="list-style-type: none"> ■ Setting range: 1 % ... 100 % ■ Default setting: 85 %
Energy-save-mode timeout	Time until energy-save mode is activated <ul style="list-style-type: none"> ■ Setting range: 0 min ... 120 min If the value is set to 0, the energy-save mode is deactivated ■ Default setting: 30 minutes
Quit the energy saving mode	Required actions to reactivate the screen <ul style="list-style-type: none"> ■ Tap and drag: Touch the touchscreen and drag the arrow upwards from the lower edge ■ Tap: Touch the touchscreen ■ Tap or axis movement: Touch the touchscreen or move the axis ■ Default setting: Tap and drag

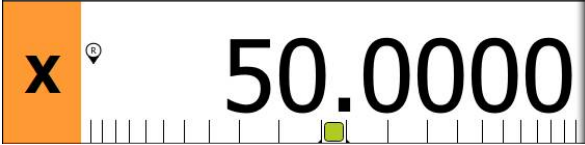
16.2.3 Display

Path: Settings ► General ► Display

Parameter	Explanation
Position display	<p>Configuration of the position display in MDI mode. The configuration also determines the actions specified by the wizards MDI mode:</p> <ul style="list-style-type: none"> ■ Position with distance to go – the wizard requests traversing the axis to the displayed position. ■ Distance to go with position – the wizard requests traversing the axis to 0 and a positioning aid is shown. <p>Settings:</p> <ul style="list-style-type: none"> ■ Position: The position is displayed large  <ul style="list-style-type: none"> ■ Position with distance to go: The position is displayed large and the distance to go is displayed small  <ul style="list-style-type: none"> ■ Distance to go with position: The distance to go is displayed large and the position is displayed small  <ul style="list-style-type: none"> ■ Default setting: Distance to go with position
Position values	<p>The position values can describe the actual values or nominal values of the axes.</p> <p>Settings:</p> <ul style="list-style-type: none"> ■ Actual value ■ Nominal value ■ Default setting: Actual value
Distance-to-go indicator	<p>Display of the distance-to-go indicator in MDI mode</p>  <ul style="list-style-type: none"> ■ Settings: ON or OFF ■ Default value: ON
Digits before the decimal point for size-adjusted axis display	<p>The number of integer places indicates the size at which the position values are displayed. If the number of integer values is exceeded, then the display is reduced in size so that the integers can be shown.</p> <ul style="list-style-type: none"> ■ Setting range: 0 ... 6 ■ Default value: 3

Parameter	Explanation
Simulation window	Configuration of the simulation window for MDI mode . Further information: "Simulation window", Page 230
Radial machining axes	Display of the radial machining axes in the Turning application mode Settings: <ul style="list-style-type: none"> ■ Radius ■ Diameter ■ Default value: Radius

16.2.4 Simulation window

Path: **Settings ► General ► Display ► Simulation window**

Parameter	Explanation
Line thickness of tool position	Line thickness for displaying the tool position <ul style="list-style-type: none"> ■ Settings: Standard or Bold ■ Default value: Standard
Color of tool position	Definition of the color for displaying the tool position <ul style="list-style-type: none"> ■ Setting range: Color scale ■ Default setting: Orange
Line thickness of current contour element	Line thickness for displaying the current contour element <ul style="list-style-type: none"> ■ Settings: Standard or Bold ■ Default value: Standard
Color of current contour element	Definition of the color for displaying the current contour element <ul style="list-style-type: none"> ■ Setting range: Color scale ■ Default setting: Green
Tool path	Use of the tool track <ul style="list-style-type: none"> ■ Settings: ON or OFF ■ Default value: ON
Horizontal alignment	Horizontal orientation of the coordinate system in the simulation window Settings: <ul style="list-style-type: none"> ■ Rightward: values increase to the right ■ Leftward: values increase to the left ■ Default value: Rightward
Vertical alignment	Vertical orientation of the coordinate system in the simulation window Settings: <ul style="list-style-type: none"> ■ Upward: values increase in the upward direction ■ Downward: values increase in the downward direction ■ Default value: Upward



The **Undo** buttons enable the color definitions of the simulation window to be reset to factory settings.

16.2.5 Input devices

Path: **Settings ► General ► Input devices**

Parameter	Explanation
Mouse substitute for multitouch gestures	<p>Specifies whether mouse operation should replace operation using the touchscreen (multitouch)</p> <p>Settings:</p> <ul style="list-style-type: none"> ■ Auto (until first multitouch): Touching the touchscreen causes mouse deactivation ■ On (no multitouch): Operation only possible with the mouse, the touchscreen is deactivated ■ Off (only multitouch): Operation only possible with the touchscreen, the mouse is deactivated ■ Default setting: Auto (until first multitouch)
USB keyboard layout	<p>If a USB keyboard is connected:</p> <ul style="list-style-type: none"> ■ Language selection of the keyboard assignment

16.2.6 Sounds

Path: **Settings ► General ► Sounds**

The available sounds are grouped into categories. The sounds differ within a category.

Parameter	Explanation
Speaker	<p>Use of the built-in speaker on the rear panel of the product</p> <ul style="list-style-type: none"> ■ Settings: ON or OFF ■ Default setting: ON
Speaker volume	<p>Volume of the product's speaker</p> <ul style="list-style-type: none"> ■ Setting range: 0 % ... 100 % ■ Default setting: 50 %
Message and Error	<p>Sound to be played when a message is displayed</p> <p>When you select a setting, the associated sound is played</p> <ul style="list-style-type: none"> ■ Settings: Standard, Guitar, Robot, Outer space, No sound ■ Default setting: Standard
Touch tone	<p>Sound to be played when using a touch element</p> <p>When you select a setting, the associated sound is played</p> <ul style="list-style-type: none"> ■ Settings: Standard, Guitar, Robot, Outer space, No sound ■ Default setting: Standard

16.2.7 Printers

Path: **Settings ► General ► Printers**

Parameters	Explanation
Default printer	List of printers configured on the product
Properties	Settings of the selected default printer Further information: "Properties", Page 232
Add printer	Adds a USB printer or Network printer Further information: "Add printer", Page 233
Remove printer	Removes a USB printer or Network printer connected to the product Further information: "Remove printer", Page 233

16.2.8 Properties

Path: **Settings ► General ► Printers ► Properties**

Parameters	Explanation
Resolution	Print resolution in dpi <ul style="list-style-type: none"> ■ The setting range and default setting depend on the printer type
Paper size	Specification of paper size and dimensions <ul style="list-style-type: none"> ■ The setting range and default setting depend on the printer type
Feed tray	Specification of the paper feeder <ul style="list-style-type: none"> ■ The setting range and default setting depend on the printer type
Type of paper	Designation of the paper type <ul style="list-style-type: none"> ■ The setting range and default setting depend on the printer type
Duplex printing	Options for duplex printing <ul style="list-style-type: none"> ■ The setting range and default setting depend on the printer type
Color/Black and white	Specification of the printing mode <ul style="list-style-type: none"> ■ The setting range and default setting depend on the printer type

16.2.9 Add printer

Path: **Settings ► General ► Printers ► Add printer**

The following parameters are available for **USB printer** and **Network printer**.

Parameters	Explanation
Located printers	Printers detected automatically on the (USB or network) port of the product
Name	Arbitrary printer name for easy identification <div style="border: 1px solid black; padding: 5px; margin-top: 10px;">  The text must not contain slashes ("/"), hash characters ("#") or spaces. </div>
Description	General printer description (optional, arbitrary)
Location	General location description (optional, arbitrary)
Connection	Type of printer connection
Select the driver	Selection of the appropriate driver for the printer

16.2.10 Remove printer

Path: **Settings ► General ► Printers ► Remove printer**

Parameters	Explanation
Printers	List of printers configured on the product
Type	Shows the type of the configured printer
Location	Shows the location of the configured printer
Connection	Shows the connection of the configured printer
Remove the selected printer	Deletes the configured printer from the product

16.2.11 Date and time

Path: **Settings ► General ► Date and time**

Parameter	Explanation
Date and time	Current date and time of the product <ul style="list-style-type: none"> ■ Settings: Year, Month, Day, Hour, Minute ■ Default setting: Current system time
Date format	Format in which the date is displayed Settings: <ul style="list-style-type: none"> ■ MM-DD-YYYY: month, day, year ■ DD-MM-YYYY: day, month, year ■ YYYY-MM-DD: year, month, day ■ Default setting: YYYY-MM-DD (e.g. "2016-01-31")

16.2.12 Units

Path: Settings ► General ► Units

Parameter	Explanation
Unit for linear values	Unit of measure for linear values <ul style="list-style-type: none"> ■ Settings: Millimeters or Inch ■ Default setting: Millimeters
Rounding method for linear values	Rounding method for linear values Settings: <ul style="list-style-type: none"> ■ Commercial: Decimal places from 1 to 4 are rounded down, decimal places from 5 to 9 are rounded up ■ Round off: Decimal places from 1 to 9 are rounded down ■ Round up: Decimal places from 1 to 9 are rounded up ■ Truncate: Decimal places are truncated without rounding up or down ■ Round to 0 and 5: Decimal places ≤ 24 or ≥ 75 are rounded to 0, decimal places ≥ 25 or ≤ 74 are rounded to 5 ■ Default setting: Commercial
Decimal places for linear values	Number of decimal places for linear values Setting range: <ul style="list-style-type: none"> ■ Millimeters: 0 ... 5 ■ Inch: 0 ... 7 Default value: <ul style="list-style-type: none"> ■ Millimeters: 4 ■ Inch: 6
Unit for angular values	Unit for angular values Settings: <ul style="list-style-type: none"> ■ Radian: angles in radian (rad) ■ Decimal degrees: angles in degrees (°) with decimal places ■ Deg-Min-Sec: angles in degrees (°), minutes ['] and seconds ["] ■ Default setting: Decimal degrees
Rounding method for angular values	Rounding method for decimal angular values Settings: <ul style="list-style-type: none"> ■ Commercial: Decimal places from 1 to 4 are rounded down, decimal places from 5 to 9 are rounded up ■ Round off: Decimal places from 1 to 9 are rounded down ■ Round up: Decimal places from 1 to 9 are rounded up ■ Truncate: Decimal places are truncated without rounding up or down ■ Round to 0 and 5: Decimal places ≤ 24 or ≥ 75 are rounded to 0, decimal places ≥ 25 or ≤ 74 are rounded to 5 ■ Default setting: Commercial

Parameter	Explanation
Decimal places for angular values	Number of decimal places for angular values Setting range: <ul style="list-style-type: none"> ■ Radian: 0 ... 7 ■ Decimal degrees: 0 ... 5 ■ Deg-Min-Sec: 0 ... 2 Default value: <ul style="list-style-type: none"> ■ Radian: 5 ■ Decimal degrees: 3 ■ Deg-Min-Sec: 0
Decimal separator	Separator for the display of values <ul style="list-style-type: none"> ■ Settings: Point or Comma ■ Default setting: Point

16.2.13 Copyrights

Path: **Settings ► General ► Copyrights**

Parameter	Meaning and function
Open source software	Display of the licenses of the software used

16.2.14 Service info

Path: **Settings ► General ► Service info**

Parameter	Meaning and function
HEIDENHAIN - Customer service	Display of a document containing HEIDENHAIN service addresses
OEM service info	Display of a document containing service information from the machine manufacturer <ul style="list-style-type: none"> ■ Default: document containing HEIDENHAIN service addresses Further information: "Adding documentation", Page 106

16.2.15 Documentation

Path: **Settings ► General ► Documentation**

Parameter	Meaning and function
Operating Instructions	Display of the operating instructions stored on the product <ul style="list-style-type: none"> ■ Default: no document; the document in the desired language can be added Further information: "Documentation", Page 269

16.3 Sensors

This chapter describes settings for configuring the sensors.



The following information applies only to the **Milling** application mode.

16.3.1 Touch probe

Path: **Settings ▶ Sensors ▶ Touch probe**

Parameters	Explanation
Touch probe	Selection of the edge finder Settings: <ul style="list-style-type: none"> ■ NONE ■ KT 130 Default value: NONE
Always use touch probe for probing	Definition whether the edge finder should always be used for probing <ul style="list-style-type: none"> ■ Setting range: ON or OFF ■ Default setting: OFF
Length	Length offset of the edge finder <ul style="list-style-type: none"> ■ Setting range: \geq 0.0001 ■ Default value: 0.0000
Diameter	Diameter of the edge finder <ul style="list-style-type: none"> ■ Setting range: \geq 0.0001 ■ Default value: 6.0000

16.4 Interfaces

This chapter describes settings for configuring networks, network drives, and USB mass storage devices.

16.4.1 Network

Path: **Settings ► Interfaces ► Network ► X116**



Contact your network administrator for the correct network settings for configuring the product.

Parameter	Explanation
MAC address	Unique hardware address of the network adapter
DHCP	Dynamically assigned network address of the product <ul style="list-style-type: none"> Settings: ON or OFF Default value: ON
IPv4 address	Network address consisting of four octets The network address is automatically assigned if DHCP is active, or it can be entered manually <ul style="list-style-type: none"> Setting range: 0.0.0.1 ... 255.255.255.255
IPv4 subnet mask	Identifier within the network, consisting of four octets The subnet mask is automatically assigned if DHCP is active, or it can be entered manually. <ul style="list-style-type: none"> Setting range: 0.0.0.0 ... 255.255.255.255
IPv4 standard gateway	Network address of the router connecting a network <div data-bbox="694 1350 751 1411" data-label="Image"> </div> <ul style="list-style-type: none"> The network address is automatically assigned if DHCP is active, or it can be entered manually. Setting range: 0.0.0.1 ... 255.255.255.255
IPv6 SLAAC	Network address with extended namespace Only required if supported in the network <ul style="list-style-type: none"> Settings: ON or OFF Default value: OFF
IPv6 address	Automatically assigned if IPv6 SLAAC is active
IPv6 subnet prefix length	Subnet prefix in IPv6 networks
IPv6 standard gateway	Network address of the router connecting a network
Preferred DNS server	Primary server for mapping the IP address
Alternative DNS server	Optional server for mapping the IP address

16.4.2 Network drive

Path: **Settings ► Interfaces ► Network drive**



Contact your network administrator for the correct network settings for configuring the product.

Parameter	Explanation
Name	Folder name displayed in the file management Default value: Share (cannot be changed)
Server IP address or host name	Name or network address of the server
Shared folder	Name of the shared folder
User name	Name of the authorized user
Password	Password of the authorized user
Show password	Display of the password in plain text <ul style="list-style-type: none"> Settings: ON or OFF Default value: OFF
Network drive options	Configuration of the Authentication for encrypting the password in the network Settings: <ul style="list-style-type: none"> None Kerberos V5 authentication Kerberos V5 authentication and packet signing NTLM password hashing NTLM password hashing with signing NTLMv2 password hashing NTLMv2 password hashing with signing Default value: None Configuration of the Mount options Settings: <ul style="list-style-type: none"> Default value: nounix,noserverino

16.4.3 USB

Path: **Settings ► Interfaces ► USB**

Parameter	Explanation
Automatically detect attached USB mass storage devices	Automatic recognition of a USB mass storage device <ul style="list-style-type: none"> Settings: ON or OFF Default setting: ON

16.4.4 Axes (switching functions)

Path: **Settings ► Interfaces ► Switching functions ► Axes**

Parameter	Explanation
General settings	Assignment of the digital input according to pin layout to zero reset all axes Default setting: Not connected
X	Assignment of the digital input according to pin layout to reset the axis to zero
Y	Default setting: Not connected
Z	
Zo	<div style="border: 1px solid black; padding: 5px;">  The availability of the axes depends on the configuration of the unit. </div>

16.4.5 Position-dependent switching functions

Path: **Settings ► Interfaces ► Position-dependent switching functions**

The position-dependent switching functions enable you to set logical outputs depending on the position of an axis in a defined reference system. Switching positions and position intervals are available for this.

Parameter	Explanation
Name	Name of the switching function
Switching function	Selecting whether the switching function should be activated or deactivated <ul style="list-style-type: none"> ■ Settings: ON or OFF ■ Default setting: ON
Reference system	Selecting the desired reference system <ul style="list-style-type: none"> ■ Machine coordinate system ■ Preset ■ Target position ■ Tool tip
Axis	Selecting the desired axis <ul style="list-style-type: none"> ■ X ■ Y ■ Z ■ Zo
Switching point	Selecting the axis position of the trigger point
Type of switching	Selecting the desired type of switching <ul style="list-style-type: none"> ■ Edge from LOW to HIGH ■ Edge from HIGH to LOW ■ Interval from LOW to HIGH ■ Interval from HIGH to LOW ■ Default setting: Edge from LOW to HIGH
Output	Selecting the desired output <ul style="list-style-type: none"> ■ X105.13 ... X105.16 (Dout 0, Dout 2, Dout 4, Dout 6) ■ X105.32 ... X105.35 (Dout 1, Dout 3, Dout 5, Dout 7) ■ X113.04 (Dout 0)
Pulse	Selecting whether the pulse should be activated or deactivated <ul style="list-style-type: none"> ■ Settings: ON or OFF ■ Default setting: ON
Pulse time	Selecting the desired pulse length <ul style="list-style-type: none"> ■ 0.1 s ... 999 s ■ Default setting: 0.0 s
Lower limit	Selecting the lower limit of the axis position at which switching is to occur (only with Interval type)
Upper limit	Selecting the upper limit of the axis position at which switching is to occur (only Interval type)
Remove the entry	Removing the position-dependent switching function

16.5 User

This chapter describes settings for configuring users and user groups.

16.5.1 OEM

Path: **Settings ► User ► OEM**

The **OEM** (Original Equipment Manufacturer) user has the highest level of permissions. This user is allowed to configure the product's hardware (e.g. connection of encoders and sensors). He can create **Setup** and **Operator**-type users, and configure the **Setup** and **Operator** users. The **OEM** user cannot be duplicated or deleted. This user cannot be logged in automatically.

Parameters	Explanation	Edit permission
Name	Name of the user ■ Default value: OEM	–
First name	First name of the user ■ Default value: –	–
Department	Department of the user ■ Default value: –	–
Group	Group of the user ■ Default value: oem	–
Password	Password of the user ■ Default value: oem	OEM
Language	Language of the user	OEM
Auto login	On restart of the product: Automatic login of the last logged-in user ■ Default value: OFF	–
Remove user account	Removal of the user account	–

16.5.2 Setup

Path: **Settings ► User ► Setup**

The **Setup** user configures the product for use at the place of operation. This user can create **Operator**-type users. The **Setup** user cannot be duplicated or deleted. This user cannot be logged in automatically.

Parameters	Explanation	Edit permission
Name	Name of the user ■ Default value: Setup	–
First name	First name of the user ■ Default value: –	–
Department	Department of the user ■ Default value: –	–
Group	Group of the user ■ Default value: setup	–
Password	Password of the user ■ Default value: setup	Setup, OEM
Language	Language of the user	Setup, OEM
Auto login	On restart of the product: Automatic login of the last logged-in user ■ Default value: OFF	–
Remove user account	Removal of the user account	–

16.5.3 Operator

Path: **Settings ► User ► Operator**

The **Operator** user is permitted to use the basic functions of the product. An **Operator**-type user cannot create additional users, but is allowed to edit various operator-specific settings, such as his name or the language. A user of the **Operator** group can be logged in automatically as soon as the product is switched on.

Parameters	Explanation	Edit permission
Name	Name of the user ■ Default value: operator	Operator, Setup, OEM
First name	First name of the user	Operator, Setup, OEM
Department	Department of the user ■ Default value: –	Operator, Setup, OEM
Group	Group of the user ■ Default value: operator	–
Password	Password of the user ■ Default value: operator	Operator, Setup, OEM
Language	Language of the user	Operator, Setup, OEM
Auto login	On restart of the product: Automatic login of the last logged-in user ■ Settings: ON or OFF ■ Default value: OFF	Operator, Setup, OEM
Remove user account	Removal of the user account	Setup, OEM

16.5.4 Adding a User

Path: **Settings ► User ► +**

Parameter	Explanation
	Adds a new user of the type Operator Further information: "Entering and configuring users", Page 124 It is not possible to add further OEM and Setup -type users.

16.6 Axes

This chapter describes settings for configuring the axes and assigned devices.

16.6.1 Reference marks

Path: **Settings ► Axes ► General settings ► Reference marks**

Parameters	Explanation
Reference mark search after unit start	Setting for the reference mark search after unit start Settings: <ul style="list-style-type: none"> ■ ON: The reference mark search must be performed after startup ■ OFF: No prompt for a mandatory reference mark search is displayed after startup of the product ■ Default value: ON
All users can cancel reference mark search	Specifies whether the reference mark search can be canceled by all user types Settings <ul style="list-style-type: none"> ■ ON: The reference mark search can be canceled by any user type ■ OFF: The reference mark search can only be canceled by OEM or Setup-user types ■ Default value: OFF
Reference mark search	Start starts the reference mark search and opens the workspace
Reference mark search status	Indicates whether the reference mark search was successful Display: <ul style="list-style-type: none"> ■ Successful ■ Unsuccessful
Stop of reference mark search	Indicates whether the reference mark search was canceled Display: <ul style="list-style-type: none"> ■ Yes ■ No

16.6.2 Information



The unit is available in variants equipped with differing features. The user interface elements and the unit's available functions that are shown here depend on the unit's features.

Path: **Settings ► Axes ► General settings ► Information**

Parameters	Explanation
Assignment of the encoder inputs to the axes	Shows the assignment of the encoder inputs to the axes
Assignment of the analog outputs to the axes	Shows the assignment of the analog outputs to the axes
Assignment of the analog inputs to the axes	Shows the assignment of the analog inputs to the axes
Assignment of the digital outputs to the axes	Shows the assignment of the digital outputs to the axes
Assignment of the digital inputs to the axes	Shows the assignment of the digital inputs to the axes



With the **Reset** buttons, the assignments for the inputs and outputs can be reset.

16.6.3 Switching functions

Path: **Settings ► Axes ► General settings ► Switching functions**



The switching functions must not be used as a part of a safety function.

Parameters	Explanation
Inputs	Assignment of the digital input for the respective switching function according to the pin layout Further information: "Inputs (Switching functions)", Page 246
Outputs	Assignment of the digital output for the respective switching function according to the pin layout Further information: "Outputs (Switching functions)", Page 246

16.6.4 Inputs (Switching functions)



The switching functions are available only for units with ID number 1089179-xx.



The switching functions must not be used as a part of a safety function.

Path: **Settings ▶ Axes ▶ General settings ▶ Switching functions ▶ Inputs**

Parameter	Explanation
Control voltage on	Assignment of the digital input for querying the external control voltage (e.g. for the machine to be controlled) <ul style="list-style-type: none"> Default value: Not connected
Emergency stop active	Assignment of the digital input for querying whether an external-ly connected emergency stop switch was activated <ul style="list-style-type: none"> Default value: Not connected

16.6.5 Outputs (Switching functions)



The switching functions are available only for units with ID number 1089179-xx.



The switching functions must not be used as a part of a safety function.

Path: **Settings ▶ Axes ▶ General settings ▶ Switching functions ▶ Outputs**

Parameter	Explanation
Coolant	Assignment of the digital output for activating or deactivating the coolant supply of the machine tool <ul style="list-style-type: none"> Default value: Not connected
Operational readiness	Assignment of the relay output set if an error (e.g. positioning error or standstill error) occurs on an axis. The error results in interruption of the axis control and power disconnection of the configured analog outputs of the axis. <ul style="list-style-type: none"> Default value: Not connected
User-defined switching function	Assignment of the relay output that activates for some seconds after shutdown of the product. The relay is connected to a circuit with self-retaining function that disconnects the product and machine tool from power if this signal is applied. The circuit can couple the switch-on/off of the product to the switch-on/off of the machine tool to be controlled. <ul style="list-style-type: none"> Default value: Not connected

16.6.6 Adding M functions

Path: Settings ► Axes ► General settings ► M functions ► +

Parameters	Explanation
Name	Entry of the name for the new M function <ul style="list-style-type: none"> Setting range: M100 ... M120 For the configuration, see "Configuring M functions", Page 247

16.6.7 Configuring M functions

Path: Settings ► Axes ► General settings ► M functions ► M100 ... M120

Parameters	Explanation
Name	Entry of the name for the M function <ul style="list-style-type: none"> Setting range: M100 ... M120
Digital output	Assignment of the digital output for the M function according to pin layout <ul style="list-style-type: none"> Default value: Not connected
Remove	Removal of the selected M function

16.6.8 Axes X, Y, Z, Zo

Path: Settings ► Axes ► X, Y, Z, Zo

Parameters	Explanation
Axis name	<p>In Milling application mode: Definition of the axis name is displayed in the position preview Settings:</p> <ul style="list-style-type: none"> ■ Not defined ■ X ■ Y ■ Z <p>Default setting: X, Y, Z</p> <hr/> <p>In Turning application mode: Definition of the axis name is displayed in the position preview Settings:</p> <ul style="list-style-type: none"> ■ Not defined ■ X ■ Z ■ Zo
Axis type	<p>Definition of the axis type Settings:</p> <ul style="list-style-type: none"> ■ Not defined ■ Linear axis ■ Spindle ■ Gear spindle <p>Default setting: Linear axis</p>
Encoder	<p>Configuration of the connected encoder Further information: "Encoder", Page 250</p>
Error compensation	<p>Configuration of the linear error compensation LEC or segmented linear error compensation SLEC Further information: "Linear error compensation (LEC)", Page 253 Further information: "Segmented linear error compensation (SLEC)", Page 253</p>
Positioning window	<p>Input of the scaling factor for the positioning aid in MDI mode</p> <ul style="list-style-type: none"> ■ Setting range: 0.020 mm ... 2.000 mm ■ Default value: 0.100

16.6.9 C axis

The auxiliary axis C designates the rotary axis that rotates about the Z axis and is used for angular measurement (e.g., for thread cutting). If the C axis is configured in the unit, then the position of the C axis can be read in the position display.

Path: **Settings ► Axes ► C**

Parameter	Explanation
Axis name	Definition of the axis name displayed in the position preview Settings: <ul style="list-style-type: none"> ■ Not defined ■ C Default setting: Not defined
Axis type	Definition of the axis type Settings: <ul style="list-style-type: none"> ■ Not defined ■ Linear axis Default setting: Linear axis
Encoder	Configuration of the connected encoder Further information: "Encoder", Page 250
Error compensation	Configuration of the linear error compensation LEC or segmented linear error compensation SLEC Further information: "Linear error compensation (LEC)", Page 253 Further information: "Segmented linear error compensation (SLEC)", Page 253
Positioning window	Input of the scaling factor for the positioning aid in MDI mode <ul style="list-style-type: none"> ■ Setting range: 0.020 mm ... 2.000 mm ■ Default value: 0.100

16.6.10 Encoder

Path: **Settings ► Axes ► X or Y or Z or Zo or C ► Encoder**

Encoder configuration for axis

Parameters	Explanation
Encoder input	Assignment of the encoder input to the axis of the product Settings: <ul style="list-style-type: none"> ■ Not connected ■ X1 (1 Vpp) ■ X2 (1 Vpp) ■ X3 (1 Vpp)
Incremental signal	Signal of the connected encoder Settings: <ul style="list-style-type: none"> ■ 1 Vpp: Sinusoidal voltage signal ■ 11 µApp: Sinusoidal current signal ■ Default value: 1 Vpp
Encoder model	Connected encoder model Settings: <ul style="list-style-type: none"> ■ Linear encoder: Linear axis ■ Angle encoder: Rotary axis ■ Angle encoder as linear encoder: Rotary axis is displayed as linear axis ■ Default value: Depending on the connected encoder
Signal period	For linear encoders: length of a signal period <ul style="list-style-type: none"> ■ Setting range: 0.001 µm ... 1000000.000 µm ■ Default value: 20.000
Line count	For angle encoders and display of a rotational axis as a linear axis: number of lines <ul style="list-style-type: none"> ■ Setting range: 1 ... 1000000 ■ Default value: 1000
Mechanical ratio	For display of a rotational axis as a linear axis: traverse path in mm per revolution <ul style="list-style-type: none"> ■ Setting range: 0.1 mm ... 1000 mm ■ Default value: 1.0
Reference marks	Configuration of the Reference marks Further information: "Reference marks (Encoder)", Page 252
Analog filter frequency	Frequency value of the analog low-pass filter (not with TTL) Settings: <ul style="list-style-type: none"> ■ 33 kHz: Suppression of interference frequencies above 33 kHz ■ 400 kHz: Suppression of interference frequencies above 400 kHz ■ Default value: 400 kHz

Parameters	Explanation
Terminating resistor	<p>Dummy load to avoid reflections</p> <ul style="list-style-type: none"> ■ Settings: ON or OFF ■ Default value: ON
Error monitor	<p>Monitoring of signal errors</p> <p>Settings:</p> <ul style="list-style-type: none"> ■ Off: Error monitoring not active ■ Amplitude: Error monitoring of signal amplitude ■ Frequency: Error monitoring of signal frequency ■ Frequency & amplitude: Error monitoring of signal amplitude and signal frequency ■ Default value: Frequency & amplitude <div style="border: 1px solid black; padding: 5px; margin-top: 10px;"> <p> A warning or error message is displayed if one of the limit values for error monitoring is exceeded.</p> </div> <p>The limit values depend on the signal of the connected encoder:</p> <ul style="list-style-type: none"> ■ Signal 1 Vpp, setting Amplitude <ul style="list-style-type: none"> ■ Warning with voltage ≤ 0.45 V ■ Error message with voltage ≤ 0.18 V or ≥ 1.34 V ■ Signal 1 Vpp, setting Frequency <ul style="list-style-type: none"> ■ Error message with frequency ≥ 400 kHz ■ Signal 11 μApp, setting Amplitude <ul style="list-style-type: none"> ■ Warning with current ≤ 5.76 μA ■ Error message with current ≤ 2.32 μA or ≥ 17.27 μA ■ Signal 11 μApp, setting Frequency <ul style="list-style-type: none"> ■ Error message with frequency ≥ 150 kHz
Counting direction	<p>Signal detection during axis movement</p> <p>Settings:</p> <ul style="list-style-type: none"> ■ Positive: The direction of traverse corresponds to the counting direction of the encoder ■ Negative: The direction of traverse does not correspond to the counting direction of the encoder ■ Default value: Positive

16.6.11 Reference marks (Encoder)

Path: **Settings ▶ Axes ▶ X or Y or Z or Zo or C ▶ Encoder ▶ Reference marks**



The following parameters depend on the type of encoder connected and the setting of the reference marks.

Further information: "Encoder", Page 250

Parameters	Explanation
Reference mark	Definition of the type of reference mark Settings: <ul style="list-style-type: none"> ■ None: There is no reference mark ■ One: The encoder has one reference mark ■ Coded: The encoder has distance-coded reference marks ■ Default value: One
Maximum traverse path	For linear encoders with coded reference marks: maximum traverse path for determining the absolute position <ul style="list-style-type: none"> ■ Setting range: 0.1 mm ... 10000.0 mm ■ Default value: 20.0
Nominal increment	For angle encoders with coded reference marks: maximum nominal increment for determining the absolute position <ul style="list-style-type: none"> ■ Setting range: > 0° ... 360° ■ Default value: 10.0
Reference point displacement	Configuration of the offset between the reference mark and the zero point Further information: "Reference point displacement", Page 252

16.6.12 Reference point displacement

Path: **Settings ▶ Axes ▶ X or Y or Z or Zo or C ▶ Encoder ▶ Reference marks ▶ Reference point displacement**

Parameters	Explanation
Reference point displacement	Activation of offset calculation between reference mark and datum of the machine <ul style="list-style-type: none"> ■ Setting range: ON or OFF ■ Default value: OFF
Reference point displacement	Manual input of the offset (in mm or degrees according to the selected encoder type) between reference mark and datum Default value: 0.00000
Current position for reference point shift	Apply applies the current position as offset (in mm or degrees, depending on the selected encoder model) between reference marks and zero point

16.6.13 Linear error compensation (LEC)

Path: **Settings ▶ Axes ▶ X or Y or Z or Zo or C ▶ Error compensation ▶ Linear error compensation (LEC)**

Parameter	Explanation
Compensation	<p>Mechanical influences on the axes of the machine are compensated</p> <p>Settings:</p> <ul style="list-style-type: none"> ■ ON: Compensation is active ■ OFF: Compensation is not active ■ Default value: OFF <div style="border: 1px solid black; padding: 5px; margin-top: 10px;"> <p> If Compensation is active, the Nominal length and Actual length cannot be edited or generated.</p> </div>
Nominal length	Input field for Nominal length in mm
Actual length	Input field for Actual length in mm

16.6.14 Segmented linear error compensation (SLEC)

Path: **Settings ▶ Axes ▶ X or Y or Z or Zo or C ▶ Error compensation ▶ Segmented linear error compensation (SLEC)**

Parameters	Explanation
Compensation	<p>Mechanical influences on the axes of the machine are compensated</p> <p>Settings:</p> <ul style="list-style-type: none"> ■ ON: Compensation is active ■ OFF: Compensation is not active ■ Default value: OFF <div style="border: 1px solid black; padding: 5px; margin-top: 10px;"> <p> When Compensation is active, then the Table of supporting points cannot be edited or created.</p> </div>
Table of supporting points	Opens the table of supporting points for manual editing
Create table of supporting points	<p>The menu for creating a new Table of supporting points is opened</p> <p>Further information: "Create table of supporting points", Page 254</p>

16.6.15 Create table of supporting points

Path: **Settings ► Axes ► X or Y or Z or Zo or C ► Error compensation ► Segmented linear error compensation (SLEC) ► Create table of supporting points**

Parameters	Explanation
Number of supporting points	Number of supporting points on the mechanical axis of the machine <ul style="list-style-type: none"> ■ Setting range: 2 ... 200 ■ Default value: 2
Spacing of the supporting points	Spacing of the supporting points on the mechanical axis of the machine <ul style="list-style-type: none"> ■ Default value: 100.00000
Start point	The start point defines the position starting from which the compensation is applied to the axis <ul style="list-style-type: none"> ■ Default value: 0.00000
Create	Creates a new table of supporting points based on the entries

16.6.16 Spindle axis S



The switching functions are available only for units with ID number 1089179-xx.

Path: **Settings ► Axes ► Spindle axis S**

Parameters	Explanation
Axis name	Definition of the axis name displayed in the position preview Settings: <ul style="list-style-type: none"> ■ Not defined ■ S Default setting: S
Axis type	Definition of the axis type Settings: <ul style="list-style-type: none"> ■ Not defined ■ Linear axis ■ Spindle ■ Gear spindle Default setting: Spindle
Outputs	Configuration of the Outputs for the spindle Further information: "Outputs (S)", Page 256
Inputs	Configuration of the Inputs for the spindle Further information: "Inputs (S)", Page 256
Gear stages	Configuration of the Gear stages for the Gear spindle Further information: "Configuring Gear stages", Page 258

Parameters	Explanation
Gear stage selection through an external signal	<p>Selection of the Gear stages of the Gear spindle via external signals</p> <p>Settings</p> <ul style="list-style-type: none"> ■ ON: Selection of the Gear stages is performed via external signals ■ OFF: Selection of the Gear stages is performed manually in the operating modes ■ Default value: OFF
Start-up time for upper spindle speed range	<p>Definition of the required Start-up time until Smax is reached</p> <ul style="list-style-type: none"> ■ Setting range: 50 ms ... 10000 ms ■ Default value: 500
Start-up time for lower spindle speed range	<p>Definition of the required Start-up time until Smax is reached</p> <ul style="list-style-type: none"> ■ Setting range: 50 ms ... 10000 ms ■ Default value: 500
Break point of characteristic curve for start-up times	<p>Setting of the spindle speed that marks the transition from the upper to the lower spindle speed range</p> <ul style="list-style-type: none"> ■ Setting range: 0 rpm ... 2000 rpm ■ Default value: 1500
Minimum spindle speed	<p>Definition of the minimum spindle speed</p> <ul style="list-style-type: none"> ■ Setting range: 0 rpm ... 500 rpm ■ Default value: 50
Maximum spindle speed for oriented spindle stop	<p>Definition of the maximum spindle speed for oriented spindle stop</p> <ul style="list-style-type: none"> ■ Setting range: 0 rpm ... 500 rpm ■ Default value: 30
Maximum spindle speed for thread cutting	<p>Definition of the maximum spindle speed for thread cutting</p> <ul style="list-style-type: none"> ■ Setting range: 100 rpm ... 2000 rpm ■ Default value: 1000

16.6.17 Outputs (S)



The switching functions are available only for units with ID number 1089179-xx.

Path: **Settings ▶ Axes ▶ S ▶ Outputs**

Parameters	Explanation
Analog output	Assignment of the analog output according to pin layout <ul style="list-style-type: none"> ■ Default value: Not connected
Analog output is inverted	If this function is active, the analog signal is inverted at the output <ul style="list-style-type: none"> ■ Default value: not active
Smax	Definition of the Spindle speed attained with Umax <ul style="list-style-type: none"> ■ Setting range: 100 rpm ... 10000 rpm ■ Default value: 2000
Umax	Maximum voltage that is output at the analog output in order to attain Smax <ul style="list-style-type: none"> ■ Setting range: 1000 mV ... 10000 mV ■ Default value: 9000
Enable spindle CW	Assignment of the digital output for the clockwise spindle enable according to pin layout <ul style="list-style-type: none"> ■ Default value: Not connected
Enable spindle CCW	Assignment of the digital output for the counterclockwise spindle enable according to pin layout <ul style="list-style-type: none"> ■ Default value: Not connected



16.6.18 Inputs (S)



The switching functions are available only for units with ID number 1089179-xx.

Path: **Settings ▶ Axes ▶ S ▶ Inputs**

Parameters	Explanation
Enable digital movement commands	Use of the digital movement commands <ul style="list-style-type: none"> ■ Settings: ON or OFF ■ Default value: OFF
Spindle start	Assignment of the digital input for the spindle start according to pin layout <ul style="list-style-type: none"> ■ Default value: Not connected
Spindle stop	Assignment of the digital input for the spindle stop according to pin layout <ul style="list-style-type: none"> ■ Default value: Not connected
Digital enable inputs	Configuration of the digital inputs for the spindle enable

Parameters	Explanation
Spindle ready	Assignment of a digital input; indicates that the spindle is in reliable condition <ul style="list-style-type: none"> Default value: Not connected
Spindle interrupt	Assignment of a digital input; in active state it immediately disconnects from power the configured analog output of the spindle. A spindle movement is stopped without a ramp, axes with automatic traverse are stopped if applicable and spindle activation is prevented. <div style="border: 1px solid black; padding: 5px; margin-top: 10px;">  The machine tool builder is responsible for the immediate stopping of the spindles. </div> <ul style="list-style-type: none"> Default value: Not connected
Spindle protection device	Assignment of a digital input; indicates whether an existing spindle protection device is open or closed. This signal influences error messages and program run. <div style="border: 1px solid black; padding: 5px; margin-top: 10px;">  The machine tool builder is responsible for the immediate shutdown of the spindles with opened spindle protection. </div> <ul style="list-style-type: none"> Default value: Not connected
Spindle sleeve final position +	Assignment of a digital input for the upper limit switch of the sleeves. The input is used for reversing the spindle with thread cutting. <ul style="list-style-type: none"> Default value: Not connected
Spindle sleeve final position -	Assignment of a digital input for the lower limit switch of the sleeves. The input is used for reversing the spindle with thread cutting. <ul style="list-style-type: none"> Default value: Not connected
Spindle position	Assignment of a digital input; the signal positions the spindle at low speed during stopping to a desired position <ul style="list-style-type: none"> Default value: Not connected

16.6.19 Adding Gear stages

Path: **Settings ▶ Axes ▶ S ▶ Gear stages ▶ +**

Parameter	Explanation
	Adding a new gear stage with default name Further information: "Configuring Gear stages", Page 258

16.6.20 Configuring Gear stages

Path: Settings ► Axes ► S ► Gear stages

Parameter	Explanation
Name	Entry of the name for the gear stage <ul style="list-style-type: none"> Default value: Stage [n]
Gear stage is active	Assignment of the digital input for selection of the gear stage via an external signal <ul style="list-style-type: none"> Default value: Not connected
Smax	Definition of the Spindle speed attained with Umax <ul style="list-style-type: none"> Setting range: 100 rpm ... 10 000 rpm Default value: 2000
Start-up time for upper spindle speed range	Definition of the required Start-up time until Smax is reached <ul style="list-style-type: none"> Setting range: 50 ms ... 10 000 ms Default value: 500
Start-up time for lower spindle speed range	Definition of the required Start-up time until Smax is reached <ul style="list-style-type: none"> Setting range: 50 ms ... 10 000 ms Default value: 500
Break point of characteristic curve for start-up times	Setting of the spindle speed that marks the transition from the upper to the lower spindle speed range <ul style="list-style-type: none"> Setting range: 0 rpm ... 2000 rpm Default value: 1500
Minimum spindle speed	Definition of the minimum spindle speed <ul style="list-style-type: none"> Setting range: 0 rpm ... 500 rpm Default value: 50
Remove	Removal of the selected gear stage

16.7 Service

This chapter describes settings for product configuration, for maintaining the firmware and for enabling software options.

16.7.1 Firmware information

Path: **Settings ► Service ► Firmware information**

The following information on the individual software modules is displayed for service and maintenance.

Parameter	Explanation
Core version	Version number of the microkernel
Microblaze bootloader version	Version number of the Microblaze bootloader
Microblaze firmware version	Version number of the Microblaze firmware
Extension PCB bootloader version	Version number of the bootloader (expansion board)
Extension PCB firmware version	Version number of the firmware (expansion board)
Boot ID	ID number of the boot process
HW Revision	Revision number of the hardware
C Library Version	Version number of the C library
Compiler Version	Version number of the compiler
Touchscreen Controller version	Version number of the touchscreen controller
Number of unit starts	Number of times the product was switched on
Qt build system	Version number of the Qt compilation software
Qt runtime libraries	Version number of the Qt runtime libraries
Kernel	Version number of the Linux kernel
Login status	Information on the logged-in user
SystemInterface	Version number of the system interface module
BackendInterface	Version number of the backend interface module
GuiInterface	Version number of the user interface module
TextDataBank	Version number of the text database module
Optical edge detection	Version number of the optical edge detection module
NetworkInterface	Version number of the network interface module
OSInterface	Version number of the operating system interface module
PrinterInterface	Version number of the printer interface module
system.xml	Version number of the system parameters
axes.xml	Version number of the axis parameters
encoders.xml	Version number of the encoder parameters
ncParam.xml	Version number of the NC parameters
spindle.xml	Version number of the spindle axis parameters
io.xml	Version number of the parameters for inputs and outputs

Parameter	Explanation
mFunctions.xml	Version number of the M function parameters
peripherals.xml	Version number of the parameters for peripherals
slec.xml	Version number of the parameters for segmented linear error compensation (SLEC)
lec.xml	Version number of the parameters for linear error compensation (LEC)
microBlazePVRegister.xml	Version number of the "Processor Version Register" of MicroBlaze
info.xml	Version number of the information parameters
audio.xml	Version number of the audio parameters
network.xml	Version number of the network parameters
os.xml	Version number of the operating system parameters
runtime.xml	Version number of the runtime parameters
serialPort.xml	Version number of the parameters of the serial interface
users.xml	Version number of the user parameters
GI Patch Level	Patch level of the golden image (GI)

16.7.2 Back up and restore

Path: **Settings ► Service ► Back up and restore**

The unit's settings or user files can be backed up as a file so that they are available after a reset to the factory default settings has been performed or for installation on multiple units.

Parameters	Explanation
Restore settings	Restoring of the backed up settings Further information: "Restore settings", Page 276
Back up settings	Backing up of settings of the product Further information: "Back up settings", Page 117
Back up user files	Backing up of user files of the product Further information: "Back up user files", Page 118

16.7.3 Firmware update

Path: **Settings ► Service ► Firmware update**

The firmware is the operating system of the product. You can import new versions of the firmware via the product's USB port or the network connection.



Prior to the firmware update, you must comply with the release notes for the respective software version and the information they contain regarding reverse compatibility.



In order to be on the safe side, the current settings must be backed up if the unit's firmware is going to be updated.

Further information: "Updating the firmware", Page 274

16.7.4 Reset

Path: **Settings ► Service ► Reset**

If necessary, you can reset the unit's settings to the factory default settings or to the condition at delivery. Software options are deactivated and subsequently need to be reactivated with the available license key.

Parameter	Explanation
Reset all settings	The settings are reset to factory default settings Further information: "Reset all settings", Page 277
Reset to shipping conditions	Resetting of the settings to the factory default setting and deletion of the user files from the unit's memory area Further information: "Reset to shipping conditions", Page 277

16.7.5 OEM area

Path: **Settings ► Service ► OEM area**

Parameters	Explanation
Documentation	Addition of OEM documentation, e.g. service information Further information: "Adding documentation", Page 106
Startup screen	Changing the startup screen (e.g., with one's own company logo) Further information: "Adding a startup screen", Page 107
OEM bar	Customization of the OEM bar with specific functions Further information: "OEM bar", Page 262
Settings	Changing the user mode, override display, and the keyboard design Further information: "Settings (OEM area)", Page 267
Remote access for screenshots	Permitting a network connection with the ScreenshotClient program so that ScreenshotClient can take screenshots of the unit from a computer Settings: <ul style="list-style-type: none"> ■ ON: Remote access is possible ■ OFF: Remote access is not possible ■ Default value: OFF



When the unit is shut down, **Remote access for screenshots** is automatically deactivated.

16.7.6 OEM bar

Path: **Settings ► Service ► OEM area ► OEM bar**

Parameters	Explanation
Show bar	Display of the OEM bar Settings: <ul style="list-style-type: none"> ■ ON: The OEM bar is displayed on the user interface of the respective operating modes ■ OFF: The OEM bar is not displayed Default value: OFF
Bar items	Configuration of the Bar items on the OEM bar Further information: "Adding OEM-Bar items", Page 263

16.7.7 Adding OEM-Bar items

Path: Settings ► Service ► OEM area ► OEM bar ► Bar items ► +

Parameters	Explanation
Description	Description of the bar item on the OEM bar
Type	<p>Selecting the new bar item on the OEM bar</p> <p>Settings:</p> <ul style="list-style-type: none"> ■ Empty ■ Logo ■ Spindle speed ■ M function ■ Special functions ■ Document <p>Default value: Empty</p>
Parameters	<p>The available parameters depend on the type of bar item selected:</p> <ul style="list-style-type: none"> ■ Logo: Further information: "Logo OEM bar item", Page 264 ■ Spindle speed: Further information: "Spindle speed OEM bar item", Page 264 ■ M functions: Further information: "M function OEM bar item", Page 265 ■ Special functions: Further information: "Special functions OEM bar item", Page 266 ■ Document: Further information: "Document OEM bar item", Page 267
Remove bar entry	Removing the bar item from the OEM bar

16.7.8 Logo OEM bar item

Path: **Settings ► Service ► OEM area ► OEM bar ► Bar items ► Logo**

Parameters	Explanation
Description	Description of the bar item on the OEM bar
Type	Logo
Select logo	Selecting the desired image for the depiction
Link to documentation	Using a logo for calling linked documentation Settings: <ul style="list-style-type: none"> ■ None ■ Operating Instructions ■ OEM service info Default value: None
Upload image file	Copies a selected image file to the storage location /Oem/Images <ul style="list-style-type: none"> ■ File format: PNG, JPG, PPM, BMP or SVG ■ Image size: max. 140 x 70 px
Remove bar entry	Removing the bar item from the OEM bar

16.7.9 Spindle speed OEM bar item

Path: **Settings ► Service ► OEM area ► OEM bar ► Bar items ► Spindle speed**

Parameters	Explanation
Description	Description of the bar item on the OEM bar
Type	Spindle speed
Spindle	S
Spindle speed	Setting the spindle speed <ul style="list-style-type: none"> ■ Setting range: depends on the configuration of the spindle axis S ■ Default value: 0
Remove bar entry	Removing the bar item from the OEM bar

16.7.10 M function OEM bar item

Path: Settings ► Service ► OEM area ► OEM bar ► Bar items ► M function

Parameters	Explanation
Description	Description of the bar item on the OEM bar
Type	M function
Number of the M function	<p>Selection of the desired M function</p> <p>Setting ranges</p> <ul style="list-style-type: none"> ■ 100.T ... 120.T (TOGGLE: switches between the states when tapped) ■ 100.P ... 120.P (PULSE: The length can be set in Pulse time) ■ Default value: Empty
Pulse time	<p>Selecting the length of the high-active pulse</p> <p>Setting range</p> <ul style="list-style-type: none"> ■ 8 ms ... 1500 ms ■ Default value: 500 ms
Restart	<p>Restarting the pulse duration</p> <ul style="list-style-type: none"> ■ Settings: ON or OFF ■ Default value: OFF
Select image for active function	Selecting the desired image for depicting the active function
Select image for inactive function	Selecting the desired image for depicting the inactive function
Upload image file	<p>Copies a selected image file to the storage location /Oem/Images</p> <ul style="list-style-type: none"> ■ File format: PNG, JPG, PPM, BMP or SVG ■ Image size: Max. 100 x 70 px
Remove bar entry	Removing the bar item from the OEM bar

16.7.11 Special functions OEM bar item

Path: Settings ► Service ► OEM area ► OEM bar ► Bar items ► Special functions

Parameters	Explanation
Description	Description of the bar item on the OEM bar
Type	Special functions
Function	<p>Selection of the desired special function</p> <p>Settings:</p> <ul style="list-style-type: none"> ■ Thread cutting ■ Spindle direction ■ Coolant ■ Coolant during spindle operation ■ Clamp axes: this function is not supported by units of this series ■ Zero tool axis <p>Default value: Thread cutting</p>
Spindle	<p>Only with Spindle direction function:</p> <p>S</p>
Select image for clockwise spindle direction	<p>Only with Spindle direction function:</p> <p>Selecting the desired image for clockwise spindle rotation</p>
Select image for counterclockwise spindle direction	<p>Only with Spindle direction function:</p> <p>Selecting the desired image for counterclockwise spindle rotation</p>
Select image for active function	Selecting the desired image for depicting the active function
Select image for inactive function	Selecting the desired image for depicting the inactive function
Upload image file	<p>Copies a selected image file to the storage location /Oem/Images</p> <ul style="list-style-type: none"> ■ File format: PNG, JPG, PPM, BMP or SVG ■ Image size: Max. 100 x 70 px
Remove bar entry	Removing the bar item from the OEM bar

16.7.12 Document OEM bar item

Path: Settings ► Service ► OEM area ► OEM bar ► Bar items ► Document

Parameters	Explanation
Description	Description of the bar item on the OEM bar
Type	Document
Select a document	Selecting the desired document
Select image for display	Selecting the desired image for depicting the function
Upload image file	Copies a selected image file to the storage location /Oem/Images
Remove bar entry	Removing the bar item from the OEM bar

16.7.13 Settings (OEM area)

Path: Settings ► Service ► OEM area ► Settings

Parameters	Explanation
Application	The type of application mode; a change does not become active until a restart is performed Settings: <ul style="list-style-type: none"> ■ Milling ■ Turning Default value: Milling
Override display	 The current firmware of the units in this series does not support this function.
Keyboard theme	Selection of the keyboard layout Settings: <ul style="list-style-type: none"> ■ Standard: entry confirmed with (Return) ■ TNC: entry confirmed with (Enter) Default value: Standard
Program run	Modifying of the program execution Further information: "Program execution", Page 267

16.7.14 Program execution

Path: Settings ► Service ► OEM area ► Settings ► Program run

Parameter	Explanation
Automatic advance on reaching upper spindle sleeve final position	Automatic advance when executing hole patterns always occurs when the upper spindle sleeve limit switch is reached <ul style="list-style-type: none"> ■ Settings: ON or OFF ■ Default value: OFF
M functions	For the configuration, see "Configuring M functions", Page 269

16.7.15 Text database

Path: **Settings ► Service ► OEM area ► Settings ► Text database**

The device features the option of importing an individual text database. The Messages option allows you to show various messages.

Parameter	Explanation
Select text database	Selecting an XML type text database stored in the device
Deselect text database	Deselecting the currently selected text database

16.7.16 Messages

Path: **Settings ► Service ► OEM area ► Settings ► Messages**

The device features the option of showing messages. For this purpose you can select the texts from your text database or directly enter a text.

Parameter	Explanation
Name	Description of the message
Text ID or text	Selecting the message to be displayed Settings: <ul style="list-style-type: none"> ■ Enter the desired text ID from the file selected in the text database Further information: "Text database", Page 268 ■ Enter the error message to be displayed
Message type	Selecting the desired type of message Settings: <ul style="list-style-type: none"> ■ Standard: If the input is no longer active, the message is no longer displayed ■ Acknowledgment by user: The user has to acknowledge the message to make it disappear ■ Default value: Standard
Input	Selecting the desired input Setting range <ul style="list-style-type: none"> ■ X105.1 ... X105.12 (Din 1 ... Din 12) ■ X105.20 ... X105.31 (Din 20 ... Din 23) ■ X113.07, X113.09, X113.10, X113.14 (Din 0 ... Din 3)
Remove the entry	Removing the message entry

16.7.17 Configuring M functions

Path: **Settings ► Service ► OEM area ► Settings ► Program run ► M functions**

Parameter	Explanation
Number of the M function	Enter the number of the new M function <ul style="list-style-type: none"> ■ Setting range: M2.0 ... M120.0 (0): The output assigned to the M function is switched to inactive) ■ Setting range: M2.1 ... M120.1 (1): The output assigned to the M function is switched to active) ■ Setting range: M2.2 ... M120.2 (2): The output assigned to the M function generates a high active pulse of 8 ms)
Select image for dialog during program run	Select the desired image for display during program run
Upload image file	Copies a selected image file to the storage location /Oem/Images <ul style="list-style-type: none"> ■ File format: PNG, JPG, PPM, BMP or SVG ■ Image size: Max. 100 x 70 px
Remove the entry	Remove the entry

16.7.18 Documentation

Path: **Settings ► Service ► Documentation**

The product provides the possibility to upload the corresponding Operating Instructions in the desired language. The Operating Instructions can be copied from the supplied USB mass storage device to the product.

The latest version can be downloaded from the download area at www.heidenhain.de.

Parameters	Explanation
Add Operating Instructions	Adding the Operating Instructions in the desired language

16.7.19 Software options

Path: **Settings ► Service ► Software options**



The current firmware of the units in this series does not support this function.

16.7.20 Back up and restore (OEM configuration)

Path: **Settings ► Service ► OEM area ► Back up and restore**

Parameter	Explanation
Back up OEM specific folders and files	The configuration of the OEM area is saved as a ZIP file
Restore OEM specific folders and files	The configuration of the OEM area can be decompressed and restored from the ZIP file

17

**Service and
Maintenance**

17.1 Overview

This chapter describes the general maintenance work on the product.



The following steps must be performed only by qualified personnel.

Further information: "Personnel qualification", Page 27



This chapter contains a description of maintenance work for the product only. Any maintenance work on peripheral devices is not described in this chapter.

Further information: Manufacturer's documentation for the respective peripheral devices

17.2 Cleaning

NOTICE

Cleaning with sharp-edged objects or aggressive cleaning agents

Improper cleaning will cause damage to the product.

- ▶ Never use abrasive or aggressive cleaners, and never use strong detergents or solvents
- ▶ Do not use sharp-edged objects to remove persistent contamination

Cleaning the housing

- ▶ Use only a cloth dampened with water and a mild detergent for cleaning the exterior surfaces

Cleaning the screen

Activate cleaning mode to clean the display. This switches the unit to an inactive state without interrupting the power supply. The screen is switched off in this state.



- ▶ Tap **Switch-off** in the main menu to activate the cleaning mode



- ▶ Tap **Cleaning mode**
- > The screen switches off
- ▶ Use a lint-free cloth and a commercially available glass cleaner to clean the screen



- ▶ To deactivate the cleaning mode, tap anywhere on the touchscreen
- > An arrow appears at the bottom of the screen
- ▶ Drag the arrow up
- > The screen is switched on and shows the user interface last displayed

17.3 Maintenance plan

The product is largely maintenance-free.

NOTICE

Operating defective products

Operating defective products may result in serious consequential damage.

- ▶ Do not repair or operate the device if it is damaged
- ▶ Replace defective products immediately or contact a HEIDENHAIN service agency



The following steps are only to be performed by electrical specialists.

Further information: "Personnel qualification", Page 27

Maintenance step	Interval	Corrective action
▶ All labels and symbols provided on the product must be checked for readability	Annually	▶ Contact HEIDENHAIN service agency
▶ Inspect electrical connections for damage and check their function	Annually	▶ Replace defective cables. Contact HEIDENHAIN service agency if required
▶ Check power cables for faulty insulation and weak points	Annually	▶ Replace power cables according to the specification

17.4 Resuming operation

When operation is resumed, e.g. when the product is reinstalled after repair or when it is remounted, the same measures and personnel requirements apply as for mounting and installing the product.

Further information: "Mounting", Page 35

Further information: "Installation", Page 41

When connecting the peripheral devices (e.g. encoders), the operating company must ensure safe resumption of operation and assign authorized and appropriately qualified personnel to the task.

Further information: "Obligations of the operating company", Page 28

17.5 Updating the firmware

The firmware is the operating system of the product. You can import new versions of the firmware via the product's USB port or the network connection.



Prior to the firmware update, you must comply with the release notes for the respective software version and the information they contain regarding reverse compatibility.



In order to be on the safe side, the current settings must be backed up if the unit's firmware is going to be updated.

Requirement

- The new firmware is available as a *.dro file
- To update the firmware over the USB port, the current firmware must be stored on a USB mass storage device (FAT32 format)
- To update the firmware via the network interface, the current firmware must be available in a folder on the network drive

Starting a firmware update



- ▶ Tap **Settings** in the main menu
- ▶ Tap **Service**
- ▶ Open in the sequence
 - **Firmware update**
 - **Continue**
- > The service application is launched

Updating the firmware

The firmware can be updated from a USB mass storage device (FAT32 format) or via a network drive.



- ▶ Tap **Firmware update**
- ▶ Tap **Select**
- ▶ If required, connect a USB mass storage device to a USB port of the product
- ▶ Navigate to the folder containing the new firmware



If you have accidentally tapped the wrong folder, you can return to the previous folder.

- ▶ Tap the file name that is displayed above the list

- ▶ Select the firmware
- ▶ Tap **Select** to confirm the selection
- ▶ The firmware version information is displayed
- ▶ Tap **OK** to close the dialog



The firmware update cannot be canceled once the data transfer has started.

- ▶ Tap **Start** to start the update
- ▶ The screen shows the progress of the update
- ▶ Tap **OK** to confirm successful update
- ▶ Tap **Finish** to terminate the service application
- ▶ The service application is terminated
- ▶ The main application is launched
- ▶ If automatic user login is active, the user interface is displayed in the **Manual operation** menu
- ▶ If automatic user login is not active, the **User login** menu is displayed

Safely removing a USB mass storage device



- ▶ Tap **File management** in the main menu
- ▶ Navigate to the list of storage locations



- ▶ Tap **Safely remove**
- ▶ The message **The storage medium can be removed now.** appears
- ▶ Disconnect the USB mass storage device

17.6 Restore settings

Backed-up settings can be restored to the product. The current configuration of the product is replaced in the process.



Software options that were active when the settings were backed up must be activated before restoring the settings.

A restore can be necessary in the following cases:

- During commissioning, the settings are set on a product and transferred to all identical products
Further information: "Steps for commissioning", Page 94
- After a reset, the settings are copied back to the product
Further information: "Reset all settings", Page 277



- ▶ Tap **Settings** in the main menu
- ▶ Open in the sequence
 - **Service**
 - **Back up and restore**
 - **Restore settings**
- ▶ Tap **Complete restoration**
- ▶ If required, connect a USB mass storage device (FAT32 format) to a USB port of the product
- ▶ Navigate to the folder containing the backup file
- ▶ Select the backup file
- ▶ Tap **Select**
- ▶ Confirm successful transfer with **OK**
- > The system is shut down
- ▶ To restart the product with the transferred configuration data, switch the product off and then back on

Safely removing a USB mass storage device



- ▶ Tap **File management** in the main menu
- ▶ Navigate to the list of storage locations
- ▶ Tap **Safely remove**
- > The message **The storage medium can be removed now.** appears
- ▶ Disconnect the USB mass storage device



17.7 Reset all settings

You can reset the settings of the product to the factory defaults if required. The software options are deactivated and subsequently need to be reactivated with the available license key.



- ▶ Tap **Settings** in the main menu
- ▶ Tap **Service**
- ▶ Open in the sequence
 - **Reset**
 - **Reset all settings**
- ▶ Enter password
- ▶ Confirm the entry with **RET**
- ▶ To show the password in plain text, activate **Show password**
- ▶ Tap **OK** to confirm the action
- ▶ Tap **OK** to confirm the reset
- ▶ Tap **OK** to confirm shutdown of the product
- > The product is shut down
- > All settings are reset
- > To restart the product, switch it off and then back on

17.8 Reset to shipping conditions

You can reset the settings of the product to the factory defaults and delete the user files from its memory range. The software options are deactivated and subsequently need to be reactivated with the available license key.



- ▶ Tap **Settings** in the main menu
- ▶ Tap **Service**
- ▶ Open in the sequence
 - **Reset**
 - **Reset to shipping conditions**
- ▶ Enter password
- ▶ Confirm the entry with **RET**
- ▶ To show the password in plain text, activate **Show password**
- ▶ Tap **OK** to confirm the action
- ▶ Tap **OK** to confirm the reset
- ▶ Tap **OK** to confirm shutdown of the product
- > The product is shut down
- > All settings are reset and the user files are deleted
- > To restart the product, switch it off and then back on

18

What to do if ...

18.1 Overview

This chapter describes the causes of faults or malfunctions of the product and the appropriate corrective actions.



Make sure that you have read and understood the "Basic Operation" chapter before carrying out the actions described below.

Further information: "Basic Operation", Page 57

18.2 System or power failure

Operating system data can be corrupted in the following cases:

- System or power failure
- Switching off the product without shutting down the operating system

If the firmware is damaged, the product starts a Recovery System that displays short instructions on the screen.

With restoration, the Recovery System overwrites the damaged firmware with a new firmware previously saved to a USB mass storage device. During this procedure the settings of the product are deleted.

18.2.1 Restoring the firmware

- ▶ On a computer, create the folder "heidenhain" on a USB mass storage device (FAT32 format).
- ▶ In the "heidenhain" folder, create the folder "update"
- ▶ Copy the new firmware to the "update" folder
- ▶ Rename the firmware "recovery.dro"
- ▶ Switch off the product
- ▶ Connect a USB mass storage device to a USB port of the product
- ▶ Switch on the product
- > The product starts the Recovery System
- > The USB mass storage device is detected automatically
- > The firmware is installed automatically
- > After a successful update, the firmware is automatically renamed "recovery.dro.[yyyy.mm.dd.hh.mm]"
- ▶ Restart the product on completion of the installation
- > The product starts up with the factory defaults

18.2.2 Restore settings

Reinstalling the firmware resets the product to the factory defaults. This deletes the setting, including the error compensation values . Not affected by this are user files saved in the memory or files that are retained after a firmware reinstallation.

To restore settings, you must either reconfigure them on the unit yourself or restore previously backed up settings on the unit.

- ▶ Restoring settings

Further information: "Restore settings", Page 276

18.3 Malfunctions

If faults or malfunctions that are not listed in the "Troubleshooting" table below occur during operation, refer to the machine tool builder's documentation or contact a HEIDENHAIN service agency.

18.3.1 Troubleshooting



The following troubleshooting steps must be performed only by the personnel indicated in the table.

Further information: "Personnel qualification", Page 27

Fault	Cause of fault	Correction of fault	Personnel
The status LED remains dark after switch-on	There is no supply voltage	▶ Check the power cable	Electrical specialist
	The product does not function properly	▶ Contact a HEIDENHAIN service agency	Qualified personnel
A blue screen appears when the unit starts up	Firmware error during startup	▶ If this fault occurs for the first time, switch the product off and then on again ▶ If the fault recurs, contact a HEIDENHAIN service agency	Qualified personnel
After startup, the product does not recognize any entries made on the touchscreen	Incorrect hardware initialization	▶ Switch the product off and then on again	Qualified personnel
Axes do not count despite movement of the encoder	Incorrect connection of the encoder	▶ Correct the connection ▶ Contact the encoder manufacturer's service agency	Qualified personnel
Axes are miscounting	Incorrect settings of the encoder	▶ Check the encoder settings Page 96	Qualified personnel
Spindle error	Incorrect settings of the spindle axis	▶ Check the settings of the spindle axes Page 254	Qualified personnel, possibly OEM
	External peripherals	▶ Perform systematic error search	Qualified personnel, possibly OEM
Connection to the network is not possible	Defective connection	▶ Check the cable and the correct connection to X116	Qualified personnel
	Incorrect settings of the network	▶ Check the network settings Page 128	Qualified personnel
The connected USB mass storage device is not detected	Defective USB connection	▶ Check the correct position of the USB mass storage device in the port ▶ Use another USB port	Qualified personnel
	The type or formatting of the USB mass storage device is not supported	▶ Use another USB mass storage device ▶ Format USB mass storage device with FAT32	Qualified personnel

Fault	Cause of fault	Correction of fault	Personnel
The unit starts in recovery mode (text only mode)	Firmware error during startup	<ul style="list-style-type: none"> ▶ If this fault occurs for the first time, switch the product off and then on again ▶ If the fault recurs, contact a HEIDENHAIN service agency 	Qualified personnel
User login is not possible	Password does not exist	<ul style="list-style-type: none"> ▶ As user with higher permission level, reset the password Page 124 ▶ To reset the OEM password, contact the HEIDENHAIN service agency 	Qualified personnel

19

**Removal and
Disposal**

19.1 Overview

This chapter contains information and environmental protection specifications that must be observed for correct disassembly and disposal of the product.

19.2 Removal



Removal of the product must be performed only by qualified personnel.

Further information: "Personnel qualification", Page 27

Depending on the connected peripherals, the removal may need to be performed by an electrical specialist.

In addition, the same safety precautions that apply to the mounting and installation of the respective components must be taken.

Removing the product

To remove the product, follow the installation and mounting steps in the reverse order.

Further information: "Installation", Page 41

Further information: "Mounting", Page 35

19.3 Disposal

NOTICE

Incorrect disposal of the product!

Incorrect disposal of the product can cause environmental damage.

- ▶ Do not dispose of electrical waste and electronic components in domestic waste
- ▶ The integrated backup battery must be disposed of separately from the product
- ▶ Forward the product and the backup battery to recycling in accordance with the applicable local disposal regulations



- ▶ If you have any questions about the disposal of the product, please contact a HEIDENHAIN service agency

20

Specifications

20.1 Overview

This chapter contains an overview of the product data and drawings with the product dimensions and mating dimensions.

20.2 Product data

Device

Housing	Aluminum cast housing
Housing dimensions	200 mm x 169 mm x 41 mm For devices with ID 1089179-xx: 200 mm x 169 mm x 47 mm
Fastener system, mating dimensions	Mounting hole pattern 50 mm x 50 mm

Display

Visual display unit	<ul style="list-style-type: none"> ■ LCD Widescreen (15:9) color screen 17.8 cm (7") ■ 800 x 480 pixels
Display step	Selectable, min. 0.00001 mm
User interface	User interface (GUI) with touchscreen

Electrical data

Supply voltage	<ul style="list-style-type: none"> ■ AC 100 V ... 240 V (± 10 %) ■ 50 Hz ... 60 Hz (± 5 %) ■ Input power max. 38 W
Buffer battery	Lithium battery type CR2032; 3.0 V
Overvoltage category	II
Number of encoder inputs	3
Encoder interfaces	<ul style="list-style-type: none"> ■ 11 μA: max. current 300 mA, max. input frequency 150 kHz ■ 1 V_{PP}: max. current 300 mA, max. input frequency 400 kHz
Interpolation at 1 V _{PP}	4096-fold
Touch probe connection	<ul style="list-style-type: none"> ■ Voltage supply DC 5 V or DC 12 V ■ 5 V or floating switching output ■ 4 digital inputs ■ 1 digital output ■ Max. cable length with HEIDENHAIN cable 30 m

Electrical data

Digital inputs	For devices with ID 1089179-xx: TTL DC 0 V ... +5 V									
	<table border="1"> <thead> <tr> <th>Level</th> <th>Voltage range</th> <th>Current range</th> </tr> </thead> <tbody> <tr> <td>High</td> <td>DC 11 V ... 30 V</td> <td>2.1 mA ... 6.0 mA</td> </tr> <tr> <td>Low</td> <td>DC 3 V ... 2.2 V</td> <td>0.43 mA</td> </tr> </tbody> </table>	Level	Voltage range	Current range	High	DC 11 V ... 30 V	2.1 mA ... 6.0 mA	Low	DC 3 V ... 2.2 V	0.43 mA
Level	Voltage range	Current range								
High	DC 11 V ... 30 V	2.1 mA ... 6.0 mA								
Low	DC 3 V ... 2.2 V	0.43 mA								
Digital outputs	For devices with ID 1089179-xx: TTL DC 0 V ... +5 V Maximum load 1 k Ω Voltage range DC 24 V (20.4 V ... 28.8 V) Output current max. 150 mA per channel									
Relay outputs	For devices with ID 1089179-xx: <ul style="list-style-type: none"> ■ Max. switching voltage AC 30 V / DC 30 V ■ Max. switching current 0.5 A ■ Max. switching capacity 15 W ■ Max. continuous current 0.5 A 									
Analog inputs	For devices with ID 1089179-xx: Voltage range DC 0 V ... +5 V Resistance 100 Ω \leq R \leq 50 k Ω									
Analog outputs	For devices with ID 1089179-xx: Voltage range DC -10 V ... +10 V Maximum load 1 k Ω									
5 V voltage outputs	For devices with ID 1089179-xx: Voltage tolerance \pm 5 %, maximum current 100 mA									

Electrical data

Data interface	<ul style="list-style-type: none"> ■ 1 USB 2.0 Hi-Speed (Type A), maximum current 500 mA per USB connection ■ 1 Ethernet 10/100 Mbit/1 Gbit (RJ45)
----------------	--

Environment

Operating temperature	0 °C ... +45 °C
Storage temperature	-20 °C ... +70 °C
Relative air humidity	10 % ... 80 % RH, non-condensing
Altitude	≤ 2000 m

General information

Directives	<ul style="list-style-type: none"> ■ EMC Directive 2014/30/EU ■ Low Voltage Directive 2014/35/EU ■ RoHS Directive 2011/65/EU
Pollution degree	2
Protection EN 60529	<ul style="list-style-type: none"> ■ Front panel and side panels: IP 65 ■ Rear panel: IP 40
Mass	<ul style="list-style-type: none"> ■ 1.3 kg ■ With Single-Pos stand: 1.35 kg ■ With Duo-Pos stand 1.45 kg ■ With Multi-Pos stand: 1.95 kg ■ With Multi-Pos holder: 1.65 kg <p>For devices with ID 1089179-xx:</p> <ul style="list-style-type: none"> ■ 1.5 kg ■ With Single-Pos stand: 1.55 kg ■ With Duo-Pos stand 1.65 kg ■ With Multi-Pos stand: 2.15 kg ■ With Multi-Pos holder: 1.85 kg

20.3 Product dimensions and mating dimensions

All dimensions in the drawings are in millimeters.

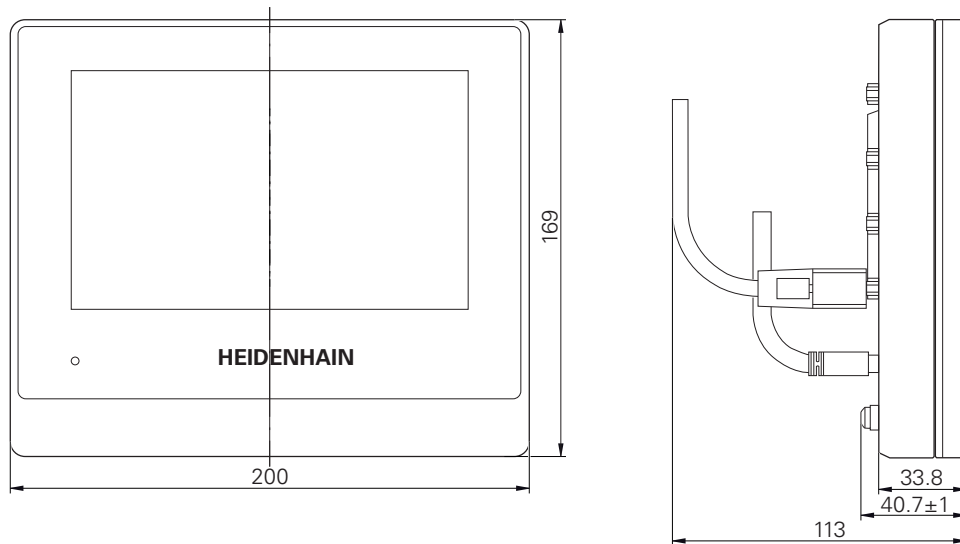

Figure 67: Housing dimensions for devices with ID 1089178-xx

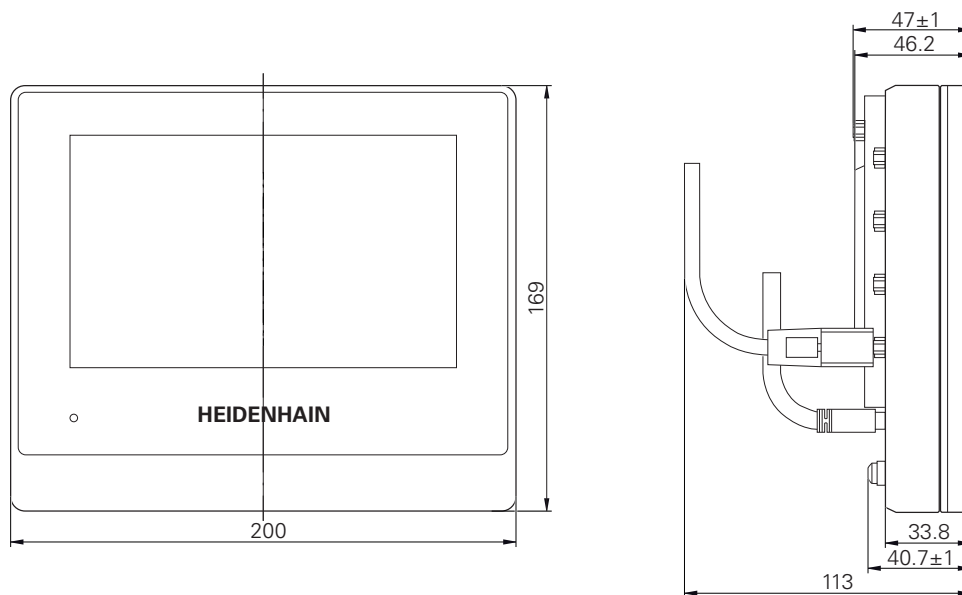

Figure 68: Housing dimensions for devices with ID 1089179-xx

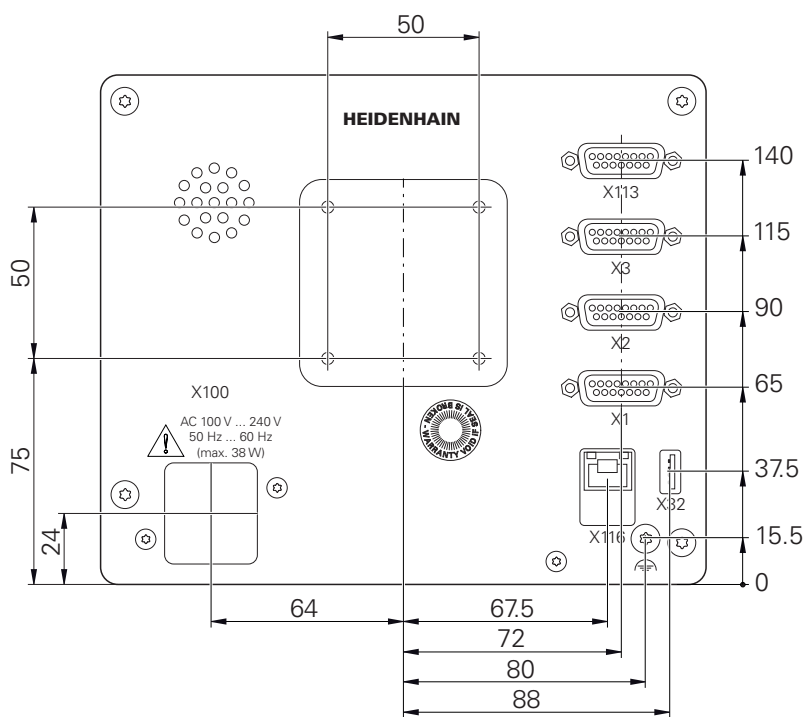

Figure 69: Dimensions of the rear panel for devices with ID 1089178-xx

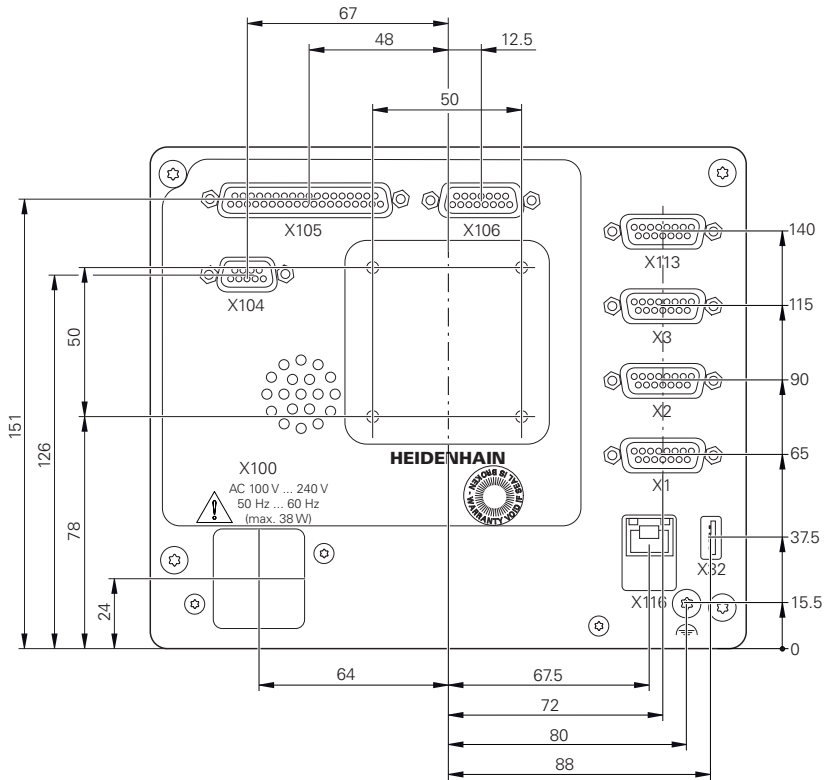

Figure 70: Dimensions of the rear panel for devices with ID 1089179-xx

20.3.1 Product dimensions with Single-Pos stand

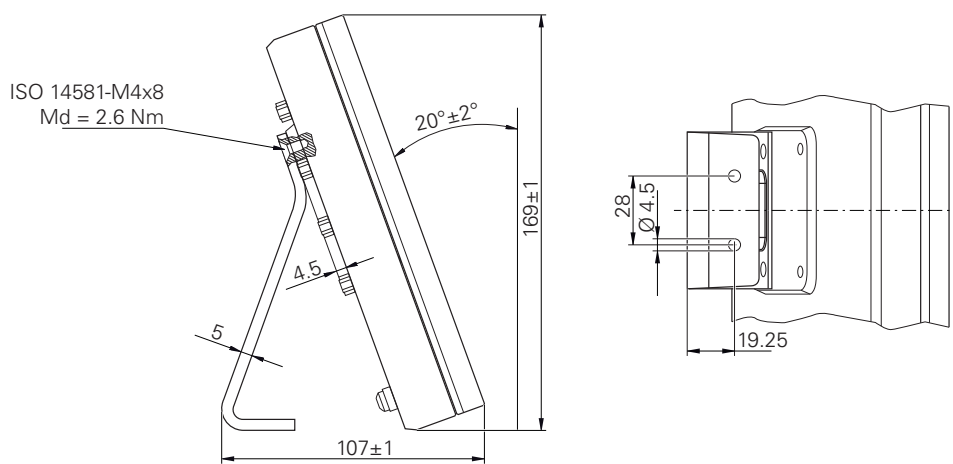

Figure 71: Product dimensions with Single-Pos stand

20.3.2 Product dimensions with Duo-Pos stand

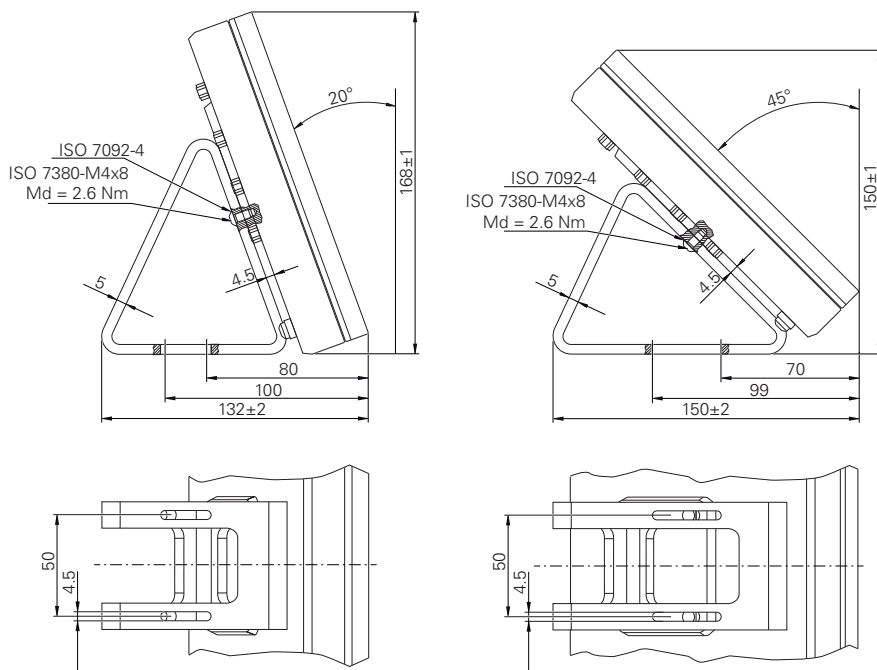

Figure 72: Product dimensions with Duo-Pos stand

20.3.3 Product dimensions with Multi-Pos stand

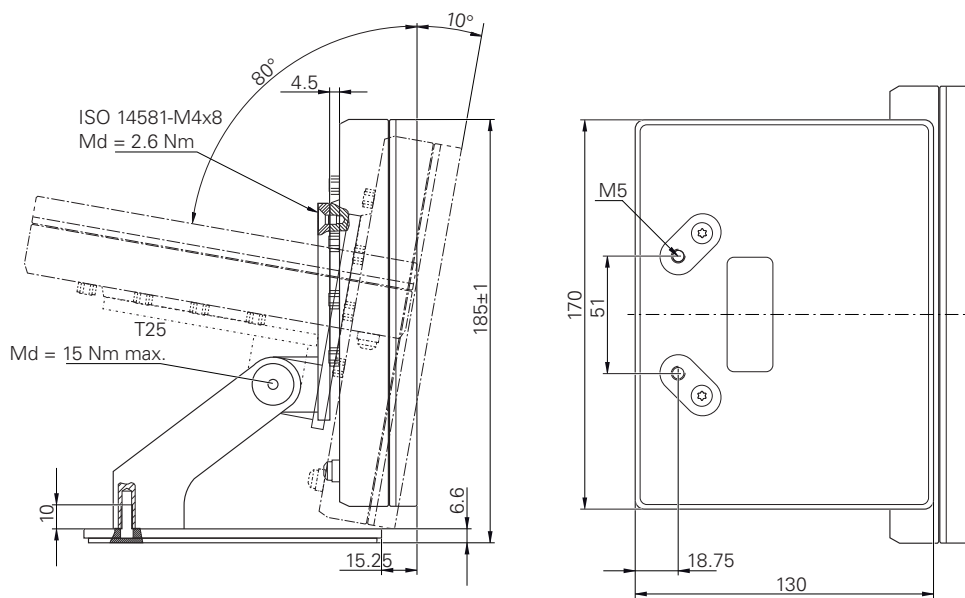

Figure 73: Product dimensions with Multi-Pos stand

20.3.4 Product dimensions with Multi-Pos holder

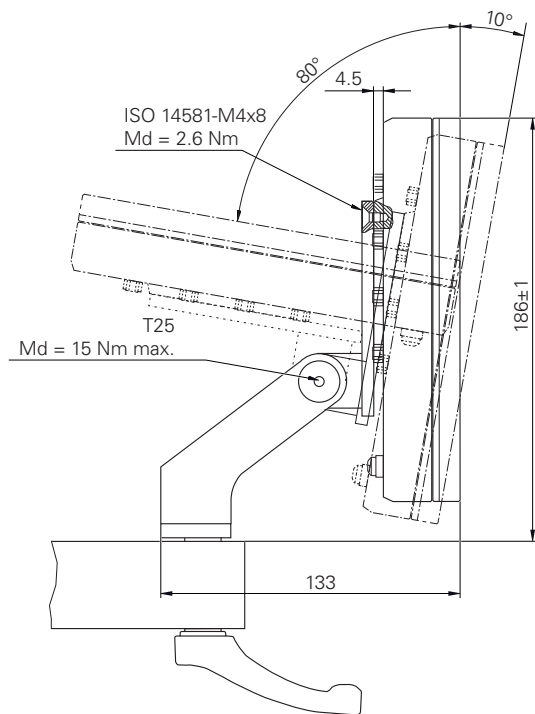

Figure 74: Product dimensions with Multi-Pos holder

21 Index

- A**
- Accessories..... 33
 - Activating the reference mark search..... 95
 - Addendum..... 18
 - Adding a startup screen..... 107
 - Ambient conditions..... 290
 - Assembly..... 36
 - Audio feedback..... 90
 - Axes
 - C..... 249
 - X, Y, Z..... 248
- C**
- Cleaning the screen..... 272
 - commissioning..... 94
 - Computer..... 54
 - Configuring axis parameters..... 96
 - Configuring network settings... 128
 - Configuring the OEM logo..... 110
 - Connecting an Ethernet printer.. 53
 - Connecting a USB printer..... 53
 - Connecting encoders..... 46
 - Connecting touch probes..... 47
 - Connection
 - Computer..... 54
 - Connection overview..... 44
 - Contour view..... 206, 214
 - CUPS..... 135
- D**
- Damage in transit..... 34
 - date and time..... 94, 123, 233
 - decimal places..... 95, 123, 234
 - Decimal separators..... 234
 - Device
 - installing..... 42
 - Documentation
 - Addendum..... 18
 - download..... 17
 - OEM..... 106
 - Dragging..... 60
 - Duo-Pos..... 38
- E**
- Electrical specialist..... 27
 - Encoders
 - configuring axis parameters... 96
 - HEIDENHAIN..... 98
 - energy saving mode..... 63
 - Enhanced printer settings..... 135
 - Error compensation
 - linear error compensation.... 101, 253
 - Methods..... 100
 - performing..... 100
 - segmented linear error compensation..... 102, 253
 - Table of supporting points... 254
- Example
- Bearing seat drawing..... 171
 - Circular hole pattern (MDI mode)..... 165, 167
 - Finishing the outside contour..... 179
 - fit (MDI mode of operation). 162
 - Flange drawing..... 154
 - Preset..... 176
 - Preset (manual operation mode)..... 156, 164
 - rectangular pocket (MDI mode of operation)..... 159
 - Roughing the outside contour..... 177
 - Setting up the lathe..... 173
 - through hole (manual operation mode)..... 157
 - Turning the recesses..... 178
 - workpiece..... 152, 170
- F**
- File
 - copying..... 221
 - deleting..... 221
 - exporting..... 223
 - importing..... 224
 - moving..... 220
 - opening..... 222
 - renaming..... 221
 - File management
 - file types..... 219
 - Menu..... 75
 - Short description..... 218
 - Firmware update..... 274
 - Folder
 - copying..... 220
 - creating..... 219
 - deleting..... 221
 - moving..... 220
 - renaming..... 220
 - Folders
 - managing..... 219
 - Folder structure..... 219
- G**
- Geared spindles..... 99
 - Gear stages
 - Configuring..... 258
 - Gestures
 - Dragging..... 60
 - Holding..... 59
 - Operation..... 59
 - Tapping..... 59
 - Ground connection, 3-wire cable 55
- H**
- HEIDENHAIN encoders..... 98
 - Holding..... 59
- I**
- Informational notes..... 22
 - Input devices
 - connect..... 53
 - Operation..... 58
 - Installation..... 42
 - Installation Instructions..... 18
 - Items supplied..... 32
- L**
- Language
 - setting..... 65
 - Lathe
 - Tool measurement..... 174
 - linear error compensation (LEC)..... 101
- M**
- Main menu..... 68
 - Maintenance plan..... 273
 - Malfunctions..... 281
 - Manual operation..... 70
 - menu..... 70
 - Manual operation mode
 - Example..... 156, 157, 164
 - MDI
 - menu..... 72
 - MDI mode
 - Example..... 165, 167
 - Scaling factor..... 207, 215
 - MDI mode of operation
 - example..... 159, 162
 - Menu
 - File management..... 75
 - Manual mode..... 190
 - manual operation..... 70
 - manual operation mode..... 182
 - MDI..... 72
 - MDI mode..... 198, 210
 - Settings..... 77
 - Switch-off..... 78
 - User login..... 76
 - Messages..... 88
 - closing..... 89
 - viewing..... 88
 - M functions
 - configuring..... 112, 247
 - configuring..... 269
 - manufacturer-specific..... 104
 - Overview..... 104
 - standard..... 104
 - mounting..... 36
 - Duo-Pos stand..... 38
 - Multi-Pos holder..... 40

- Multi-Pos stand..... 39
- Single-Pos stand..... 37
- Mouse actions
 - Dragging..... 60
 - Holding..... 59
 - Operation..... 59
 - Tapping..... 59
- Multi-Pos..... 39, 40
- N**
- network drive
 - Configuring..... 129
- O**
- Obligations of the operating company..... 28
- OEM
 - adding documentation..... 106
 - adjusting display..... 115
 - defining keyboard design..... 115
 - modifying startup screen..... 107
- OEM bar..... 86
 - Configuring..... 110
 - configuring M functions..... 112
 - displaying OEM logo..... 110
 - Functions..... 87
 - Operating elements..... 86
- Operating elements
 - add..... 62
 - back..... 62
 - close..... 62
 - confirm..... 62
 - drop-down list..... 62
 - Main menu..... 68
 - plus/minus button..... 61
 - Screen keyboard..... 61
 - slide switch..... 62
 - toggle switch..... 61
 - undo..... 62
- Operating Instructions..... 18
 - updating..... 127
- Operation
 - Audio feedback..... 90
 - Energy saving mode..... 63
 - General operation..... 58
 - Gestures and mouse actions. 59
 - Messages..... 88
 - Operating elements..... 61
 - Touchscreen and input devices..... 58
 - Wizard..... 90
- Operator..... 27
- P**
- Password
 - changing..... 93, 122, 125
 - creating..... 124
 - default password.... 65, 92, 121, 153, 170
- Personnel qualification..... 27
- Pin layout
 - encoders..... 46
 - Ethernet printer..... 53
 - line voltage..... 55
 - network..... 54
 - switching inputs..... 48
 - USB printer..... 53, 54
- Power connector..... 55
- PPD file..... 134
- Printer
 - adding network printer..... 132
 - connecting..... 53
 - enhanced settings..... 135
 - not supported..... 134
 - USB printer..... 130
- Printer drivers..... 134
- Product
 - commissioning..... 94
 - Setting up..... 123
 - Switch-off..... 64
 - Switch-on..... 63
- Product data..... 288
- Q**
- Qualified personnel..... 27
- Quick start..... 152, 170
- R**
- Reference mark search
 - Conducting..... 183, 192
 - Performing after startup..... 66
- Repackaging..... 34
- rounding methods..... 95, 123, 234
- S**
- Safety precautions..... 22, 26
 - general..... 28
 - Peripheral devices..... 28
- ScreenshotClient
 - Information..... 116
- Segmented linear error compensation (SLEC)..... 102
- Selecting the application mode.. 94
- Settings
 - Menu..... 77
 - Restoring..... 276
 - Saving..... 117, 148
- Setup..... 123
- Single-Pos..... 37
- Spindle
 - Configuring inputs and outputs..... 99
 - spindle axis..... 99
- Spindle speed programming..... 87
- setting..... 87
- Status bar..... 82
 - Adjusting settings in the quick access menu..... 83
 - Calculator..... 84
 - Operating elements..... 82
 - Stop watch..... 84
- Storage..... 34
- Switch-off
 - Menu..... 78
- Symbols and fonts used for marking text..... 23
- Symbols on the product..... 28
- T**
- Table of supporting points
 - adjusting..... 103
 - creating..... 101, 102
- Tapping..... 59
- Tool table
 - Creating..... 155, 172
- Touchscreen
 - Operation..... 58
- U**
- units of measure..... 95, 123, 234
- User
 - configuring..... 125
 - creating..... 124
 - Login..... 65
 - Logout..... 65
 - User login..... 64
 - user types..... 124
- User files
 - backing up..... 118, 149
- User ID..... 124
- User interface
 - After startup..... 67
 - Factory default setting..... 67
 - File management menu..... 75
 - Main menu..... 68
 - manual operation menu..... 70
 - MDI menu..... 72
 - Settings menu..... 77
 - Switch-off menu..... 78
 - User login menu..... 76
- User login..... 64
 - Menu..... 76
- Users
 - deleting..... 126
- W**
- Wiring switching inputs and outputs..... 48
- Wizard..... 90

22 List of Figures

Image 1:	Dimensions of rear panel of the product.....	36
Image 2:	Product mounted on Single-Pos stand.....	37
Image 3:	Cable routing on Single-Pos stand.....	37
Image 4:	Product mounted on Duo-Pos stand.....	38
Image 5:	Cable routing on Duo-Pos stand.....	38
Image 6:	Product mounted on Multi-Pos stand.....	39
Image 7:	Cable routing on Multi-Pos stand.....	39
Image 8:	Product mounted on Multi-Pos holder.....	40
Image 9:	Cable routing on Multi-Pos holder.....	40
Image 10:	Rear panel on devices with ID 1089178-xx.....	44
Image 11:	Rear panel on devices with ID 1089179-xx.....	45
Image 12:	Screen keyboard.....	61
Image 13:	The user interface in the unit's factory default setting.....	67
Image 14:	User interface (in Manual operation mode).....	68
Image 15:	Manual operation menu in the milling application mode.....	70
Image 16:	Manual operation menu in the turning application mode.....	71
Image 17:	MDI mode menu in the milling application mode.....	72
Image 18:	MDI mode menu in the turning application mode.....	73
Image 19:	MDI block dialog.....	74
Image 20:	File management menu.....	75
Image 21:	User login menu.....	76
Image 22:	Settings menu.....	77
Image 23:	Display of messages in the workspace.....	88
Image 24:	Support from the wizard for work steps.....	90
Image 25:	XML file as text database.....	108
Image 26:	The ScreenshotClient user interface.....	116
Image 27:	Tool table with tool parameters in the Milling application mode.....	138
Image 28:	Preset table with absolute positions in the Milling application mode.....	142
Image 29:	Example workpiece.....	152
Image 30:	Example workpiece– technical drawing.....	154
Image 31:	Example workpiece – finding preset D1.....	156
Image 32:	Example workpiece – drilling a through hole.....	157
Image 33:	Example workpiece – machining a rectangular pocket.....	159
Image 34:	Example workpiece – machining a fit.....	162
Image 35:	Example workpiece – finding preset D2.....	164
Image 36:	Example workpiece – drilling a circular hole pattern.....	165
Image 37:	Example workpiece – drilling a circular hole pattern.....	167
Image 38:	Example workpiece.....	170
Image 39:	Example workpiece – technical drawing.....	171
Image 40:	Finishing tool parameters.....	173
Image 41:	Datum.....	173
Image 42:	Example workpiece – finding the preset.....	176
Image 43:	Example workpiece – roughing the outside contour.....	177
Image 44:	Example workpiece – turning the recesses.....	178

Image 45:	Example workpiece – finishing the outside contour.....	179
Image 46:	Manual operation menu.....	182
Image 47:	Manual operation menu.....	190
Image 48:	Upper limit for spindle speed dialog.....	191
Image 49:	MDI menu.....	198
Image 50:	Schematic display of the bolt hole circle block.....	200
Image 51:	Schematic display of the row of holes block.....	201
Image 52:	Schematic display of the rectangular pocket block.....	202
Image 53:	Example of a block in the MDI mode.....	204
Image 54:	Simulation window with contour view.....	206
Image 55:	Distance to go with position view with graphic positioning aid.....	207
Image 56:	Example – MDI block.....	208
Image 57:	Example – Execution of an MDI block with scaling factor.....	208
Image 58:	MDI menu.....	210
Image 59:	Upper limit for spindle speed dialog.....	211
Image 60:	Example of a block in the MDI mode.....	213
Image 61:	Simulation window with contour view.....	214
Image 62:	Distance to go with position view with graphic positioning aid.....	215
Image 63:	Example – MDI block.....	216
Image 64:	Example – Execution of an MDI block with scaling factor.....	216
Image 65:	File management menu.....	218
Image 66:	File management menu with preview image and file information.....	222
Image 67:	Housing dimensions for devices with ID 1089178-xx.....	291
Image 68:	Housing dimensions for devices with ID 1089179-xx.....	292
Image 69:	Dimensions of the rear panel for devices with ID 1089178-xx.....	292
Image 70:	Dimensions of the rear panel for devices with ID 1089179-xx.....	293
Image 71:	Product dimensions with Single-Pos stand.....	293
Image 72:	Product dimensions with Duo-Pos stand.....	294
Image 73:	Product dimensions with Multi-Pos stand.....	294
Image 74:	Product dimensions with Multi-Pos holder.....	295

HEIDENHAIN

DR. JOHANNES HEIDENHAIN GmbH

Dr.-Johannes-Heidenhain-Straße 5

83301 Traunreut, Germany

☎ +49 8669 31-0

FAX +49 8669 32-5061

E-mail: info@heidenhain.de

Technical support FAX +49 8669 32-1000

Measuring systems ☎ +49 8669 31-3104

E-mail: service.ms-support@heidenhain.de

NC support ☎ +49 8669 31-3101

E-mail: service.nc-support@heidenhain.de

NC programming ☎ +49 8669 31-3103

E-mail: service.nc-pgm@heidenhain.de

PLC programming ☎ +49 8669 31-3102

E-mail: service.plc@heidenhain.de

APP programming ☎ +49 8669 31-3106

E-mail: service.app@heidenhain.de

www.heidenhain.de

SALES & SERVICE:

A Tech Authority, Inc.

13745 Stockton Ave.

Chino CA 91710

909-614-4522

sales@atechauthority.com

