

Renishaw plc
New Mills, Wotton-under-Edge,
Gloucestershire GL12 8JR
United Kingdom

T +44 (0)1453 524524
F +44 (0)1453 524901
E uk@renishaw.com
www.renishaw.com

SALES & SERVICE:
A Tech Authority, Inc.
13745 Stockton Ave.
Chino CA 91710
909-614-4522
sales@atechauthority.com

RENISHAW 
apply innovation

PH10M motorised probe head

Increase throughput with a PH10M

The PH10M is a motorised probe head designed to increase throughput by giving DCC machines the added capability of probe re-orientation. This enables the probe to inspect features at different angles without the need for frequent, time-consuming, stylus cluster changes.

PH10M is compatible with a range of both contact and non-contact scanning sensors and touch trigger probes, allowing the size, position and form of critical features to be determined.

Renishaw's autochange systems, used in conjunction with PH10M, provide fast repeatable probe and extension bar exchange, without the need for re-qualification of the stylus tip, helping to maximise productivity.

The PH10M is an established product that provides a cost effective probing solution for many applications.



Key benefits

Increased throughput

The ability of the PH10M to index automatically reduces the number of stylus changes required, thereby increasing the throughput of your CMM. Indexing is faster than stylus changing.

Improved accuracy

The PH10M can achieve 0.5 μm repeatability at 62 mm radius, providing accurate positioning even when using long extensions.

Increased reach and flexibility

Extension bars up to 300 mm long together with the full range of Renishaw autojoint and M8 probes can be used with PH10M.

Innovations

Repeatable kinematic location

The PH10M uses six point kinematic location for each of its 720 positions making its locking mechanism extremely repeatable.

The Renishaw autojoint

This patented feature allows repeatable automatic probe exchange without the need for stylus re-qualification.

UCC compatibility

The PH10M can be used in conjunction with Renishaw's UCC controller family providing a comprehensive solution.

Specification

Weight	645 g (22.7 oz)
CMM mounting	Shank (a variety of shanks are available from Renishaw)
Probe mounting	Renishaw autojoint (multiwired) M8 threaded probes can be used with PH10M via a PAA probe adaptor
Suitable controller	PHC10-2 (RS232 and IEEE versions available) or, PHC10/50 UCC daughter card
Repeatability of position	0.5 μ m (0.00002 in) specified at a distance of 62 mm (2.44 in)
Cycle time	
75° move:	2.5 seconds
90° move:	3.5 seconds
Total angular movement	
A axis	0° to 105° in 7.5 steps
B axis	0° to \pm 180° in 7.5 steps
Total number of positions	720
Maximum drive output torque	0.45 Nm
Maximum extension bar	300 mm (11.8 in) using PAA3 probe adaptor
Temperature range	
Operating:	10 °C to 40 °C (50 °F to 104 °F)
Storage:	-10 °C to 70 °C (14 °F to 158 °F)
Hand control unit	HCU1
Autochange systems	ACR1/ACR3

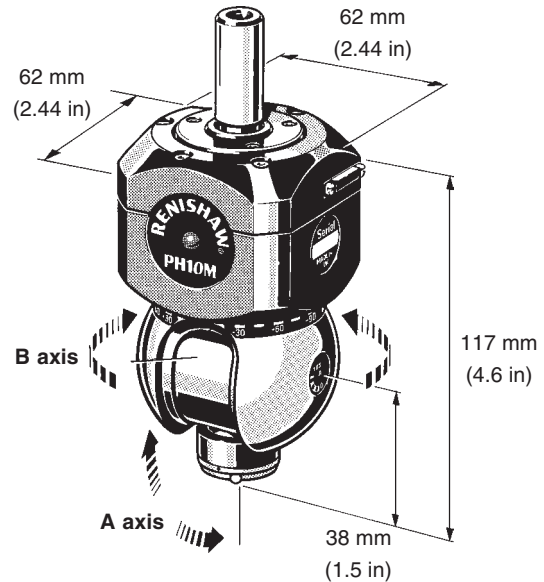

Additional information

Other variants of the PH10M are also available. These are PH10MQ and PH10T. For further details on these related products refer to www.renishaw.com/PH10.

A variety of shanks are also available for PH10M depending on your CMM. In order to select the correct PH10 kit for your machine refer to www.renishaw.com/PH10M.

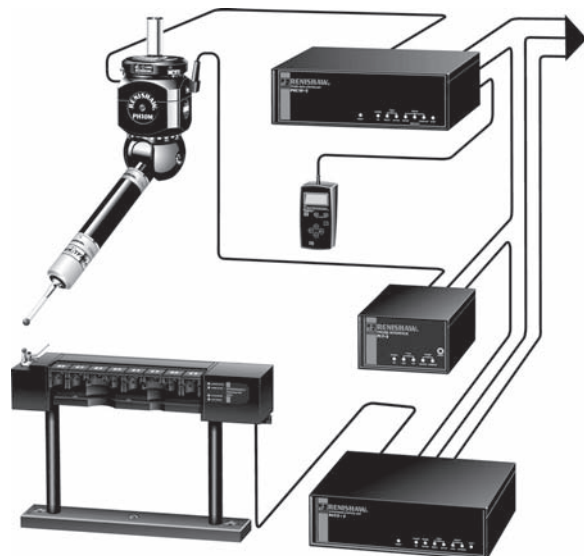

For worldwide contact details, please visit our main website at www.renishaw.com/contact