

# QC 300 Series

## *Video Edge Detection and Crosshair Systems*



### **SALES & SERVICE:**

**JA Tech Authority, Inc.**  
13745 Stockton Ave.  
Chino CA 91710  
909-614-4522  
sales@atechauthority.com

# ***User's Guide***

# **QC-300 Series**

## ***User's Guide***

**Video Edge Detection Systems**  
**QC-320, QC-321, QC-323, QC-324**

Metronics, Inc.  
30 Harvey Road  
Bedford, New Hampshire 03110  
Telephone (603) 622.0212  
Facsimile (603) 623.5623  
sales@metronics.com  
www.metronics.com



# **QC-300 Series Video Edge Detection Systems User's Guide**

Published by  
Metronics, Inc.  
30 Harvey Road  
Bedford, New Hampshire 03110  
[www.Metronics.com](http://www.Metronics.com)

User's Guide part number: 11A10568  
Publishing date: March, 2006  
Printed in United States of America  
Copyright © 2005 by Metronics, Inc., Bedford, New Hampshire

QC-300 software version: 1.0

All information set forth in this document, all rights to such information, any and all inventions disclosed herein and any patents that might be granted by employing the materials, methods, techniques or apparatus described herein are the exclusive property of Metronics Inc., Bedford, New Hampshire.

Terms, conditions and features referenced in this document are subject to change without notice.

No part of this document may be reproduced, stored in a retrieval system, or transmitted in any form or by any means, electronic, mechanical, photocopying, recording, or otherwise, without prior written permission of Metronics, Inc.. Requests to Metronics, Inc. for permission should be addressed to the Technical Services Department, Metronics, Inc., 30 Harvey Road, Bedford, New Hampshire 03110.

## **Limit of liability and disclaimer of warranty**

While this guide was prepared with great care, Metronics makes no representations or warranties with respect to the accuracy or completeness of the contents of this book and specifically disclaims any implied warranties of merchantability or fitness for a particular purpose. The advice, methods and instructions contained in this book might not be suitable for your situation. When in doubt regarding suitability, you are encouraged to consult with a professional where appropriate. Metronics shall not be liable for any loss of profit or any damages, including but not limited to special, incidental, consequential or other damages.

## **Trademarks**

Metronics and QC-300 are registered trademarks of Metronics, Inc. and its subsidiaries in the United States and other countries.

## Conventions & Terms

QC-300 refers to any of the QC-300 series of instruments. System refers to the QC-300 and the measuring devices connected to it.

## Icons

This guide uses the following icons to highlight information:



### WARNING

The raised hand icon warns of a situation or condition that can lead to personal injury or death. Do not proceed until the warning is read and thoroughly understood. Warning messages are shown in bold type.



### CAUTION

The exclamation point icon indicates a situation or condition that can lead to equipment malfunction or damage. Do not proceed until the caution message is read and thoroughly understood. Caution messages are shown in bold type.



### NOTE

The note icon indicates additional or supplementary information about an activity or concept. Notes are shown in bold type.

## Safety & Maintenance Considerations

General safety precautions must be followed when operating the system. Failure to observe these precautions could result in damage to the equipment, or injury to personnel.

It is understood that safety rules within individual companies vary. If a conflict exists between the material contained in this guide and the rules of a company using this system, the more stringent rules should take precedence.

Additional safety information is included on the next page and in [Chapter 2: Installation](#).



## WARNINGS

**Unplug the QC-300 from the electrical outlet before cleaning.**

The QC-300 is equipped with a 3-wire power plug that includes a separate ground connection. Always connect the power plug to a 3-wire grounded outlet. The use of accessories that remove the third grounded connection such as a 2-wire power plug adapter create a safety hazard and should not be permitted. If a 3-wire grounded outlet is not available, ask your electrician to provide one.

**Do not open the QC-300 enclosure. There are no user-serviceable components or assemblies inside.**

## General Maintenance

Unplug the QC-300 from the wall outlet and seek the assistance of a qualified service technician if:

- The power cord is frayed or damaged or the power plug is damaged
- Liquid is spilled or splashed onto the enclosure
- The QC-300 has been dropped or the exterior has been damaged
- The QC-300 exhibits degraded performance or indicates a need for service some other way

### ***Cleaning the enclosure***

Use only a cloth dampened with water and a mild detergent for cleaning the exterior surfaces. Never use abrasive cleaners, and never use strong detergents or solvents. Only dampen the cloth, do not use a cleaning cloth that is dripping wet. Instructions for cleaning the touch screen are different and are given below.

### ***Cleaning the touch screen***

The touch screen should be cleaned as described below to prevent scratching or wearing the screen surface and to prevent liquids from leaking into the enclosure.

Use only a soft, lint-free cloth dampened with water for cleaning the touch screen. Never use abrasive cloths or paper towels. Never use abrasive cleaners, and never use detergents or solvents. Only dampen the cloth, do not use a cleaning cloth that is dripping wet. Never spray the screen.

If the screen is badly soiled, the cloth can be dampened with a 50:50 mixture of isopropyl alcohol and water. Remember, only dampen the cloth, do not use a cleaning cloth that is dripping wet, and never spray the screen.

## Accuracy & Precision

Measurement accuracy is determined by many factors, such as the resolution of the encoders connected to input axes. Generally, the display resolution of the QC-300 can exceed encoder resolutions. Setting the display resolution to exceed the encoder resolution does not increase measurement accuracy.

# Contents

Chapter 1	Overview	
	Overview of QC-300 features and functions .....	1
Chapter 2	Installation	
	Unpacking the QC-300 .....	5
	Assembling the mounting stand .....	6
	Safety considerations .....	6
	Power cord and plug .....	6
	Electrical wiring and connections .....	6
	Location and mounting .....	7
	Power surge suppressor.....	7
	Connecting axis encoders.....	7
	Connecting the optional footswitch .....	8
	Connecting a printer.....	9
	Connecting a computer .....	9
	Connecting camera lighting and zoom.....	10
	Connecting a video input .....	10
	Warranty registration form.....	11
	Repackaging for shipment.....	11
Chapter 3	User Interface	
	Introduction .....	13
	Measurement functions .....	14
	Selecting a measurement type.....	14
	Accessing programming functions .....	15
	Accessing part lighting adjustment tools .....	16
	Command buttons and wide keys .....	17
	Feature list.....	18
	LCD Screen functions.....	19
	Number keys .....	20
	System functions .....	21
	Undo.....	21
	MX (Magnification).....	21
	mm/in .....	21
	Setup .....	22
	Printing reports and transmitting data .....	23
	LCD ON/OFF and deleting feature data .....	24

## Chapter 4 Quick Start Demonstration

Starting program recording .....	26
Selecting a probe .....	26
Creating part skew and datum references .....	27
Creating a part skew.....	27
Creating a datum zero point.....	28
Probing a datum zero point.....	28
Constructing a datum zero point.....	29
Measuring features.....	31
Measuring a circle with crosshairs.....	31
Measuring a circle with the multiple edge probe.....	32
Applying tolerances to feature measurements .....	34
Printing a report.....	36
Stopping the program recording.....	37
Running the program.....	37

## Chapter 5 Probes

Preparing to use video probes .....	40
System and part condition.....	40
Selecting video magnification.....	40
Adjusting light control .....	40
Adjusting video image contrast and brightness .....	43
Using video probes.....	46
Selecting a probe .....	46
Selecting a probe color .....	47
Specifying probe data collection parameters .....	48
Crosshair probe data collection parameters.....	49
Edge probe data collection parameters.....	50
Collecting feature data .....	51
The auto-enter function.....	51
Crosshair probes .....	52
Manual probing (crosshairs).....	52
Automatic probing (crosshairs) .....	53
Single edge probe .....	54
Manual probing (single edge).....	54
Automatic probing (single edge) .....	55
Multiple edge probe.....	56
Probe seeding.....	56
Probing a line.....	57
Probing a circle.....	58
Probing an arc.....	60

Seeding to avoid erroneous data .....61  
 Recovering from data errors .....62

Chapter 6 Measuring

Measurement activities.....66  
 The measurement process .....66  
     Establishing the measurement reference.....67  
         Leveling the part (optional) .....67  
         Skewing the part .....68  
         Creating a datum zero point.....69  
             Probing a datum zero point.....69  
             Constructing a datum zero point.....70  
 Probing and measuring features .....73  
     Probing with Measure Magic .....73  
     Probing specific feature types.....74  
         Probing a single specific feature type.....74  
         Probing multiple specific feature type.....74  
     Probing process.....75  
         Supported feature types .....75  
         Backward/forward annotation .....76  
     Probing with crosshairs and video edge detection.....76  
     Probing specific feature types.....77  
         Probing points.....77  
         Probing lines .....78  
         Probing arcs .....79  
         Probing slots .....81  
         Probing rectangles .....82  
         Probing distances.....83  
         Probing angles .....84  
 Constructing features .....85  
     Point constructions.....85  
         Point constructed from a point.....85  
         Point constructed from a point and a line .....85  
         Points constructed from an arc and a line.....86  
         Points constructed from a line .....87  
         Point constructed from two lines .....88  
         Points constructed from a distance .....88  
         Point constructed from a distance and a point.....89  
         Point constructed from a circle.....89  
         Points constructed from a circle and a line.....90  
         Points constructed from two circles.....91  
         Point constructed from a slot .....92



Point constructed from a rectangle .....	92
Point constructed from an angle .....	92
Point constructed from an arc .....	93
Point constructed from multiple features.....	93
Line constructions .....	94
Line constructed from a line .....	94
Line constructed from two points .....	94
Lines constructed from a point and a line.....	95
Line constructed from a distance.....	95
Lines constructed from a point and a circle .....	96
Line constructed from a point and a slot .....	97
Line constructed from a point and a rectangle.....	97
Lines constructed from a point and an arc.....	98
Lines constructed from two lines.....	99
Line constructed from a line and a distance .....	100
Lines constructed from a line and a circle .....	100
Lines constructed from a line and a slot .....	101
Lines constructed from a line and an arc .....	101
Line constructed from a line and an angle.....	102
Lines constructed from a line and a rectangle .....	102
Lines constructed from two circles.....	103
Lines constructed from a circle and an arc .....	104
Lines constructed from a circle and a slot .....	105
Line constructed from a slot .....	105
Line constructed from two slots .....	105
Lines constructed from a circle and a rectangle .....	106
Lines constructed from a slot and an arc .....	106
Lines constructed from a rectangle and an arc .....	107
Lines constructed from a slot and a rectangle .....	107
Lines constructed between two rectangles .....	108
Line constructed from a rectangle .....	110
Line constructed from multiple features .....	110
Distance constructions .....	111
Distance constructed from a distance .....	111
Distances constructed from two points.....	111
Distances constructed from a point and a line .....	112
Distances constructed from a point and a rectangle .....	112
Distances constructed from a point and a circle .....	113
Distance constructed from a point and a slot.....	114
Distances constructed from a point and an arc .....	115
Distance constructed from a line .....	116
Distance constructed from a line and a rectangle .....	116

Distances constructed from two lines .....	117
Distances constructed from a line and a circle .....	118
Distances constructed from a line and an arc .....	119
Distance constructed from a line and a slot .....	120
Distance constructed from two distances .....	120
Distances constructed from two circles .....	121
Distances constructed from a slot and a circle.....	122
Distances constructed from a rectangle and a circle.....	122
Distances constructed from an arc and a circle .....	123
Distance constructed from two slots.....	124
Distances constructed from a slot and an arc.....	124
Distances constructed from a rectangle and an arc.....	125
Distances constructed from a slot and a rectangle.....	125
Distances constructed between two rectangles.....	126
Distances constructed from two arcs .....	127
Circle constructions .....	128
Circle constructed from a circle.....	128
Circles constructed from two lines .....	128
Circle constructed from a circle and a distance .....	129
Circle constructed from two circles .....	129
Circle constructed from multiple features .....	130
Arc constructions .....	131
Arc constructed from an arc .....	131
Arc constructed from an arc and a distance.....	131
Arc constructed from multiple features .....	132
Angle constructions .....	133
Angle constructed from an angle.....	133
Angle constructed from two lines.....	134
Creating features .....	135
Creating a point.....	135
Creating a line.....	136
Creating a circle.....	136
Creating an arc .....	137
Creating a slot .....	137
Creating a rectangle .....	138

## Chapter 7 Tolerancing

Applying tolerances to features.....	141
Selecting a feature.....	141
Displaying the tolerance screen .....	141
Selecting a tolerance type .....	141
Selecting a specific tolerance.....	142

Entering nominal, limit or tolerance values.....	142
Omitting a tolerance category.....	143
Tolerance types .....	144
Bidirectional .....	144
Points .....	144
Lines .....	144
Circles and arcs.....	145
Slots and rectangles .....	145
True position.....	146
Points and lines.....	146
Circles and arcs.....	146
MMC/LMC (Material condition) .....	147
MMC Circles and arcs.....	147
LMC Circles and arcs.....	148
Runout.....	149
Roundness.....	149
Concentricity.....	149
Straightness.....	149
Parallelism .....	150
Perpendicularity.....	150
Angle.....	150
Width .....	151

## Chapter 8 Programming

Creating programs.....	153
Starting program recording.....	154
Entering a program title (or user message).....	155
Measuring a skew and creating a datum (including a message).....	156
Measure a feature (including a message).....	157
Applying a tolerance .....	158
Reporting results .....	158
Stopping the program recording .....	159
Editing Programs.....	160
Editing existing steps .....	160
Editing magnifications.....	160
Editing tolerances .....	161
Editing brightness and contrast.....	162
Editing light intensities .....	163
Editing user prompt messages .....	164
Appending new program steps to an existing program .....	165
Running programs.....	167
Archiving and retrieving programs .....	168

Deleting programs ..... 168

Chapter 9 Communication

Connecting to a computer ..... 169  
     Sending data to a computer ..... 170  
 Connecting a printer ..... 171  
     Printer format strings ..... 171  
     Report formats ..... 171  
     Printing a report ..... 172  
         Printing feature measurement data ..... 172  
         Printing QC-300 system settings ..... 173  
 RS232 connector pin designations ..... 174  
 ASCII Code table ..... 174

Chapter 10 Setup

The Setup Menu ..... 176  
     Accessing and using the Setup Menu ..... 176  
         Entering the supervisor password ..... 177  
         Selecting items from the Setup Menu ..... 178  
         Selecting setup parameter choices ..... 178  
         Entering and deleting setup data ..... 178  
         Storing a parameter and advancing to the next step ..... 179  
         Leaving the setup menu ..... 179  
 Essential setup requirements ..... 180  
 Setup screen descriptions ..... 180  
     Language screen ..... 181  
         Specifying the displayed language ..... 181  
     Supervisor screen ..... 182  
         Entering the supervisor password ..... 182  
         Keeping setup privileges until the power is cycled ..... 182  
         Hiding setup parameters from unauthorized personnel ..... 182  
         Limiting access to program functions ..... 182  
         Saving and loading settings ..... 183  
     Encoders screen ..... 184  
         Selecting an axis to configure ..... 184  
         Specifying encoder resolution ..... 184  
         Specifying encoder type ..... 184  
         Selecting reference marks ..... 185  
             None ..... 185  
             Manual ..... 185  
             Single ..... 185  
             Absolute ..... 185

Setting a new machine zero reference .....	186
Reversing the encoder count direction .....	186
Enabling axis error messages.....	186
Squareness screen .....	187
SLEC screen.....	188
LEC or SLEC, which is right for my application? .....	188
LEC (Linear error correction) .....	188
SLEC (Segmented linear error correction) .....	190
VED screen .....	193
Specifying minimum probed points.....	193
Specifying light settling time.....	193
Specifying contrast threshold .....	193
Locking the contrast threshold.....	194
Enabling axis-zeroing on the video DRO .....	194
Enabling user access to magnification calibrations .....	194
Displaying image controls .....	195
Performing camera skew calibrations.....	195
Magnifications screen.....	196
Adding video magnifications.....	196
Deleting video magnifications .....	196
Calibrating video magnification pixel size .....	197
Calibrating with a circle artifact .....	197
Calibrating with a straight edge.....	198
Performing video parcentric and parfocal calibrations.....	200
Measure screen.....	203
Annotation .....	203
Minimum points required for a feature measurement .....	203
Retaining feature data through a power cycle .....	204
Locking features to their original datums .....	204
Specifying signed distances .....	205
Startup zero .....	205
Display screen.....	206
Display resolution .....	206
Default units of linear measure.....	207
Radix for numeric displays .....	207
Angular units of measure.....	207
Time formats.....	207
Date formats.....	207
Screen saver delay .....	208
Display mode switching .....	208
Video DRO alpha blending .....	209

Print screen.....	210
Specifying a data type.....	210
Specifying a data destination .....	210
Lines per page.....	210
Buffer page .....	211
Specifying dividing lines .....	211
Labeling axes on display printouts .....	211
Printing units of measure on reports .....	211
Parallel communication retries .....	211
Ports screen.....	212
Baud rate.....	212
Word length .....	212
Stop bits .....	212
Parity.....	212
EOC delay.....	212
EOL delay .....	212
Clock screen.....	213
Sound screen .....	214
Miscellaneous screen .....	215
Return to DRO threshold.....	215
Touchscreen calibration rows and columns.....	215
Calibrating the touchscreen .....	216
Touch screen cursor.....	216
Touch screen repeat delay .....	216
Touch zone size .....	217
Screen contrast and brightness.....	217

## Chapter 11 Problem solving

Symptoms, probable causes and solutions.....	220
No image is visible on the LCD screen .....	220
Values displayed on the LCD screen are incorrect.....	220
Reports are not printed or are incomplete.....	222
Reports are printed incorrectly.....	222
Data cannot be transmitted to a computer.....	223
Getting help from your distributor.....	223

## Chapter 12 Reference material

Product specifications .....	225
Electrical .....	225
Environmental.....	225
Dimensions .....	225
LCD.....	225

ENC tests .....	225
Footswitch wiring .....	226
RS-232 connector wiring .....	227
Lighting/Zoom connector wiring .....	227
Tolerances .....	228
Concentricity tolerance .....	228
Reference Features.....	228

## Chapter 13 Common Options

Remote footswitch .....	229
Remote keypad .....	229
Serial cable.....	229
Arm mounting bracket.....	229
Arm mounting bracket adapter .....	229
WinWedge software .....	229

# Chapter 1: Overview

The Quadra-Chek 300 series is a family of advanced digital readout systems for performing 2, 3 and 4 axis measurements at very high levels of precision and accuracy. Dimensional inspection of components can be made using toolmaker's microscopes and video measurement systems as part of in-line production activities or final quality inspection.

Feature points are entered manually using crosshairs or video edge detection, or automatically using the multiple video edge detection probe. Feature type can automatically be determined by the system when using Measure Magic. Part level and skew compensation can be performed on misaligned parts prior to measurements that eliminates the need for time-consuming fixturing.

The intuitive interface will be familiar to users of the QC-200 and other Metronics digital readouts. Operators will find the QC-300 easy to understand and use thanks to the large color touch screen LCD display.

The color LCD displays alphanumeric and graphic information for the current measurement, part features and measurement data clearly on one screen, eliminating the need to page or scroll for information.

Touch screen controls select the feature to be measured, change operating and display modes, zero axes, and configure setup parameters. Touch screen controls change to support measurement-specific functions displayed on the LCD screen.

Front panel keys enter numeric data, turn the LCD on or off and send data to a printer or computer. Two wide keys located over the LCD can quickly be pressed without looking at the front panel to

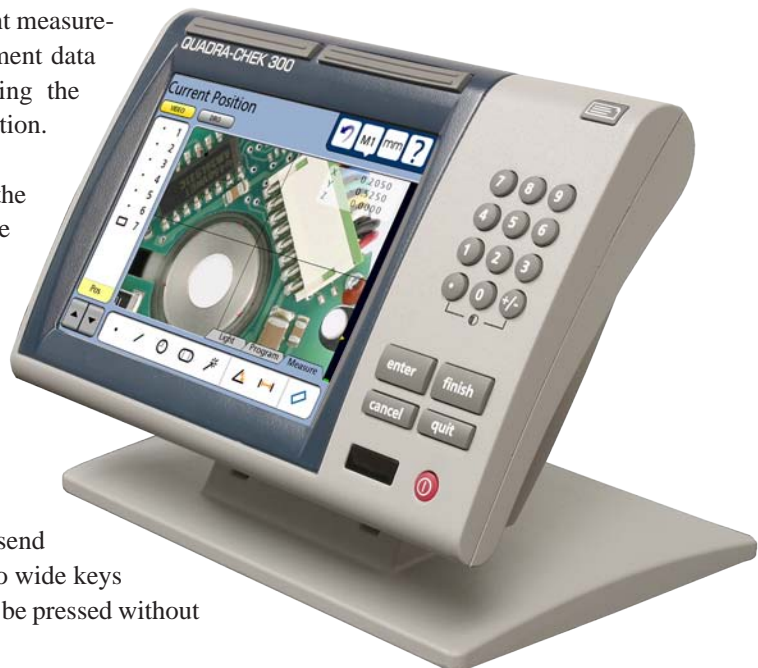





initiate frequently used functions programmed by the user. All front panel keys provide tactile sensory feedback, and key-press operations can be configured to generate an audible sound.

Speaker and external speaker jack outputs are provided that can be adjusted for quiet or noisy environments. Ear phones can be plugged into the external speaker jack to facilitate silent operation in quiet environments.

Video camera inputs are displayed on the color LCD and support NTSC and Pal formats as composite video and S-video signals.

Measurements viewed on the LCD can be transmitted to a PC over USB or RS-232 ports or to a printer over the USB port.

Sequences of key-presses used to perform measurements can be recorded and stored as programs. These programs can be replayed later to perform complete measurement sequences. Sequences can be as simple as measuring a line, or can be expanded to include skew adjustment, datuming, the measurement of multiple features, tolerancing and printing reports of measurement results.

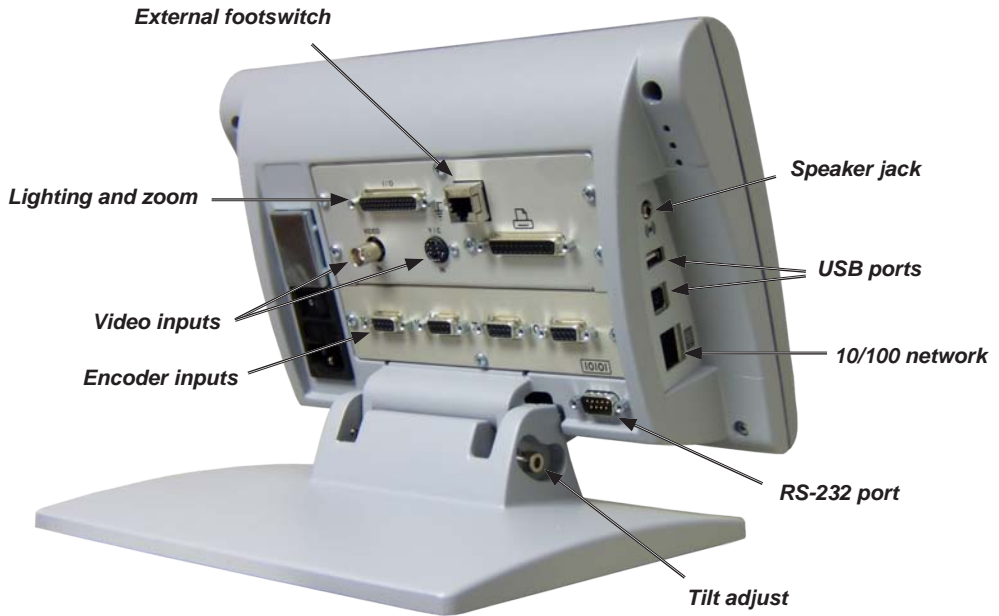

The compact ergonomic design and adjustable-tilt front panel of the QC-300 allow users to locate and mount the instrument in a wide variety of environments that accommodate nearly any viewing requirement. The tilt front panel can be adjusted and secured in any convenient position. Rubber feet on the bottom prevent slipping when the system is not permanently bolted to a work surface using the bolt holes provided in the mounting stand.

An optional foot switch is available for operation when the user is not close to the front panel.

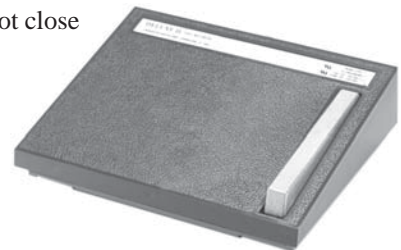

# Chapter 2: Installation

The QC-300 is easy to install in a variety of basic and advanced measurement applications. This chapter describes how to unpack and install the QC-300. Repackaging instructions are also included for return shipments and for OEM customers that are configuring a QC-300 and shipping it to an end-user.

## Unpacking the QC-300

Carefully remove the contents of the shipping carton.



### NOTE

**Save the carton and packaging materials in case future reshipment becomes necessary.**

Inspect the components listed below for shipping damage. The contents of the carton includes:

- QC-300 instrument
- Power cord
- Mounting stand and hardware
- Warranty registration card

Video systems can also include optional cables:

- Light control cable
- Video cable

Shipments of other optional equipment in separate cartons can include:

- Remote keypad
- Foot switch
- RS-232 serial cable
- Taltech's WinWedge® software

If any components were damaged in shipment, save the packaging materials for inspection and contact your shipping agent for mediation. Contact your Metronics distributor for replacement parts.

## Assembling the mounting stand

The QC-300 is secured to the swivel slots of the mounting stand by a shoulder screw, a cap screw and associated washers.

Assemble the QC-300 to the mounting stand as shown. Tighten the shoulder screw (1), and then tighten the cap screw (5) and washers (3 & 4) so that the QC-300 can be adjusted to various tilt positions and will be secure in any position.

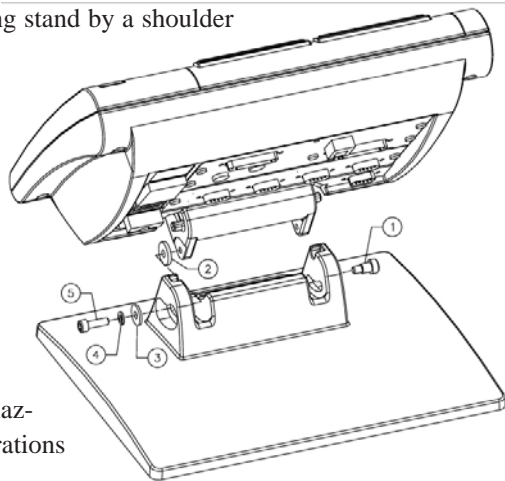

## Safety considerations

The QC-300 is completely enclosed and no potentially hazardous outputs are available to the user. Safety considerations are related to power connections and physical mounting.



### WARNING

If the QC-300 falls from its mounting location, serious personal injury or damage to the equipment can result.

## Power cord and plug

Do not locate the power cord where it can be walked on or will create a tripping hazard. Connect the 3-wire power plug to only a 3-wire grounded outlet. Never connect 2-wire to 3-wire adapters to the power cord or remove the third ground wire to fit the plug into a 2-wire electrical outlet. Modifying or overriding the third-wire ground creates a safety hazard and should not be permitted.



### WARNING

Always disconnect the power cord from the source of AC power before unplugging it from the QC-300 power connector. The AC voltage available at electrical outlets is extremely dangerous and can cause serious injury or death.

## Electrical wiring and connections

Perform regular inspections of all connections to the QC-300. Keep connections clean and tight. Locate cables away from moving objects. Do not create tripping hazards with power cords, input/output cables and other electrical wiring.

Use shielded cables to connect to the serial RS-232 port. Make certain that cables are properly terminated and firmly connected on both ends.

## Location and mounting

Secure the QC-300 to a stable surface.

## Power surge suppressor

Connect the QC-300 to power through a high-quality power surge suppressor. Surge suppressors limit the amplitude of potentially damaging power line transients caused by electrical machinery or lightning. When a surge suppressor is not used, power line transients can more easily corrupt system memory or damage circuits.



### CAUTION

**Industrial quality surge suppressors are recommended. Surge suppressors found in inexpensive power strips are often insufficient to protect the QC-300 from damage.**

## Connecting axis encoders

Axis encoders are attached to standard interface connectors on the rear of the QC-300. Many encoder interfaces are available to match the wide variety of encoders that can be used with the QC-300. The type of axis encoder connectors will vary depending on the application. Encoder inputs are specified as analog or TTL at the time of purchase and cannot be changed in the field.

- 1 Verify that the QC-300 is off.
- 2 Connect the axis encoders tightly to their connectors. An axis label is provided near each connector. Do not overtighten the connector screws.

Encoder inputs must be configured later using the Encoder setup screen. Please refer to [Chapter 10: Setup](#) for details regarding encoder setup.



## Connecting the optional footswitch

The optional foot switch is connected to the RJ-45 connector on the left side of the QC-300.

- 1 Verify that the QC-300 is off.
- 2 Connect the foot switch to the RJ-45 connector on the rear connector panel.

*Footswitch connector*

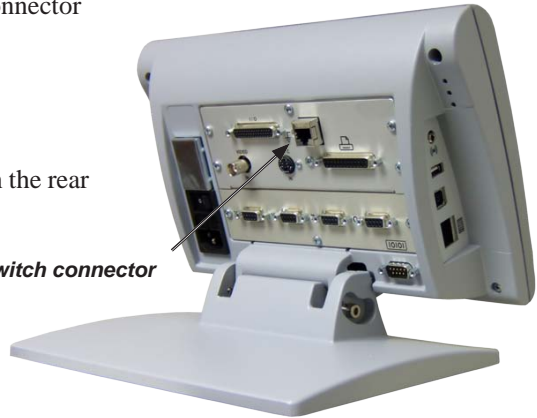

## Connecting a printer

The QC-300 supports certain HP USB printers. Printer models must be specified when the QC-300 is ordered, or approved by Metronics later.

- 1 Verify that the QC-300 and printer power are off. Connect the USB printer to the USB Type A port on the side of the enclosure.
- 2 Make sure the USB cable plug is fully inserted.

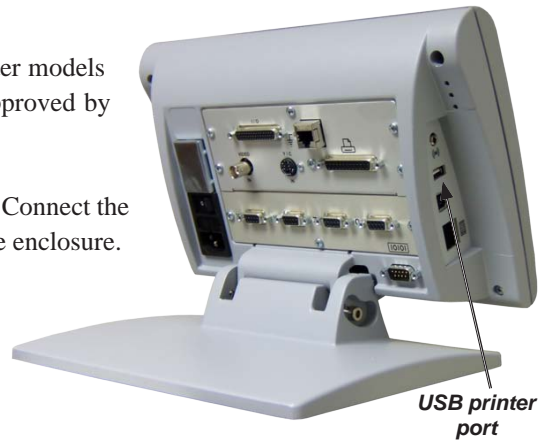

## Connecting a computer

- 1 Verify that the QC-300 and computer power are off.
- 2 Connect a computer COM port to the QC-300 RS-232 serial port using a standard straight-through serial cable (Metronics part number 11B12176). Make sure the cable connectors are tight, but do not overtighten the connector screws.
- 3 Apply power to the computer, and then the QC-300. The default QC-300 settings for communication over the RS-232 serial port are shown here.

- Baud rate: 9600
- Parity: None
- Data bits: 7
- Stop bits: 1
- Flow control: Hardware

- 4 Launch the computer application that will be used to communicate with the QC-300, and configure the communication properties of the COM port to match those of the QC-300.



## Connecting camera lighting and zoom

The QC-300 supports top, back and ring lighting for image illumination. The lighting output connections are made to an external light control box through the 44 pin Lighting/Zoom connector. The 0 to 5 Volt zoom control output connections to a zoom amplifier are also made through the Lighting/Zoom connector.

- 1 Verify that the QC-300, camera light control box and zoom amplifier are off.
- 2 Tighten the lighting/zoom cable to the lighting/zoom connector on the back panel. Do not overtighten the connector screws.

The lighting and zoom outputs must be configured using the Lighting and Magnifications setup screens. Please refer to [Chapter 10: Setup](#) for details regarding lighting and zoom setup.

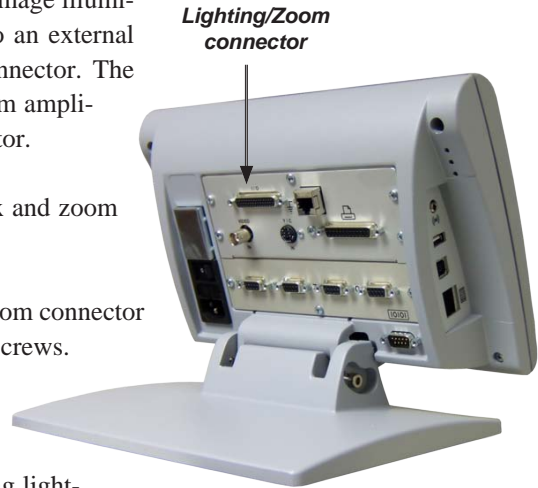

## Connecting a video input

The QC-300 supports composite and S-Video inputs for NTSC and PAL systems.

- 1 Verify that the QC-300 and video camera are off.
- 2 Connect the video input to the composite or S-video connector. Make sure the connector is properly oriented and do not force the connector into place.

The camera input must be configured later in the VED setup screen. Please refer to [Chapter 10: Setup](#) for details regarding video setup.

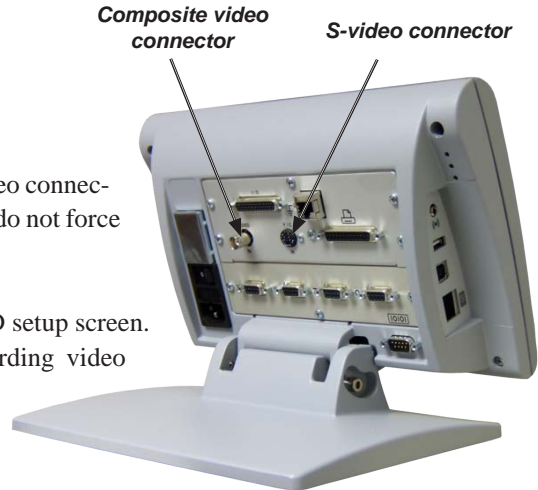



## Warranty registration form

The warranty registration form included in the shipping carton should be completed and mailed as soon as possible. Also record the purchase and warranty information here so that it will be readily available later to support any necessary interactions with distributor or factory technical support personnel.

QC-300 model number	QC-300 serial number
Purchased from	Date received
Software version number	

The software version can be found in the Hardware setup screen. Refer to [Chapter 10: Setup](#) for screen descriptions.

## Repackaging for shipment

Repackage the QC-300 in the original packaging as received from the factory, or equivalent. It is not necessary to ship the base when shipping the QC-300 for repair.



### CAUTION

**The original packaging must be duplicated and the LCD must be inserted face-up to prevent damage to the LCD screen.**

Pay special attention to the following instructions:

- 1 Connect any loose mounting hardware to the QC-300 instrument
- 2 Repackage the foam and cardboard carton inserts as originally shipped from the factory.
- 3 Place the QC-300 into shipping carton with the LCD facing up.
- 4 Replace the warranty card and slip sheets found at the top of the carton. The “Before you begin” slip sheet should be inserted last.

## What's next?

Proceed to [Chapter 10: Setup](#) to configure your QC-300 for use. Follow the instructions for *Essential Setup* as a minimum.

# Chapter 3:

## User Interface

The QC-300 user interface consists of hardware front panel buttons and number keys that work in cooperation with software menus, buttons, and data fields shown on the color LCD touch screen. The hardware/software interface is divided into the function areas listed and shown below.

- Measurement functions
- Command buttons and wide keys
- Feature list
- LCD Screen functions
- Number keys
- System functions
- Printing reports and sending data
- LCD ON/OFF or delete features

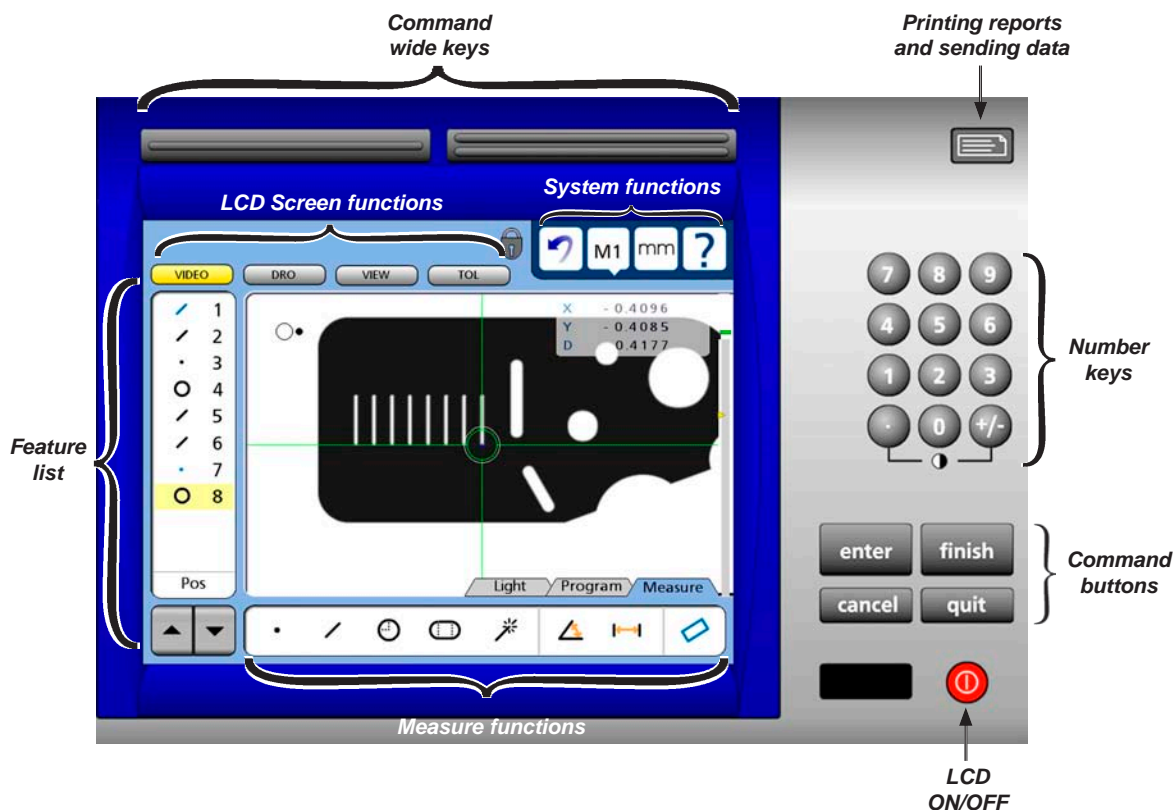

## Measurement functions

The measurement functions are divided into three tabbed areas:

- Measure functions      Select a measurement type, such as circle or line
- Program functions      Record, edit or play back a program of measurement steps
- Light functions          Adjust lighting for measurements on video systems

### Selecting a measurement type

Measurement types are selected from the Measure tab. Touch the Measure tab to display icons for the different measure types.

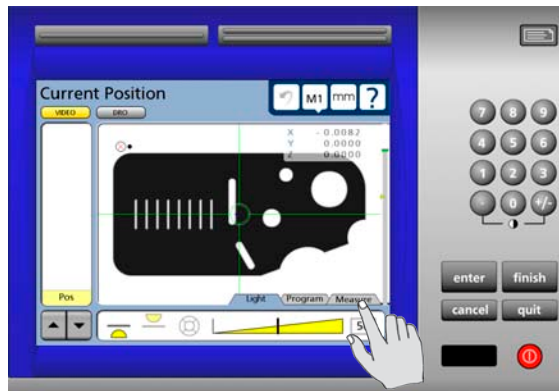

*Touch the Measure tab...*

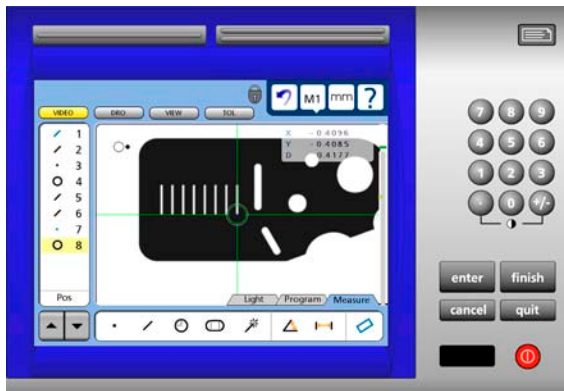

*to display measure types*

Touch a measure icon to select the desired measure type. In some cases, such as when selecting circles and slots, related measure types will also be presented as shown in this example of touching the circle icon to display the arc measure type.

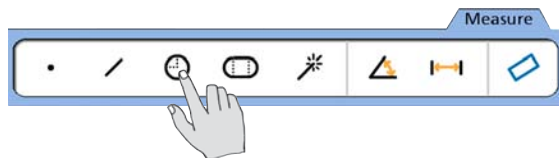

*Touching the circle measure icon...*

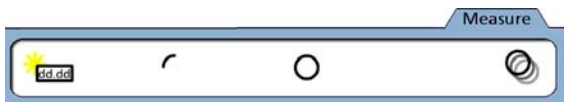

*also provides access to the arc measure type*



#### NOTE

Details regarding performing measurements and the use of measurement tools are provided in [Chapter 6: Measuring](#).

### Accessing programming functions

Programming functions are accessed from the Program tab. Touch the Program tab to display programming tools.

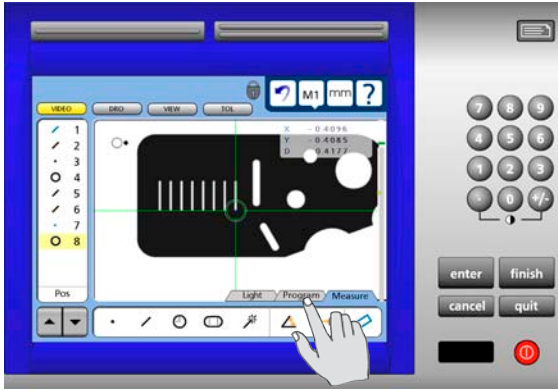

Touch the Program tab...

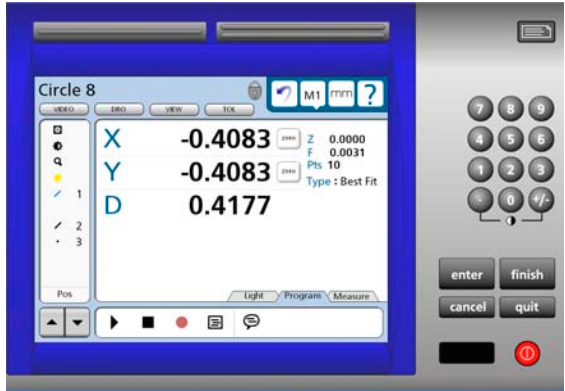

to display programming tools

Touch a program tool icon to play, record, edit, copy, stop or add a user message to a measurement program. Completed program steps are shown in the feature list.







Programming tools shown before recording



Programming tools shown during recording

-  Run a program
-  Record a program
-  Open edit mode
-  Copy a program

-  Run a program
-  Stop recording
-  Open edit mode
-  Include user message



**NOTE**

Details regarding programming and the use of programming tools are provided in **Chapter 8: Programming**.

## Accessing part lighting adjustment tools

Lighting adjustment tools are accessed from the Light tab. Touch the Light tab to display the lighting adjustment tools.

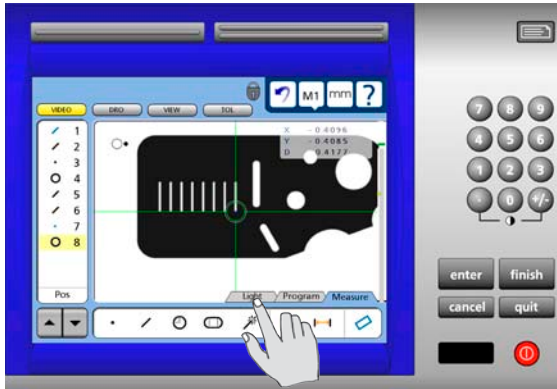

*Touch the Light tab...*



*to display light adjustment tools*

Touch an icon to select the desired light adjustment. Systems can be ordered with adjustments for back-lights, surface lights and camera ring lights. Each area of lighting is adjusted by a slider that brightens or attenuates the light intensity of the selected area from 0 to 100 % in steps of 1 %.

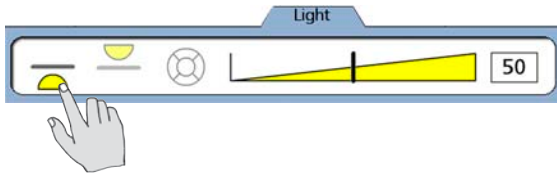

*Touch the Light area icon...*

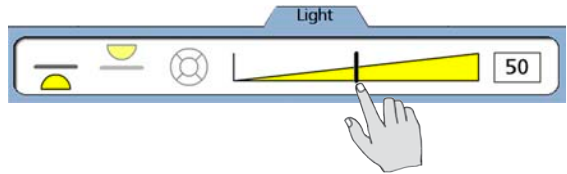

*and adjust the light intensity slider*

The system can be configured in the VED setup screen to include Image controls in addition to the light adjustments. Touch the Light/Image control tab repeatedly to toggle between the light and image controls.

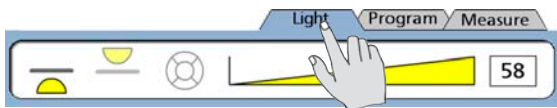

*Touch the Light tab...*

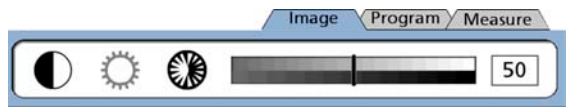

*to display Image controls*



### NOTE

Details regarding the use of light adjustment and image control tools are provided in **Chapter 6: Measuring**.

## Command buttons and wide keys

The command buttons and wide keys are primarily used to support measurement and setup activities. The command wide keys are duplicates of the Enter and Finish functions which are the most frequently used command buttons, and can be located and pressed easily by the operator without looking at the front panel.



- Enter Enters a point (or points) into a measurement, or enters a value into a measurement data field, tolerance data field, communication data field or a setup data field
- Finish Completes a measurement, tolerancing or setup session
- Cancel Removes the last point from a measurement, deletes a feature from the feature list, or removes the last character from a data field
- Quit Cancels a measurement in progress, ends a setup session without saving new settings and ends a programming session



### NOTE

Details regarding the use of the command keys are provided in [Chapter 6: Measuring](#), and are distributed throughout the remainder of this user guide.

## Feature list

The feature list provides access to all features that have been measured, constructed or created. Measurements are selected by touching them in the feature list, and then viewed or toleranced in other screens.

When the feature list contains too many entries to be displayed simultaneously, the arrow keys at the bottom of the list are used to scroll up or down to display all the entries.

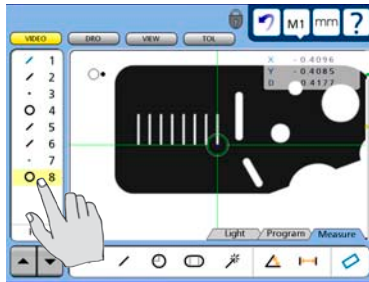
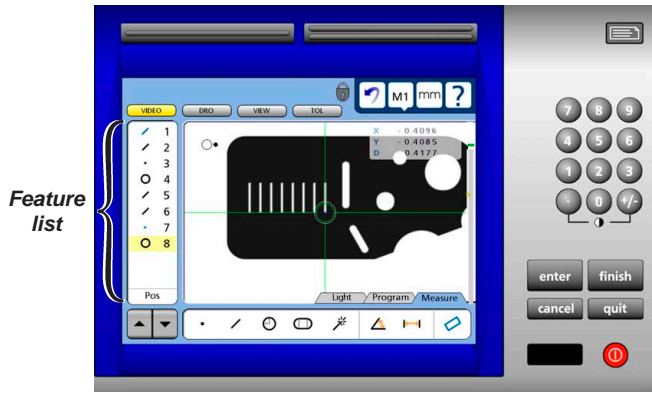

*Selected measurements can be...*

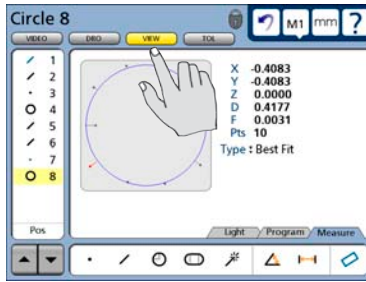

*viewed...*

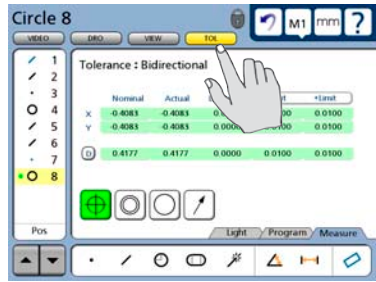

*or toleranced in other screens*

When recording, playing or editing programs, the program steps are also shown in the feature list.



### NOTE

Details regarding the use of the feature list are distributed throughout the remainder of this user guide.

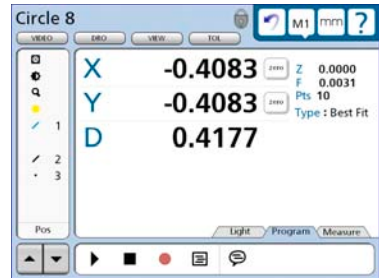

## LCD Screen functions

The LCD functions are used to select the screen that will be presented on the color touch LCD, generally in support of the next operator activity



Touch a button to select the desired screen.

- Video Displays the camera's view
- DRO Displays the digital readout
- View Displays the selected feature's data
- TOL Displays the tolerance screens for entering and editing tolerances

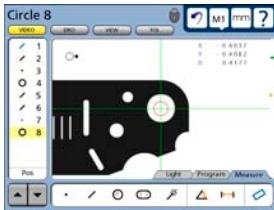
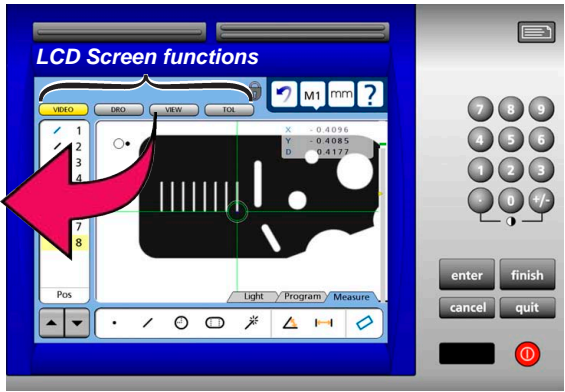

Video screen

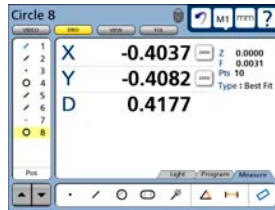

DRO screen

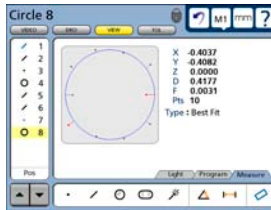

View screen

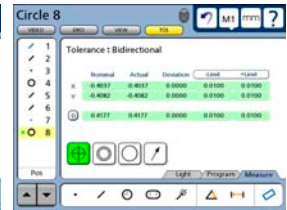

Tol screen



### NOTE

Details regarding the use of the four basic screen types are distributed throughout the remainder of this user guide.



## Number keys

The number keys are used to enter data into feature constructions and creations, tolerances, programs, and setup data fields.

Numbers are entered into data fields in the conventional manner, and can be erased when necessary by backspacing over them using the Cancel button.

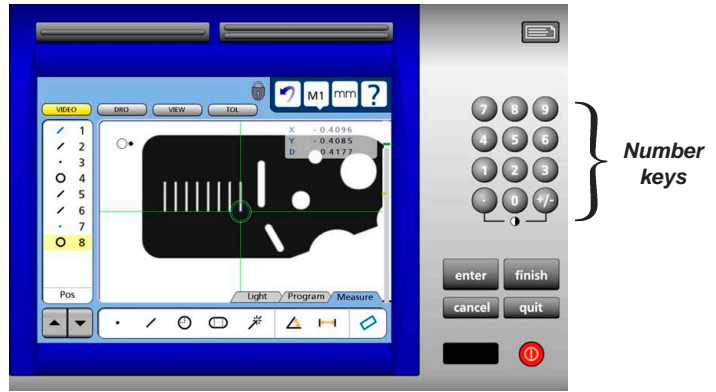

### NOTE

Details regarding the use of number keys are distributed throughout the remainder of this user guide.

## System functions

System functions support a wide variety of measurement and setup activities. These include:

### Undo

The Undo function is very similar to the Windows undo function and erases the last measurement or feature list activity step. The Undo function only erases the last step, sequences of steps cannot be erased using undo.

### MX

The MX (shown here as M1) function provides access to a drop down list of available video magnifications. Touching the MX button shows the list of available magnifications. Touch the desired magnification to select it.

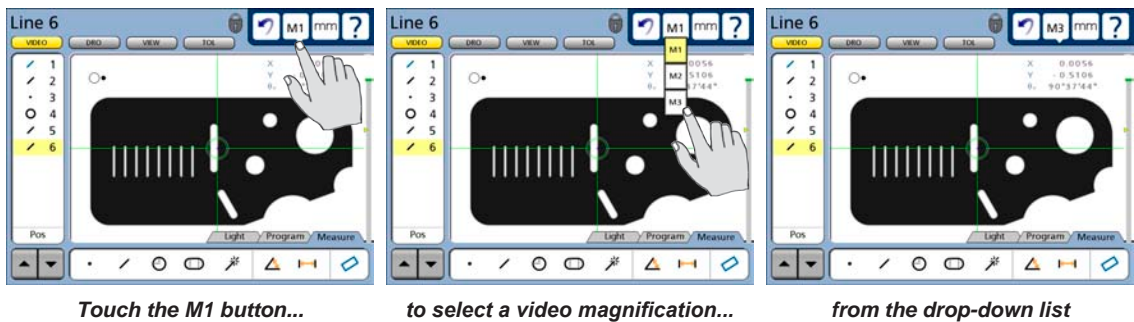

### mm/in

The mm/in function toggles the linear unit of measure between metric and English. Touch the mm/in button to toggle the units of measure.

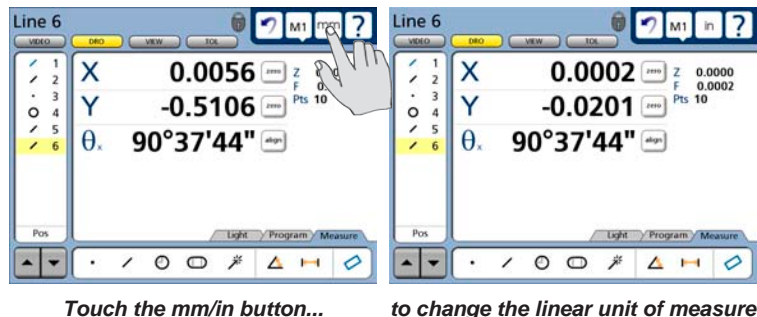

## Setup



The setup function provides access to all of the system setup screens required for configuring QC-300 measurement and operation. Touch the setup button to display the setup screen and menu. Access to the setup menu is given through two introductory screens that show the software version, the system options and a caution regarding the use of setup functions.

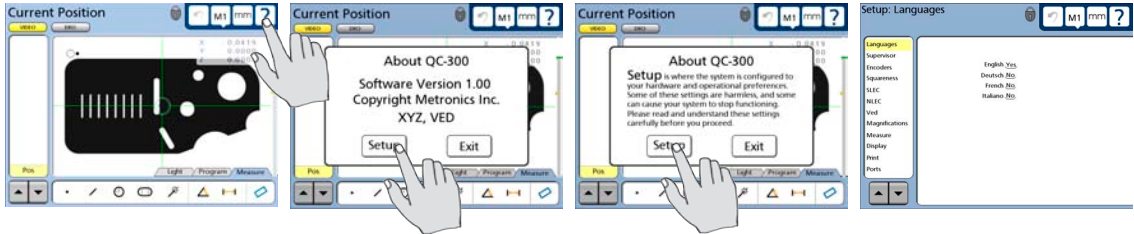

Setup screen tools will be made available to those who can provide a valid supervisor password.

**NOTE**

Detailed descriptions of all setup functions and tools are contained in **Chapter 10: Setup.**

## Printing reports and sending data

Measurement data shown on the DRO screen or contained in the feature list can be printed in reports on the USB port or sent to a computer over the RS232 serial port. In either case, the printing of reports and the transmission of measurement data is initiated by pressing the Print button.



**NOTE**

Report printing and data transmission are configured in the **Print setup screen** described in **Chapter 10: Setup**. Printing and data transmission are described in **Chapter 9: Communication**.

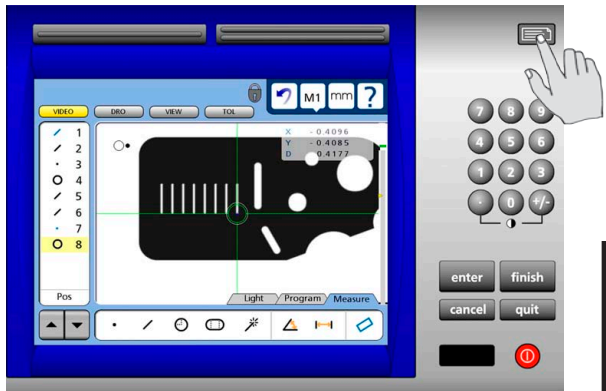

## LCD ON/OFF and deleting feature data

The LCD screen can be turned off without cycling power when the QC-300 will not be used for an extended period, but it is desirable to retain the original machine zero encoder references. Press the red LCD ON/OFF button to toggle the LCD on and off.

When the LCD ON/OFF button is pressed, the operator is given an opportunity to erase all feature measurement data and resume operation without turning the LCD off. If the operator presses the Enter key to delete feature data, the system will ask for confirmation. If confirmation is given, the feature data and datums will be permanently deleted.

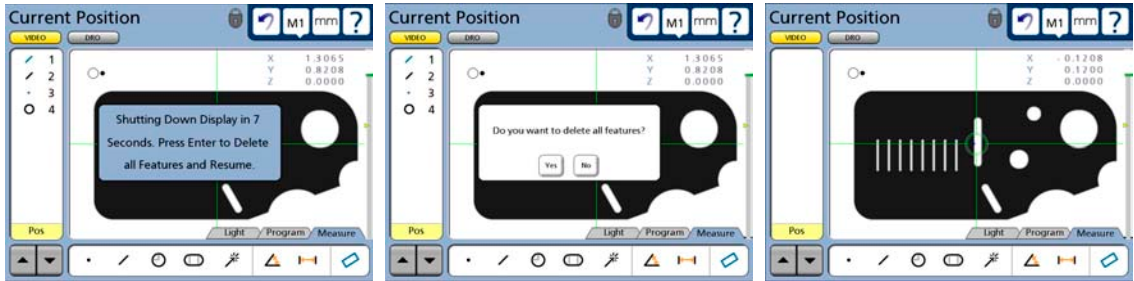
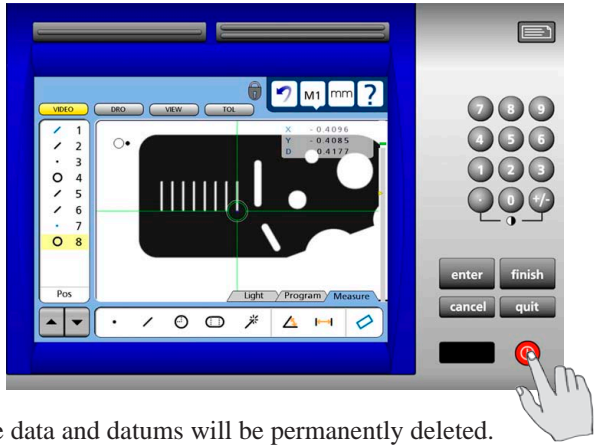

*You will be asked to press Enter... and asked to confirm the delete... then the feature data will be deleted*



### CAUTION

Delete feature data only when you have saved the data in a report, transmitted it to a computer file or are sure that you no longer need them. Once the data are deleted, they cannot be restored.

# Chapter 4: Quick Start Demonstration

This chapter demonstrates the operation of the QC-300 system. The demonstration is provided as a means of quickly helping experienced operators to use the system. This demonstration will be most helpful if you perform the measurements and other activities as you follow along.

The demonstration will use the Metronics QC Quickie slide to create a part skew and datum, measure some part features, apply a few tolerances, print a tolerance report and save all these activities as a program that can be recalled and run again later.



*The QC Quickie slide is shipped with each system*

When the program is run on a manual system, the series of required points will be indicated by a green arrow that moves over the part outline in the Part View or Video window. The user need only probe locations indicated by the arrow to complete measurements.

The demonstration will show measurements being performed on a video stage using a video edge detection probe. However, the same measurements could also be performed on a microscope or comparator using cross-hairs.

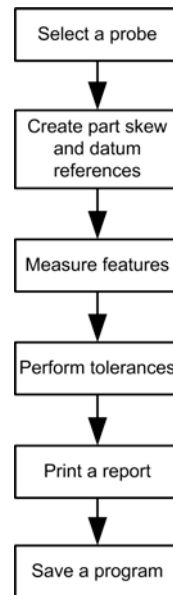

**Summary of the Quick Start Demonstration**

Detailed information regarding datuming and measuring is contained in [Chapter 6: Measuring](#). Information regarding tolerancing is contained in [Chapter 7: Tolerancing](#). Report printing is discussed in [Chapter 9: Communication](#). Information regarding programming is contained in [Chapter 8: Programming](#).

## Starting program recording

To record the following activities as a program:

1 Touch the Program tab to display the program screen and then touch the Record icon. The text entry screen will be displayed.

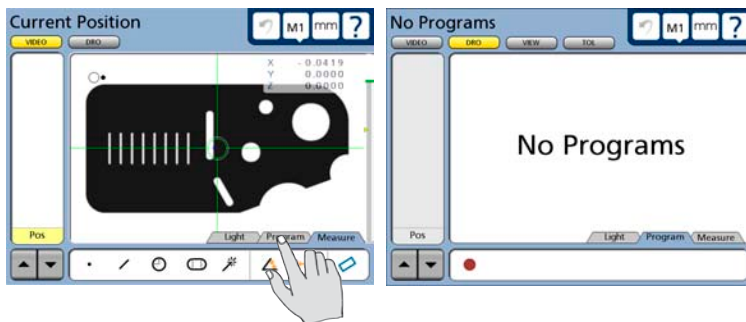

2 Enter a program title and press the Finish key. The DRO or Video screen will be displayed. Touch the Measure tab to begin measurements.

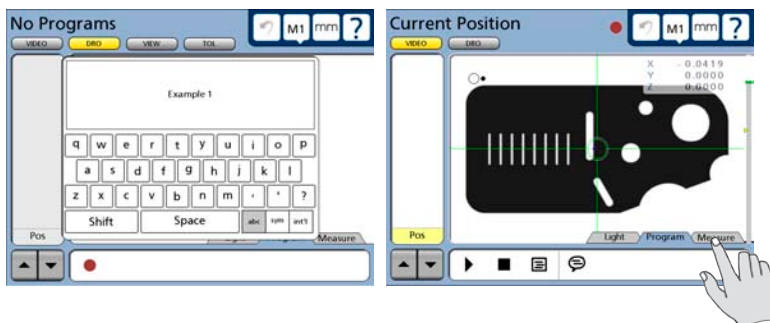

## Selecting a probe

To select a new probe:

1 Select a new probe type by touching any part of the current probe on the Video window. The four probe choices will be shown on the probe pop-up screen.

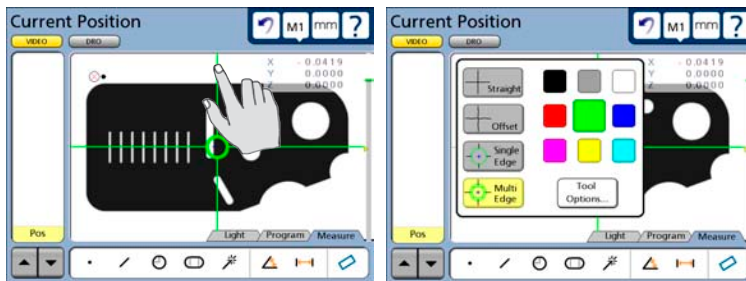

2 Touch the desired probe type button. The probe pop-up screen will close and the new probe will be displayed. In this example the straight crosshair probe is selected.

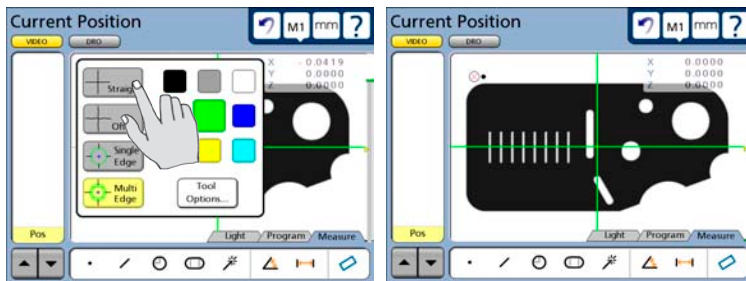

### NOTE

More information

regarding preparing and using probes is contained in [Chapter 5: Probes](#).

## Creating part skew and datum references

When the part is misaligned (twisted) in the X-Y plane, errors can be generated during the measurement process. These errors can be eliminated by creating a skew alignment for the part.

The skew alignment includes a precise measurement of the part misalignment. Once the misalignment is known to the system, subsequent feature measurements are automatically compensated to eliminate misalignment errors. Measurement data in the DRO will reflect measurements of a perfectly aligned part.

### Creating a part skew

To skew the part:

- 1 Touch the Skew/Level Measure icon.

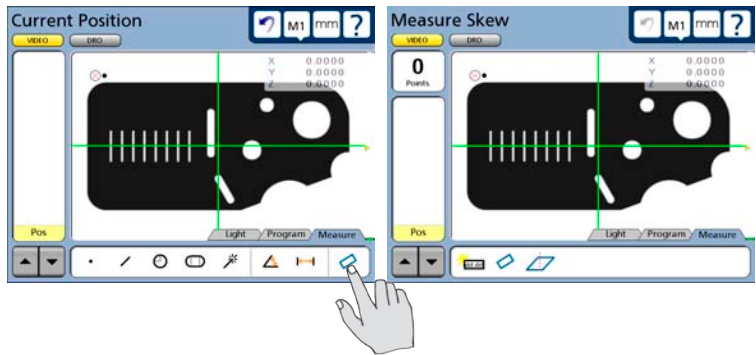

- 2 Perform the skew alignment by probing 2 or more points well distributed along the entire length of the desired part reference edge. Press the Enter key to enter each point. Press the Finish key to complete the Skew measurement. The skew line feature will be added to the Features list in blue.

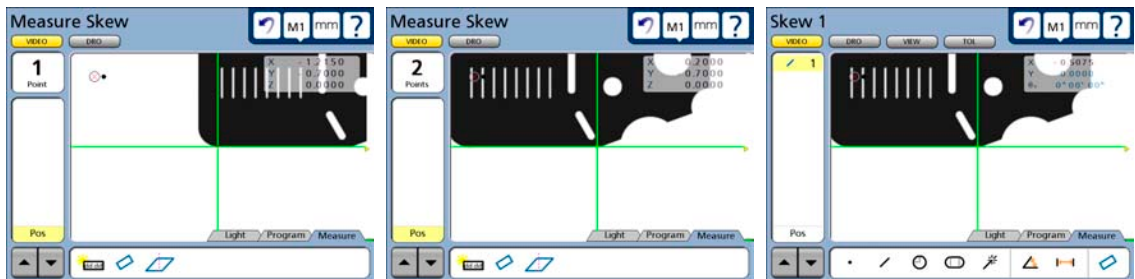



## Creating a datum zero point

Creating the datum zero point is the final step in establishing a valid Cartesian or polar coordinate system for subsequent measurements. The datum zero point will be used as the origin of Cartesian or polar systems. The datum zero point can be positioned in any location that satisfies the measurement requirements of the user and can be created by probing a point or by constructing a point from parent features.

### Probing a datum zero point

The datum zero point can sometimes be created directly by probing a point. Simple probing is more often possible when the part is precisely aligned in the stage.

To probe a datum zero point:

- 1 Touch the Point Measure icon. Probe the desired point for the datum zero, and then press the Finish key. In this example, the lower left corner of the QC Quickly slide was probed. The point will be added to the Features list in blue.

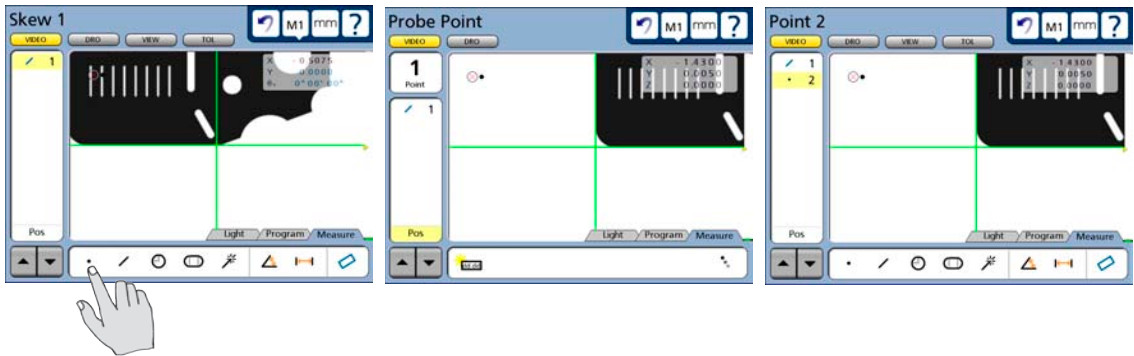

- 2 Select the DRO window, and while the point feature is selected touch the X and Y axis Zero buttons to zero the values and establish a datum zero at the probed point.

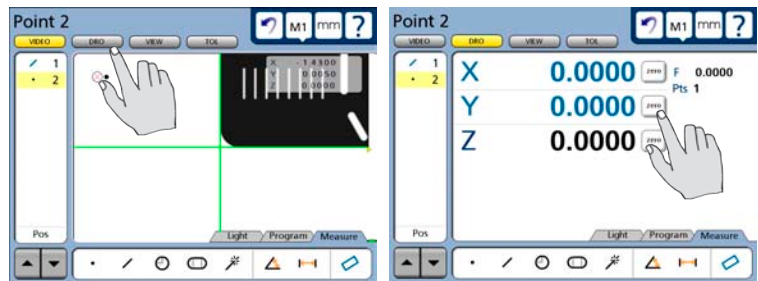

## Constructing a datum zero point

The datum zero point can be constructed from parent features when simply probing the desired point is not desirable.

It would not be possible to provide a single description of this process for all measurement applications that require feature constructions. However, the concept illustrated by the following example and the construction techniques described later in [Chapter 6: Measuring](#) can be used to construct a datum zero point for any measurement application.

In this example, after the part skew is performed, and then a datum zero point is created at the intersection of the X-axis along the bottom of the part (skew axis), and the Y-axis along the left side of the part.

To construct the datum zero point:

- 1 Touch the Measure Line icon. Probe two or more points well distributed along the left side of the part, and then press the Finish button. The line feature will be added to the Features list

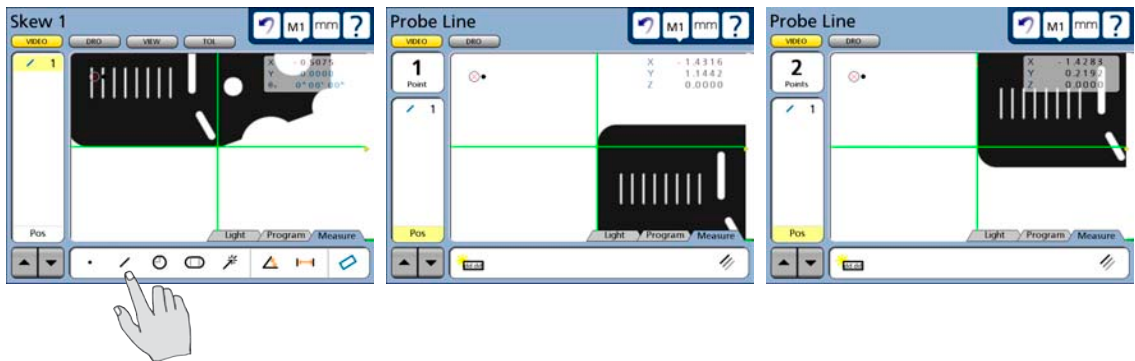

- 3 Touch the Measure Point icon, touch the skew line, touch the line probed on the left side of the part and then press the Enter key. A point constructed at the intersection of the two lines will be added to the Features list.

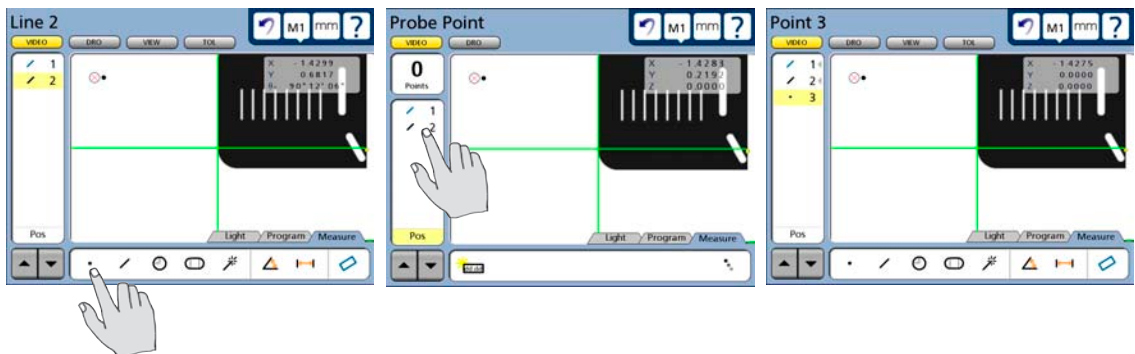

4 Select the DRO window, and while the point feature is selected touch the X and Y axis Zero buttons to zero the values and establish a datum zero at the probed point.

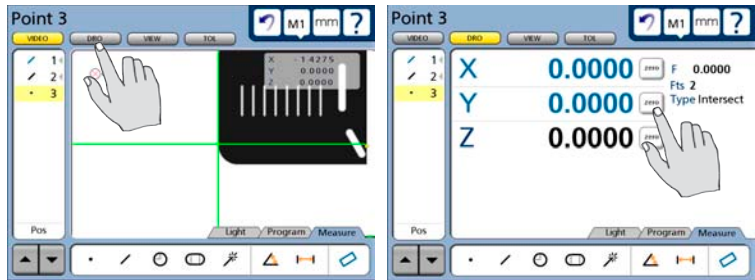
**NOTE**

More information regarding creating datums and constructions is contained in **Chapter 6: Measuring.**

## Measuring features

In this example, the largest of the three holes of the QC Quickie slide will be measured twice illustrating the use of two different probes. First the straight crosshair probe will be used, then the multiple edge probe will be used.

### Measuring a circle with crosshairs

To measure using crosshairs:

- 1 Select the straight crosshair probe.

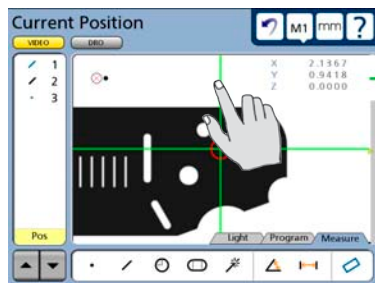

*Touch any part of a probe...*

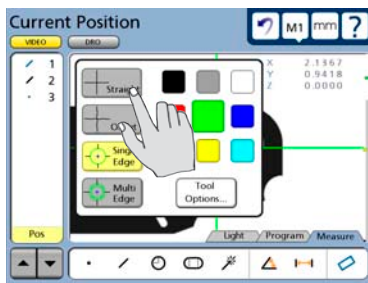

*to display the probe tools...*

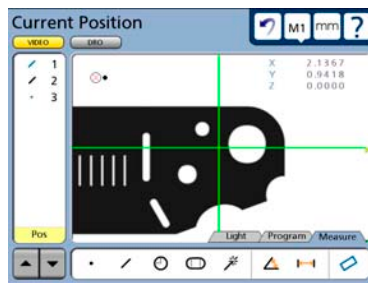

*and select a new probe*

- 2 Touch the measure circle icon and probe a minimum of three points evenly distributed around the perimeter of the circle. Eight points were probed in this example.

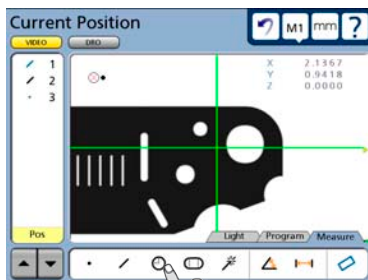

*Select the circle measurement...*

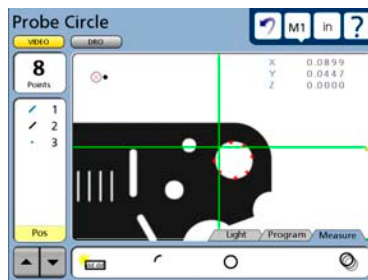

*probe points around the circle and press Finish to complete*

- 3 Press the Finish key to complete the feature measurement and store the feature in the feature list. The feature and probed points can be reviewed in detail by touching the DRO or View button if desired.

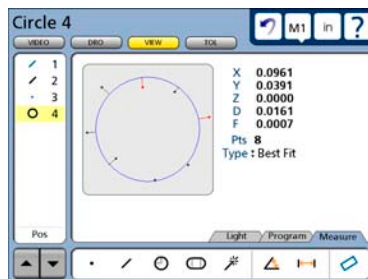
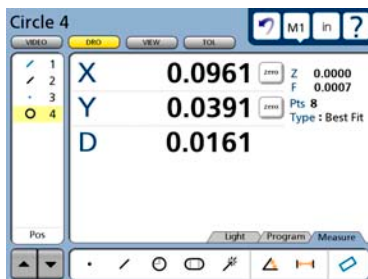

## Measuring a circle with the multiple edge probe

To measure using the multiple edge probe:

- 1 Select the multiple edge probe.

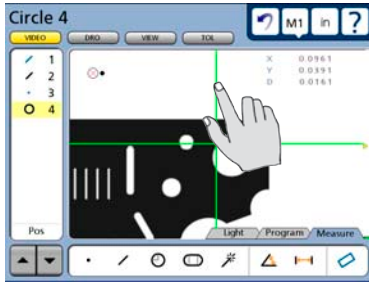

*Touch any part of a probe...*

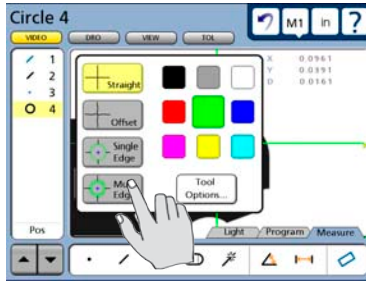

*to display the probe tools...*

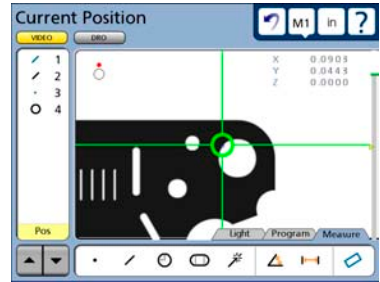

*and select the multi edge probe*

- 2 Touch the probe again to display the probe tools screen, and then touch the Tool Options button to display probing parameters, set the number of circle points to 20 (or any number between 3 and 99), and touch the Finish button.

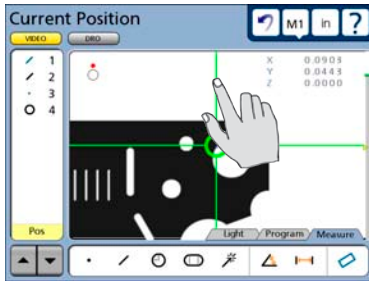

*Touch any part of a probe...*

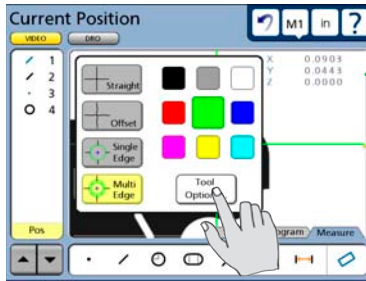

*then touch Tools Options ...*

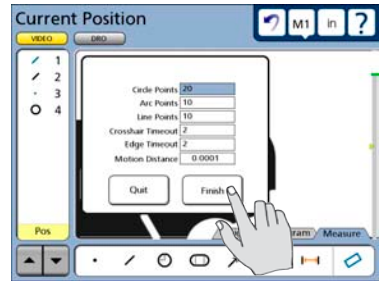

*and set the number of circle points*

- 3 Touch the probe circle icon to begin the measurement.

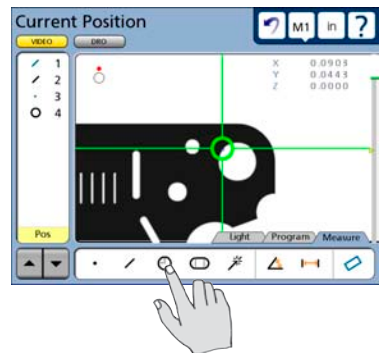

4 Move the stage to position the multiple edge tool into the center of the large circle in the QC Quickie slide and press the Enter key. The measurement will be completed and the circle data will be stored in the feature list.

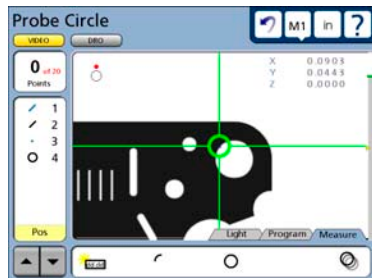

Move the stage to position...

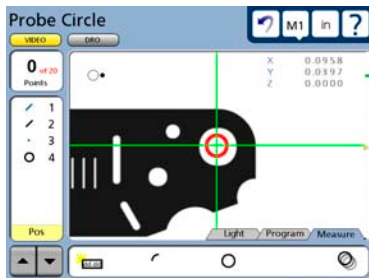

the probe inside the circle...

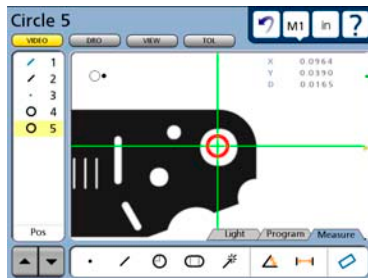

and press Enter to complete

The feature and probed points can be reviewed in detail by touching the DRO or View button if desired.

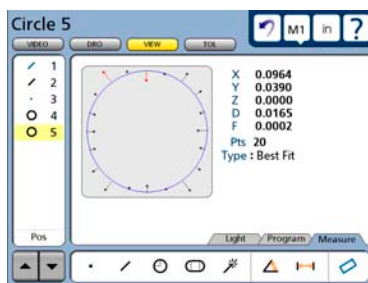
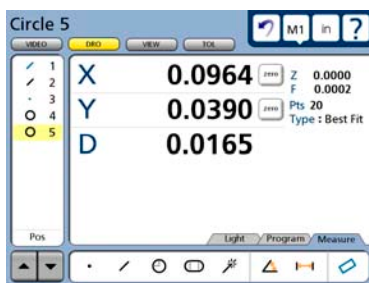

**NOTE**

More information regarding the use of the multiple edge probe is contained in [Chapter 5: Probes](#). More information regarding performing measurements is contained in [Chapter 6: Measuring](#).

## Applying tolerances to feature measurements

In this example, a true position tolerance will be applied to at the last circle measurement. To apply a tolerance:

### Select the feature

Touch the circle feature in the feature list to select it.

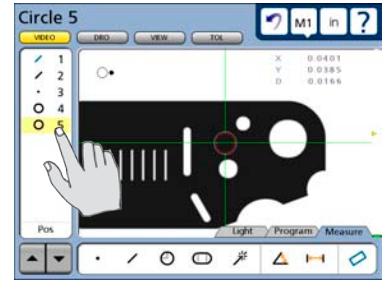

### Display the tolerance screen

Touch the Tol screen button to display the tolerance screen.

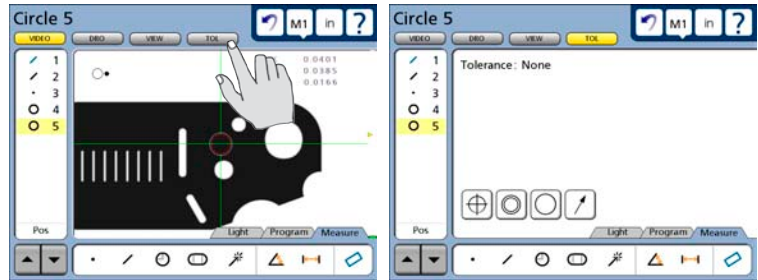

### Select a tolerance type

Touch the desired tolerance type button to select a tolerance type. In this example, the position tolerance type is selected.

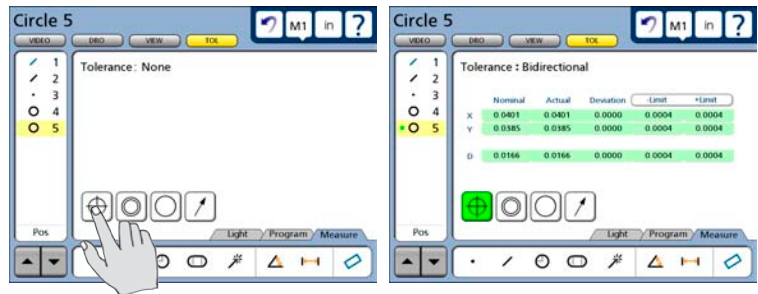

## Select a specific tolerance

Touch the Tolerance menu title and then select the specific tolerance from the drop-down menu. The true position tolerance is selected in this example.

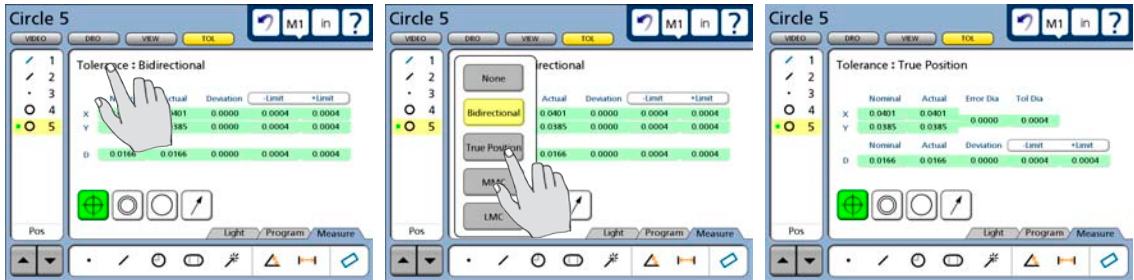

## Enter nominal, limit or tolerance values

In this example, the Nominal and Tol Dia (Tolerance diameter around the nominal position) values are entered by touching the desired data field and entering a new value using the number keys. Error and Deviation values are generated as soon as the Nominal and Tol Dia values are entered.

Tolerance : True Position

	Nominal	Actual	Error Dia	Tol Dia
X	0.0401	0.0401		0.0004
Y	0.0385	0.0385	0.0000	0.0004
D	0.0166	0.0166	0.0000	0.0004

	Nominal	Actual	Deviation	-Limit	+Limit
D	0.0166	0.0166	0.0000	0.0004	0.0004

The Nominal, limit and Tol Dia values are entered...

Tolerance : True Position

	Nominal	Actual	Error Dia	Tol Dia
X	0.0400	0.0401	0.0010	0.0250
Y	0.0390	0.0385		
D	0.0160	0.0166	0.0006	0.0010

	Nominal	Actual	Deviation	-Limit	+Limit
D	0.0160	0.0166	0.0006	0.0010	0.0010

resulting in new error and deviation values

Pass/fail results are indicated by green and red colors in the tolerance screen and in the feature list. Pass is indicated by green, fail is indicated by red in the tolerance screen. Any tolerance failure will be indicated by a red mark next to the feature in the feature list. A green mark will be displayed in the feature list when all tolerance tests pass.



**NOTE**

More information regarding tolerances is contained in **Chapter 7: Tolerancing.**

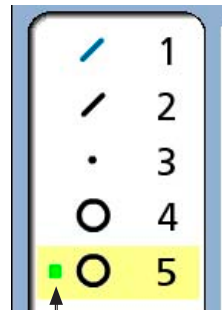

Pass indication is a green square



## Printing a report

To print a report of the current position (Display), the feature list (Report) or tolerances (Tol Report):

- 1 Verify that the QC-300 is attached to a USB printer as described in [Chapter 9: Communication](#).
- 2 Verify that the report content and printer formatting are specified correctly in the Print setup screen described in [Chapter 9: Communication](#) and [Chapter 10: Setup](#).
- 3 Press the Print key while displaying the Current Position in the Video or DRO screen.

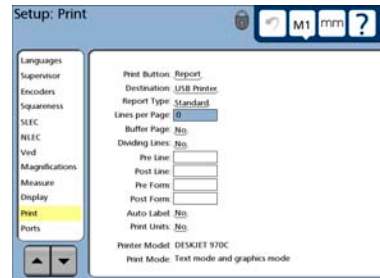

### NOTE

More information regarding reports of feature measurement data and QC-300 system settings are contained in [Chapter 9: Communication](#).

## Stopping the program recording

Touch the Program tab to display the programming tools, and then touch the Stop icon to stop recording the program. The program title will be shown and program steps will be displayed in the feature list.

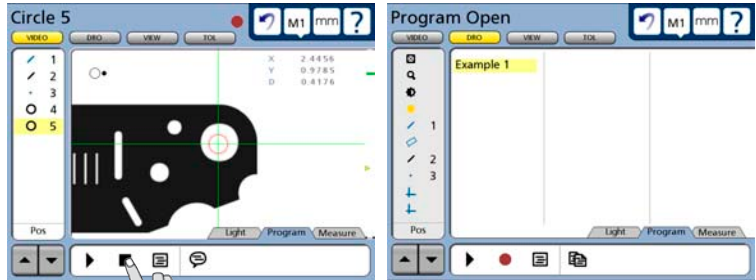

The program is now saved and can be edited or run on new parts. Touch the Measure tab to leave the record mode and return to the measure mode of operation.

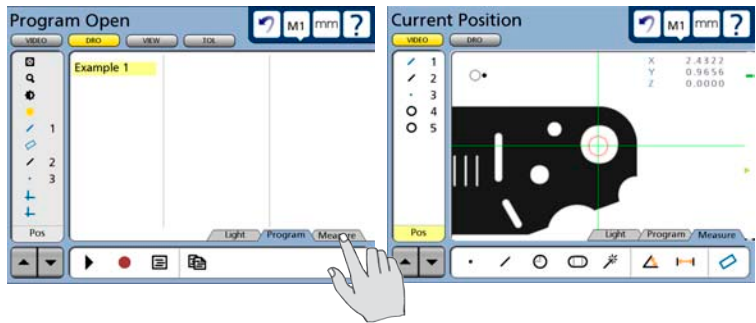

## Running the program

To run a program, Touch the Program tab to display the program screen and then touch a program title to select the desired program.

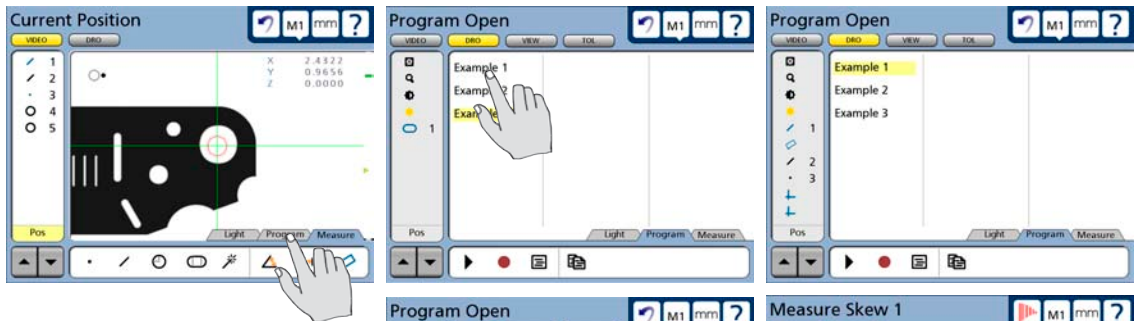

Touch the Run icon to run the selected program.

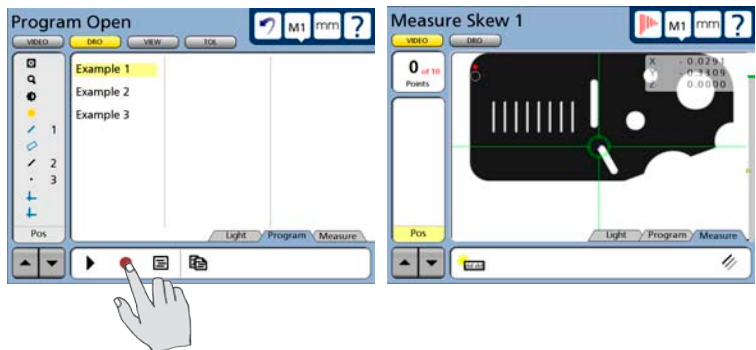

# Chapter 5: Probes

Measurements are conducted using manual crosshairs, video crosshairs or video edge detection on manually controlled systems. Part features can be probed manually by the user or automatically under program control.

Video probe setup and calibration is described in [Chapter 10: Setup](#). The measurement, construction and creation of features is explained in [Chapter 6: Measuring](#).

Preparing to use video probes .....	40
System and part condition.....	40
Selecting video magnification.....	40
Adjusting light control .....	40
Adjusting video image contrast and brightness .....	43
Using video probes.....	46
Selecting a probe .....	46
Selecting a probe color.....	47
Specifying probe data collection parameters .....	48
Crosshair probe data collection parameters .....	49
Edge probe data collection parameters .....	50
Collecting feature data .....	51
The auto-enter function.....	51
Crosshair probes .....	52
Manual probing (crosshairs).....	52
Automatic probing (crosshairs) .....	53
Single edge probe .....	54
Manual probing (single edge).....	54
Automatic probing (single edge) .....	55
Multiple edge probe.....	56
Probe seeding.....	56
Probing a line.....	57
Probing a circle.....	58
Probing an arc.....	60
Seeding to avoid erroneous data.....	61
Recovering from data errors.....	62

## Preparing to use video probes

The accuracy and repeatability of video probing depends on the condition of the system, the condition of the part, video magnification, part lighting and optical focus.

### System and part condition

The system is presumed to be well-maintained which implies a clean stage and optical system, free of scratches and other damage. The part to be measured is also presumed to be clean and undamaged.

### Selecting video magnification

Select a different video magnification by adjusting the camera optics, touching the magnification button and then touching the desired magnification in the drop-down menu. The magnifications that appear in the drop-down menu are added and calibrated in the Magnifications setup screen by supervisors, distributors and OEMs.

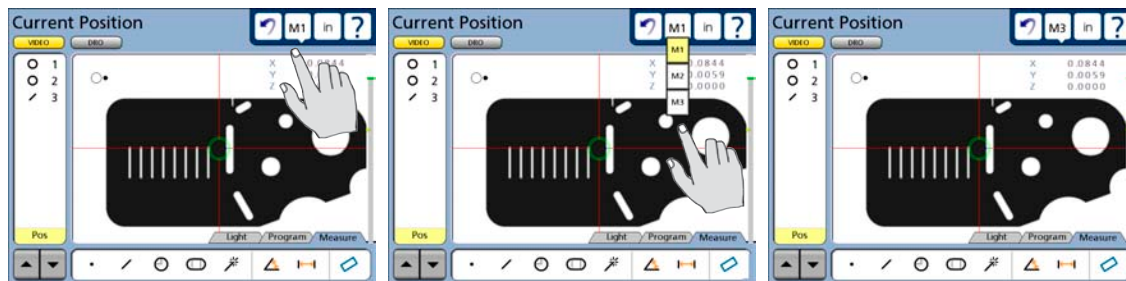

### Adjusting light control

The video back light, surface light and ring lights are adjusted to optimize part illumination by selecting the desired light sources and operating the light slider controls. Light sources can be different in each system and can include:

- Back light      Single light source directly under the part that provides back lighting
- Top light        Single light source directly over the part that provides surface lighting, sometimes through the lens
- Ring lights      Four light sources are enabled or disabled individually and distributed in a ring around the camera axis. The light intensities of all enabled ring lights are controlled simultaneously as a single group. The ring lighting is often provided by one source.

To adjust the light sources:

- 1 Touch the Light/Image tab at the bottom of the screen repeatedly to display the Light controls.

When the Light tab is shown in the background...

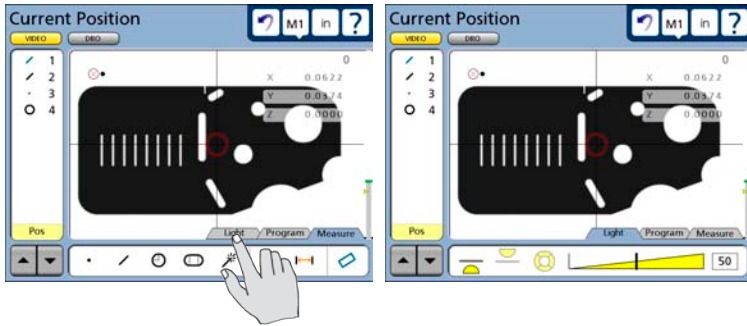

Touch the Light tab...

to display the light controls

When the Image tab is shown in the background...

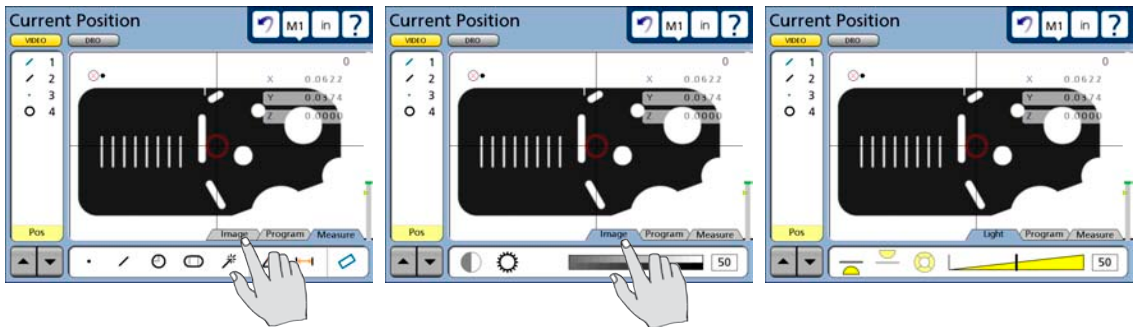

Touch the Image tab...

twice...

to display the light controls

2 Touch the desired light source to select it for adjustment.

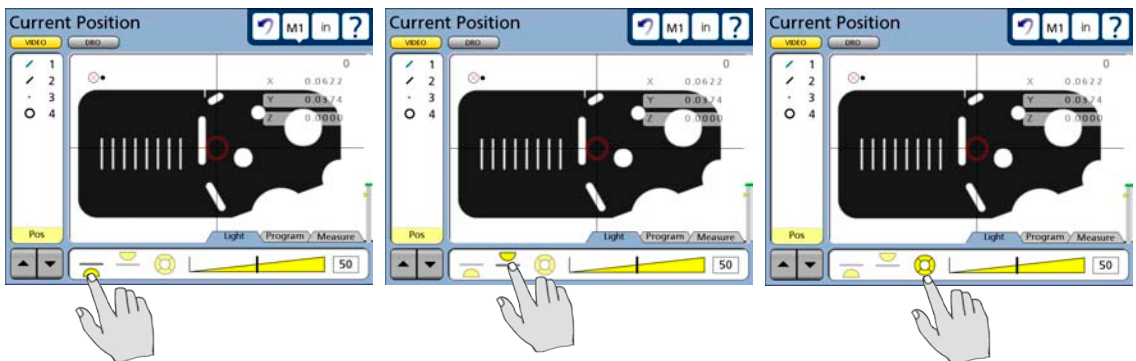

Select the back light...

Select the top light...

or ring lights

When ring lights are selected, touch the ring light icon again to display individual ring light segments.

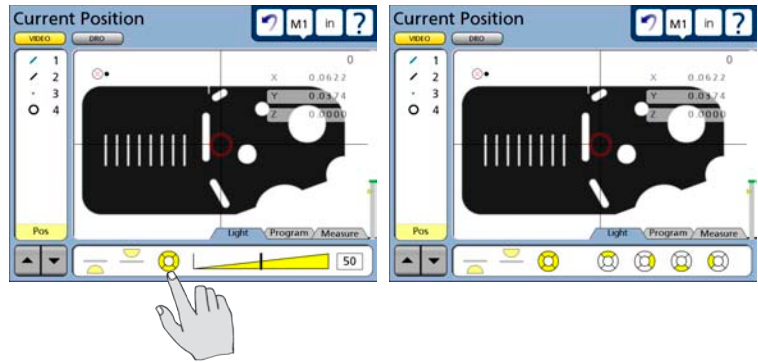

*Touch the ring light icon again...*

*to show individual segments*

Any of the individual ring light segments can be turned on or off by touching them.

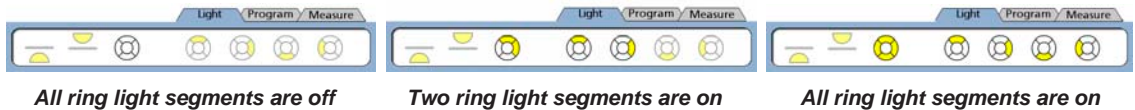

*All ring light segments are off*

*Two ring light segments are on*

*All ring light segments are on*

Touch the ring light icon again to display the adjustment slider.

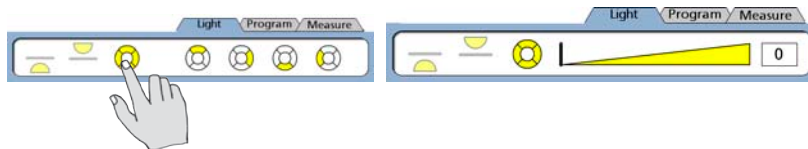

3 Touch and drag an adjustment slider to adjust the illumination of any light source. All light sources are adjusted in this manner using its own slider.



*Touch and drag the slider...*

*to make light adjustments*

## Adjusting video image contrast and brightness

The contrast and brightness of the video camera image displayed in the video window are adjusted to optimize edge detection by selecting the Image tab and using the image contrast and brightness sliders.



**NOTE**

The video image contrast and brightness adjustments are different than the overall screen contrast and brightness adjustments found in the Miscellaneous setup screen.

To adjust the video image contrast and brightness:

- 1 Touch the Light/Image tab at the bottom of the screen repeatedly if necessary to display the Image controls.

*When the Image tab is shown in the background...*

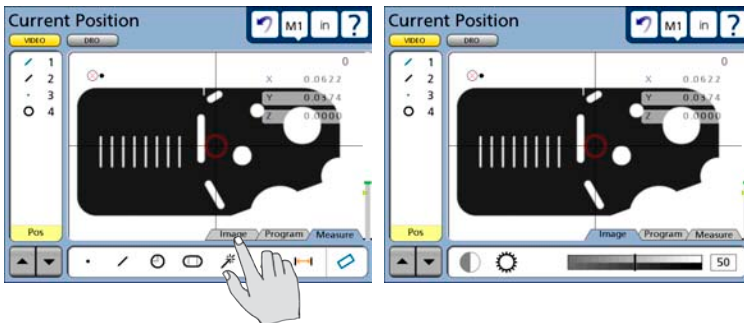

*Touch the Image tab...*

*to display the Image controls*

*When the Light tab is shown in the background...*

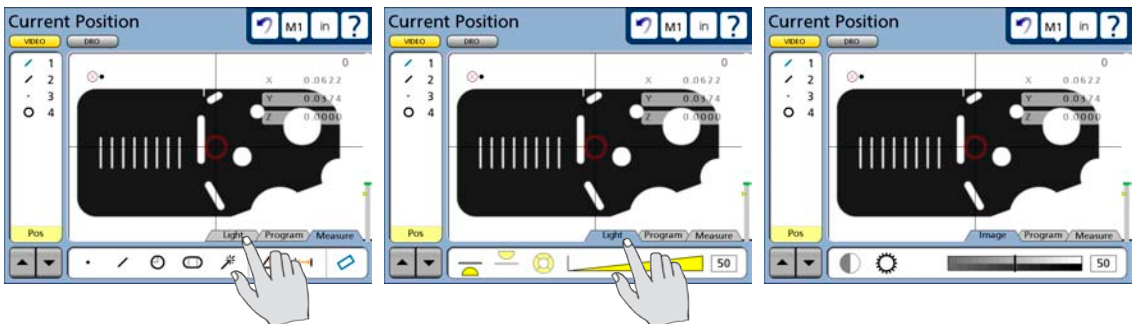

*Touch the Light tab...*

*twice...*

*to display the Image controls*

- 2 Touch the contrast icon and then touch and drag the contrast slider to adjust video contrast.

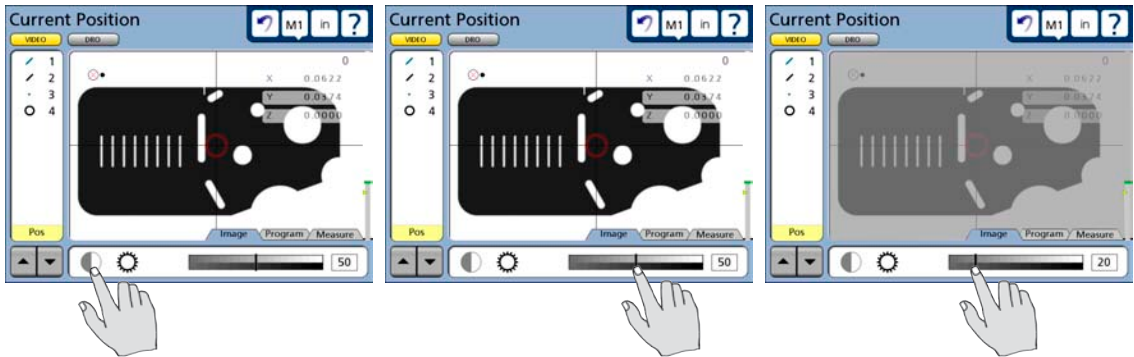

*Touch the Contrast icon...*

*then touch and drag the slider...*

*to adjust contrast*

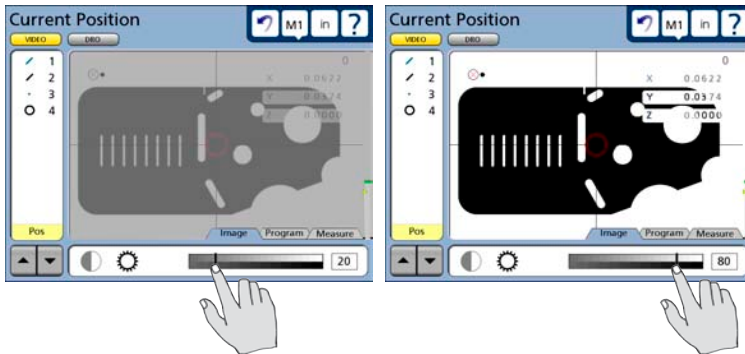

*Drag left to decrease contrast...*

*and right to increase contrast*

- 3 Touch the Brightness icon and then touch and drag the brightness slider to adjust video brightness.

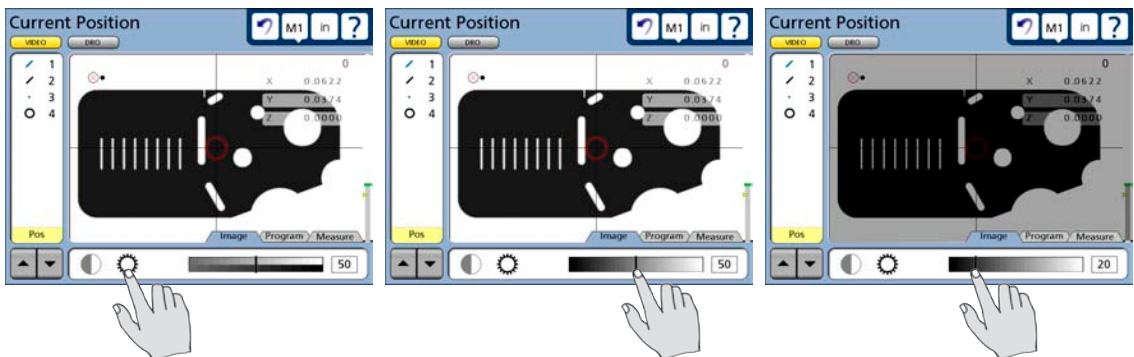

*Touch the Brightness icon...*

*then touch and drag the slider...*

*to adjust brightness*



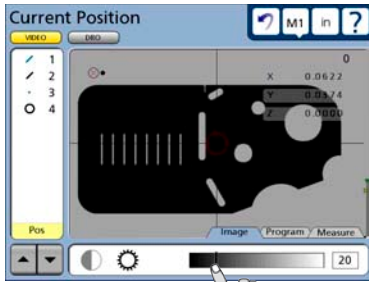

Drag left to decrease brightness...

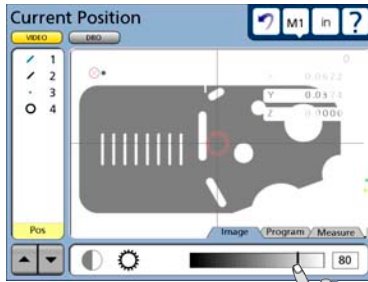

and right to increase brightness



**NOTE**

Contrast and brightness can be fine-adjusted by one unit of contrast or brightness by touching the slider bar on either side of the slider control.

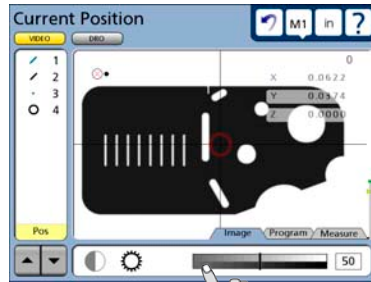

Touch left to adjust down 1 unit

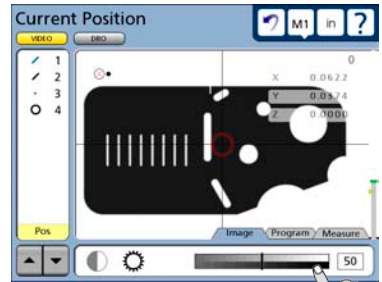

Touch right to adjust up 1 unit

## Using video probes

Four video probes are available for creating reference levels, skews and datums and for measuring regular geometric features including points, lines, arcs, circles, slots, rectangles, distances and angles. Probes include:

- **Crosshair** Standard crosshair of two lines crossed at 90 degrees. Single points can be acquired manually or automatically.
- **Offset crosshair** Crosshair of two lines with a regular pattern 3 pixel square wave offsets, crossed at 90 degrees. Single points can be acquired manually or automatically.
- **Single edge** Standard crosshair with a small circle at the center for positioning the edge detector. Single points can be acquired manually or automatically.
- **Multiple edge** Standard crosshair with 2 small concentric circles at the center for positioning the edge detector. Multiple points can be acquired for certain feature types automatically.

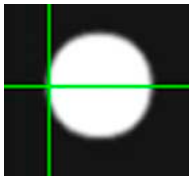

*Crosshair*



*Offset crosshair*

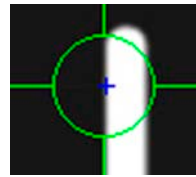

*Single edge*

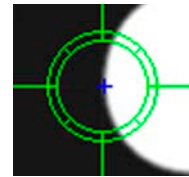

*Multiple edge*

Firing a video probe generates one or more orthogonal scan lines, which acquire points as the scans cross an edge bounded by light and dark areas of the screen image. The use of these four probes is very straightforward, as shown below.

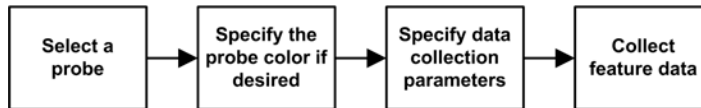

## Selecting a probe

To select a new probe:

- 1 Select a new probe type by touching any part of the current probe on the Video window. The four probe choices will be shown on the probe pop-up screen.

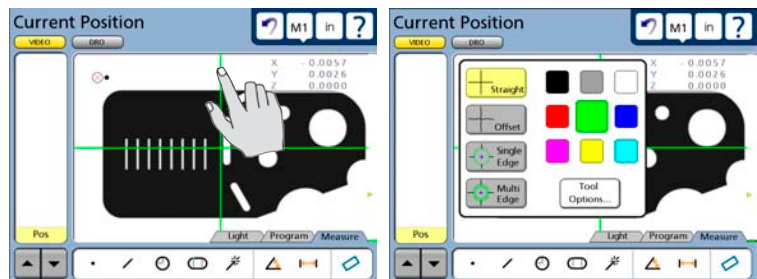

2 Touch the desired probe type button. The probe pop-up screen will close and the new probe will be displayed. In this example the Multi-edge probe is selected.

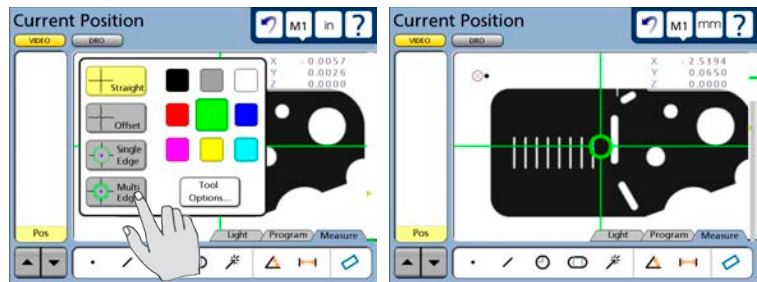

### Selecting a probe color

The probe color can be selected at any time from one of nine colors that are shown on the probe pop-up screen. To select the probe color:

1 Touch any part of the current probe on the Video window. The nine color choices will be shown on the probe pop-up screen.

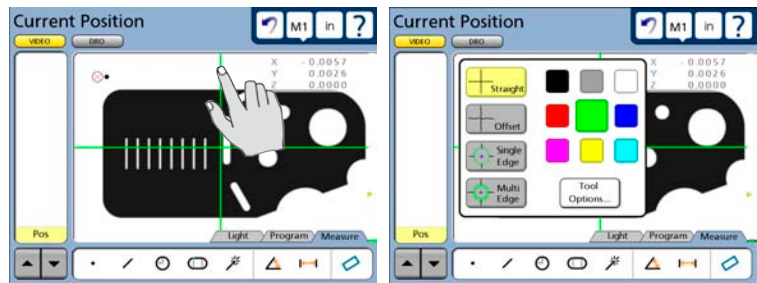

2 Touch the desired probe color button. The probe pop-up screen will close and the new probe color will be displayed. In this example the red probe color is selected.

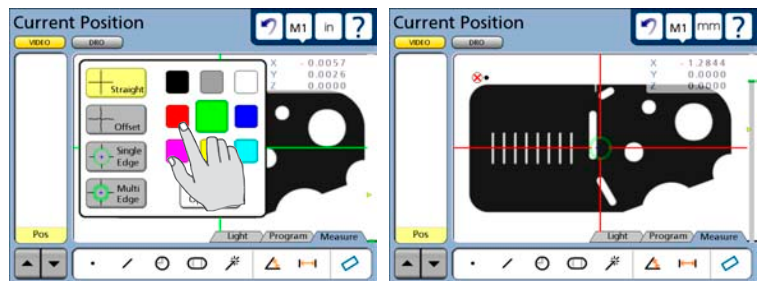

#### NOTE

The color of the single edge and multiple edge probe circles (at the center of the probes) cannot be changed because color is used to indicate whether or not an edge has been detected. Red circles indicate that no edge has been detected. Green circles indicate that an edge has been detected. The color of the remaining straight line portions of edge probes can be changed.

## Specifying probe data collection parameters

Video probe data collection parameters are specified in the Tool Options portion of the probe pop-up screen and include:

- The number of points to be collected for line, circle and arc measurement by the multiple edge probe
- Delays after the stage motion stops for auto-point entry using crosshair and edge probes
- The minimum stage motion required to restart the crosshair timeout delay for auto-point entry using crosshair probes

Usually, the data collection parameters are specified for a probe and remain unchanged until significant changes are encountered in the part probing process, or the system hardware is changed.

To specify probe data collection parameters:

1 Touch any part of the current probe on the Video window. The probe pop-up screen will be displayed.

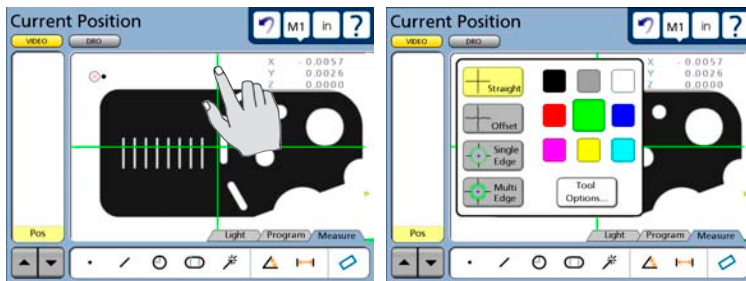

2 Touch the Tool Option button. The probe data collection parameter setup fields will be displayed.

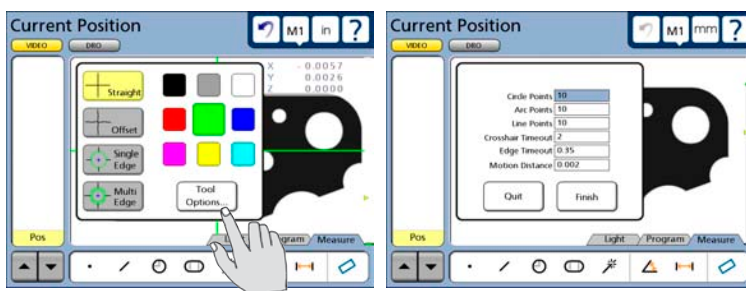

Only a few data collection parameters are required, and they are different for crosshair and edge probes.

### Crosshair probe data collection parameters

Data collection parameters for crosshair probes include:

- Crosshair timeout delay
- Motion distance

#### Crosshair timeout delay

When the auto-enter function is enabled during feature measurement on the LCD Video screen, a point is collected by the system each time the stage is moved to position the part under the crosshair. This automatic point entry is delayed until the stage has been motionless for a short time to ensure that the crosshair is located where the user intended. This delay is the Crosshair Timeout. This parameter is identical for the straight and offset crosshair probes. The default value will provide adequate delay for most applications, but can be increased to accommodate more relaxed probing.

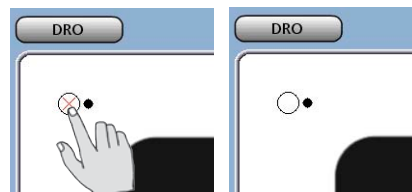

*The auto-enter function is enabled on the LCD video screen*

To specify Crosshair Timeout, touch the Crosshair Timeout data field and enter the desired delay in seconds using the number keys.

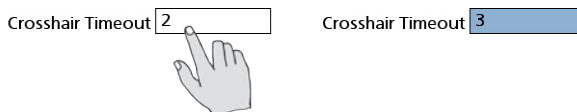

#### Motion distance

As described above, when the auto-enter function is enabled, a point is collected by the system each time the stage is moved to position the part under the crosshair at a new location. This automatic point entry is delayed until the stage has been motionless for a short time to ensure that the crosshair is located where the user intended. This delay is restarted if the stage moves again during the timeout interval to facilitate final fine adjustments of stage position.

To specify the minimum stage movement required to restart the crosshair timeout delay, touch the Motion Distance data field and enter the desired stage motion in the current unit of measure (millimeters or inches).

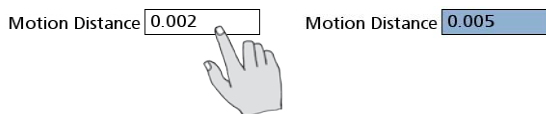

### Edge probe data collection parameters

Data collection parameters for edge probes include:

- The number of points to be collected for lines, circles and arcs by the multiple edge probe
- Edge timeout delay

#### Number of points probed for a line, circle and arc

When the multiple edge probe is used, the probe is seeded with a small number of points to define the feature type, and then the remaining points are collected automatically by the system. Up to 99 points can be collected for line, circle and arc features.

To specify the number of points collected for line, circle or arc features, touch the Line, Circle or Arc Point data field and enter the desired number of points using the number keys.

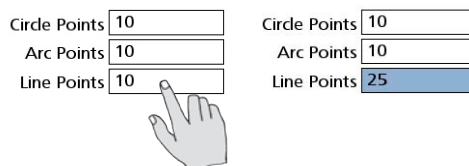

#### Edge timeout delay

When the auto-enter function is enabled for feature measurement on the LCD Video screen, a point is collected by the system each time the stage is moved to position the part under the edge probe. This automatic point entry is delayed until the stage has been motionless for a short time to ensure that the edge probe is located where the user intended. This delay is the Edge Timeout. This parameter is identical for the single and multiple edge probes. The default value will provide adequate delay for most applications, but can be increased to accommodate more relaxed probing.

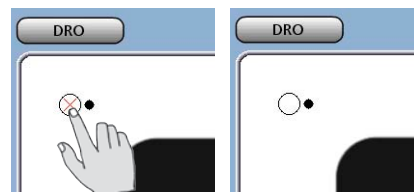

**The auto-enter function is enabled on the LCD video screen**

To specify Edge Timeout, touch the Edge Timeout data field and enter the desired delay in seconds using the number keys.

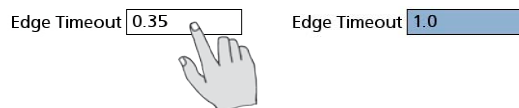

**Collecting feature data**

Feature data can be collected manually by positioning a probe over a part feature and pressing the Enter key, or collected automatically by enabling the auto-enter function and using the multiple edge probe. Manual probing with crosshairs is useful when part edges are indistinct and feature edge contrast is poor. Automatic probing can acquire many points simultaneously and increases productivity when feature edge boundaries are clear and automatic point entry is possible.

**The auto-enter function**

The auto-enter function is toggled on or off by touching the auto-enter icon in the upper-left corner of the video screen.

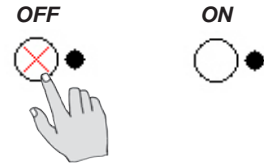

*The auto-enter function is toggled on*

When the auto-enter function is toggled on, the crosshair and edge probes will acquire a point automatically after the stage motion stops to position the probe over a feature or edge. Refer to the descriptions of crosshair and edge timeout delay on the previous two pages for more details regarding point acquisition timing.

When the auto-enter function begins to acquire a point, the icon dot rotates clockwise around the icon to indicate the passage of the crosshair or edge timeout delay period. This delay is restarted if the stage is moved an amount equal to or greater than the Motion Distance value described earlier.



## Crosshair probes

The crosshair probes consist of two lines crossed at 90 degrees in the video window. Probing is identical for straight and offset crosshairs. Single points can be acquired manually or automatically.

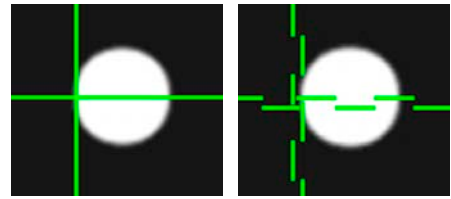

Straight crosshairs

Offset crosshairs

### Manual probing (crosshairs)

Disable auto-enter for manual probing. To probe part features manually:



1 Select the feature to be measured. The Circle measurement is selected in this example.

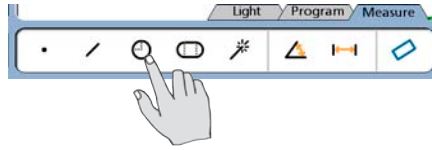

2 Position the probe over the desired feature location.

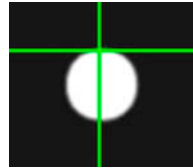

3 Press the Enter key to acquire a point.



4 Repeat steps 2 and 3 until all the required points have been probed.

5 Press the Finish key to complete the feature measurement and store the feature in the feature list. The feature and probed points can be reviewed in detail by touching the View button if desired.

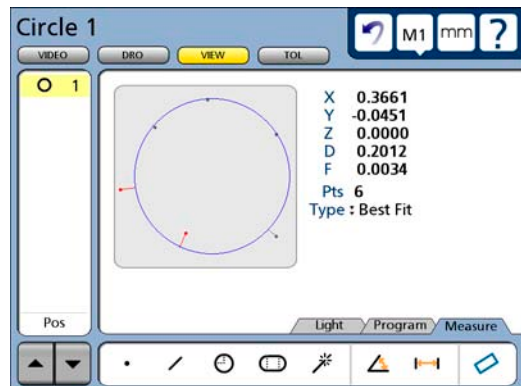
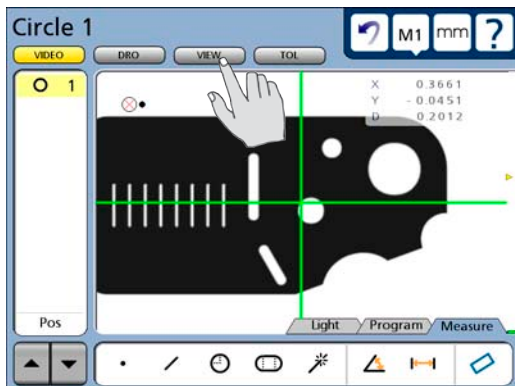
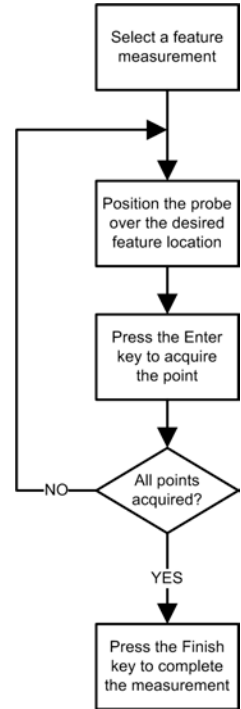



**Automatic probing (crosshairs)**

The process of probing automatically with crosshairs is identical to probing manually with crosshairs except that the user does not press the Enter key to enter points.

Enable auto-enter for manual probing.  
To probe part features automatically:



1 Select the feature to be measured. The Circle measurement is selected in this example.

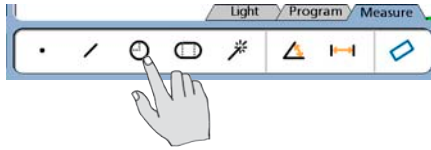

2 Position the probe over the desired feature location.

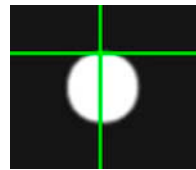

3 The point will be acquired after the crosshair timeout delay, unless the stage is moved before the delay is complete. If the stage is moved, the delay will be reinitiated.



4 Repeat steps 2 and 3 until all the required points have been probed.

5 Press the Finish key to complete the feature measurement and store the feature in the feature list. The feature and probed points can be reviewed in detail by touching the View button if desired.

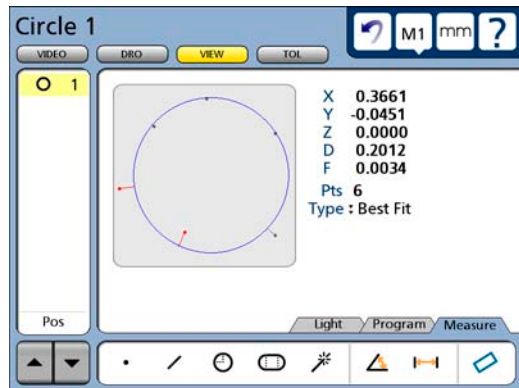
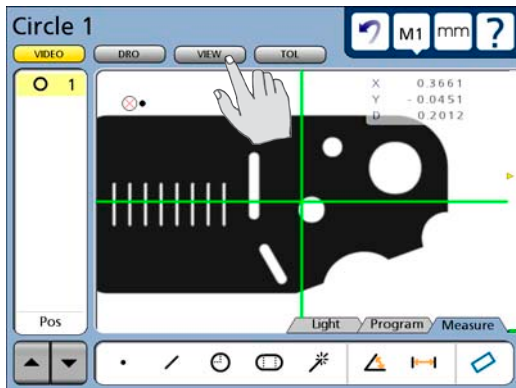
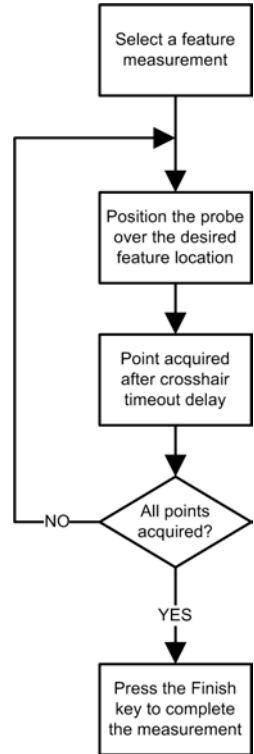

## Single edge probe

The single edge probe consists of a standard crosshair with a small circle at the center for positioning the edge detector. Single points can be acquired manually or automatically.

### Manual probing (single edge)

Disable auto-enter for manual probing. To probe part features manually:

- 1 Select the feature to be measured. The Circle measurement is selected in this example.

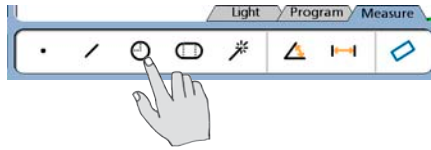

- 2 Position the probe over the desired feature edge. A blue cross with indicate the point that will be acquired. Reposition the probe if necessary to acquire the desired point.

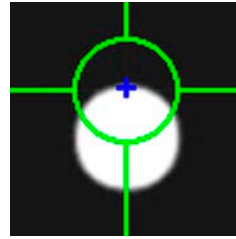

Single edge probe

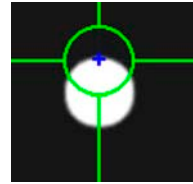

- 3 Press the Enter key to acquire a point.

- 4 Repeat steps 2 and 3 until all the required points have been probed.

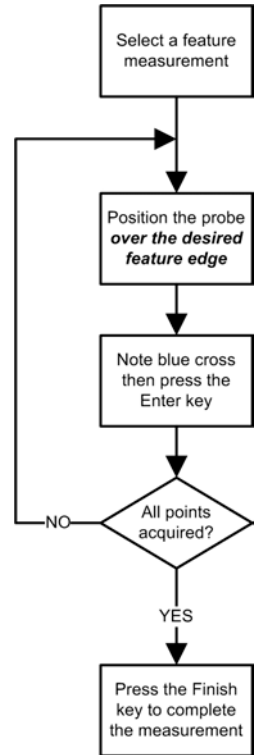
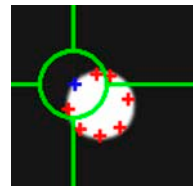

- 5 Press the Finish key to complete the feature measurement and store the feature in the feature list. The feature and probed points can be reviewed in detail by touching the View button if desired.

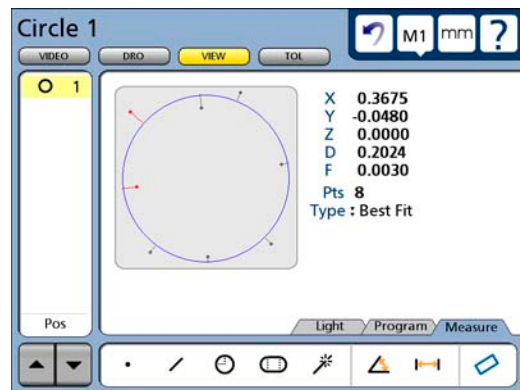
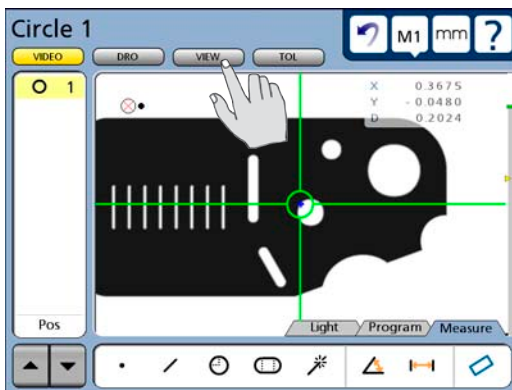

**Automatic probing (single edge)**

The process of probing automatically with the single edge probe is identical to probing manually with the single edge probe except that the user does not press the Enter key to enter points.

Enable auto-enter for manual probing.  
To probe part features automatically:



1 Select the feature to be measured. The Circle measurement is selected in this example.

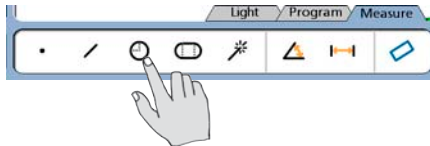

2 Position the probe over the desired feature edge. A blue cross with indicate the point that will be acquired. Reposition the probe if necessary to acquire the desired point.



3 The point will be acquired after the edge timeout delay.

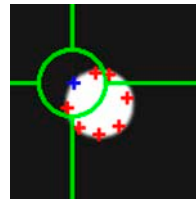

4 Repeat steps 2 and 3 until all the required points have been probed.

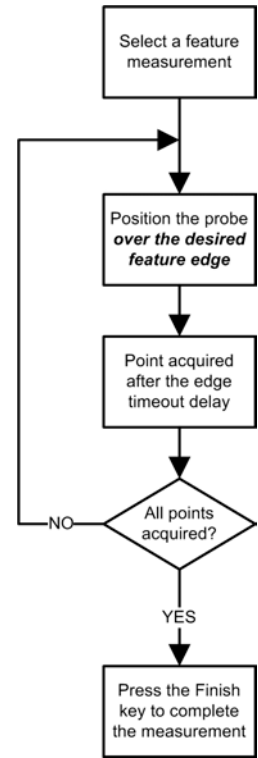

5 Press the Finish key to complete the feature measurement and store the feature in the feature list. The feature and probed points can be reviewed in detail by touching the View button if desired.

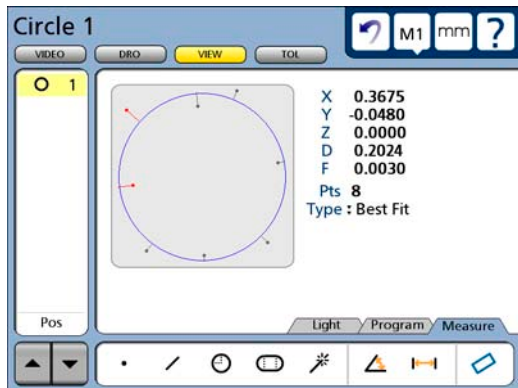
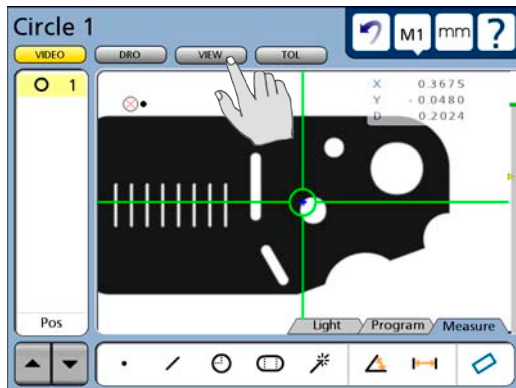

## Multiple edge probe

The multiple edge probe consists of a standard crosshair with two small concentric circles at the center for positioning the edge detector. Points will be probed manually for some features as they are when the single edge probe is used, and automatically for line, circle and arc features when the probe is seeded.

### Probe seeding

When points are probed automatically as diagrammed at the right, the probe must first be seeded by probing the minimum number of points required for a geometric definition of the feature type. Only lines, circles and arcs can be probed automatically.

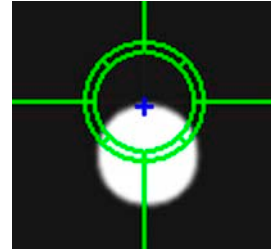

- Line Points probed automatically after seeding with 2 points
- Circle Points probed automatically after seeding with 3 points
- Arc Points probed automatically after seeding with 3 points
- Point Points probed manually - identical to single edge probe
- Distance Points probed manually - identical to single edge probe
- Angle Points probed manually - identical to single edge probe
- Slot Points probed manually - identical to single edge probe
- Rectangle Points probed manually - identical to single edge probe

When probing lines, circles and arcs, the multiple edge probe must be seeded to provide the system with a general description of the feature location. The location of seed points is important. The order of seed points is important for arcs.

- Line Seed by probing 2 points at the extreme ends of the line.
- Circle Seed by probing 3 points evenly distributed around the perimeter of the circle.
- Arc Seed by probing 3 evenly distributed points in sequence from the beginning to end of the arc.

The seed points can be entered manually by pressing the Enter key, or automatically using the auto-enter function.



**Auto-enter  
disabled**



**Auto-enter  
enabled**

When all the required points have been seeded, a green arrow and red circle are displayed. Move the stage to place the green arrow into the red circle to initiate automatic probing of the remaining points and complete the measurement.



*When the probe is seeded...*



*move the stage to place...*



*the arrow in the circle*

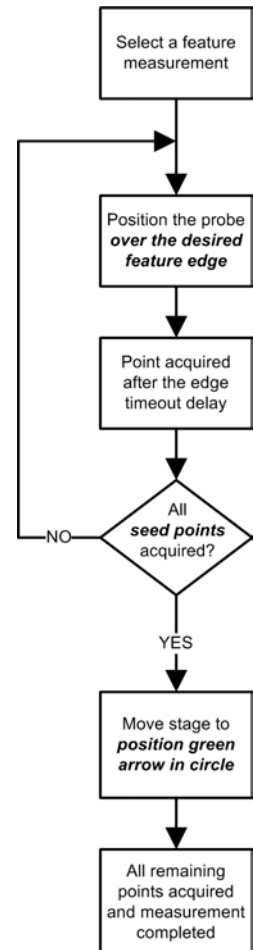

**Probing a line**

The same basic technique is used to probe a line whether the line is completely within or outside the field of view. To probe a line using the multiple edge probe:

1 Select the Line feature measurement, and then select the multiple edge probe.

2 Seed the multiple edge probe at the two extreme ends of the line. The green arrow and red circle will be presented.

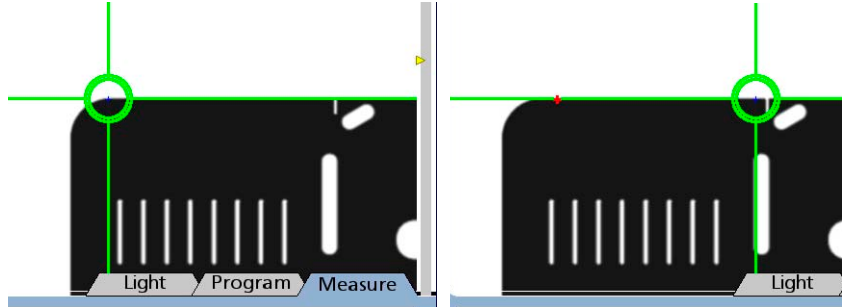

*Seed the multiple edge probe at the two extreme ends of the line*

3 Move the stage to place the green arrow inside the red circle. The remaining line points will be probed at roughly regular intervals along the line, the measurement will be completed and the feature data will be stored in the feature list.

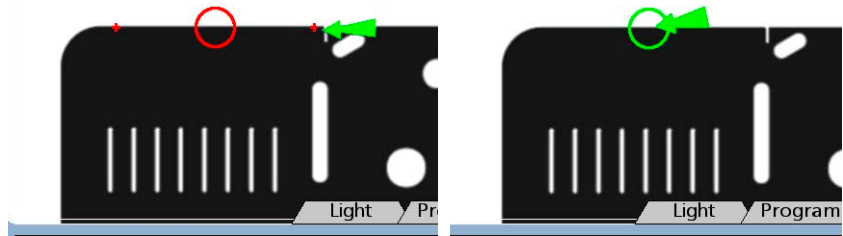

*Move the stage to place the arrow in the circle*

4 The feature and probed points can be reviewed in detail by touching the View button if desired.

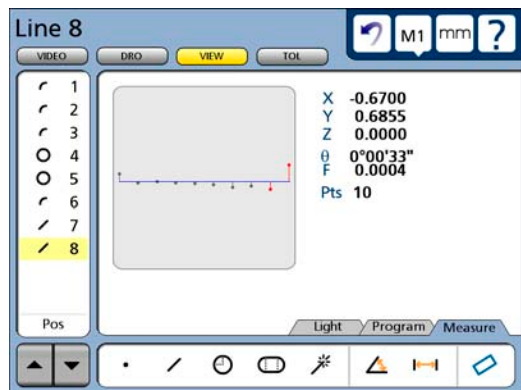
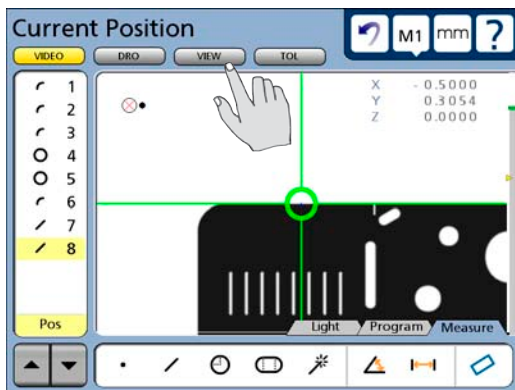

### Probing a circle

Two techniques can be used to probe a circle using the Multiple edge probe. The first technique is that described earlier for probing lines and arcs and can be used to probe a circle whether the circle is completely within or outside the field of view. To probe a circle using the first technique with the multiple edge probe:

1 Select the Circle feature measurement, and then select the multiple edge probe.

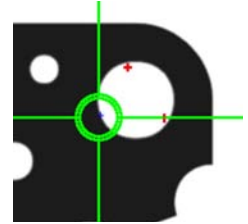
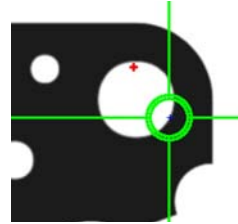
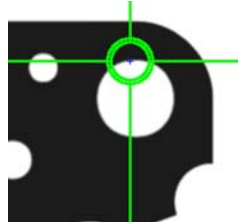

2 Seed the multiple edge probe at 3 points evenly distributed around the perimeter of the circle.

*Seed the multiple edge probe at 3 points evenly distributed around the circle*

3 Move the stage to place the green arrow inside the red circle. The remaining circle points will be probed at roughly regular intervals around the perimeter of the circle, the measurement will be completed and the feature data will be stored in the feature list.

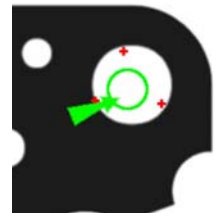
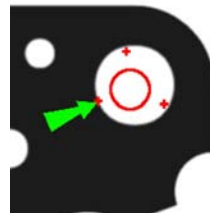

*Move the stage to place the arrow in the circle*

4 The feature and probed points can be reviewed in detail by touching the View button if desired.

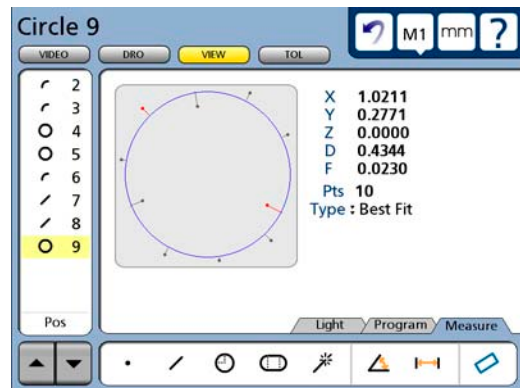
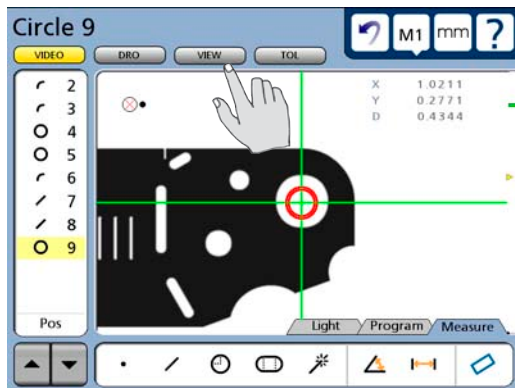

The second technique can only probe a circle located within the field of view that is large enough to enclose the center of the Multiple edge probe, but the technique is extremely simple and productive. To probe a circle using the second technique with the multiple edge probe:

- 1 Select the Circle feature measurement, and then select the multiple edge probe. Select a circle that will completely enclose the center of the Multiple edge probe.
- 2 Move the stage to place the center of the Multiple edge probe inside the circle. The center of the Multiple edge probe should be red to indicate that no edge is detected.

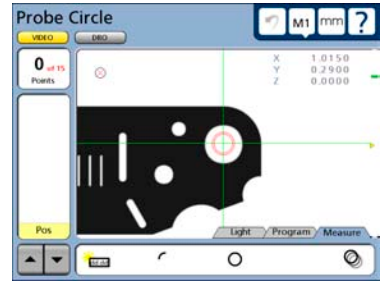

- 3 Press the Enter key. All the circle points will be probed at roughly regular intervals around the perimeter of the circle, the measurement will be completed and the feature data will be stored in the feature list.

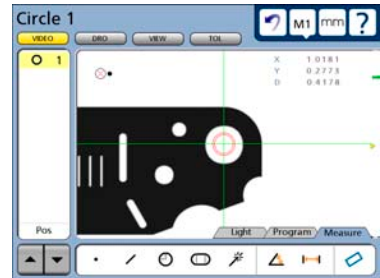

- 4 The feature and probed points can be reviewed in detail by touching the View button if desired.

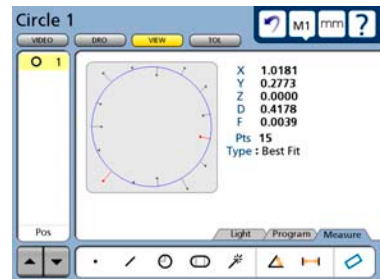

**Probing an arc**

The same basic technique is used to probe an arc whether the arc is completely within or outside the field of view. To probe an arc using the multiple edge probe:

- 1 Select the Arc feature measurement, and then select the multiple edge probe.

- 2 Seed the multiple edge probe at 3 points in sequence from the beginning to the end of the arc.

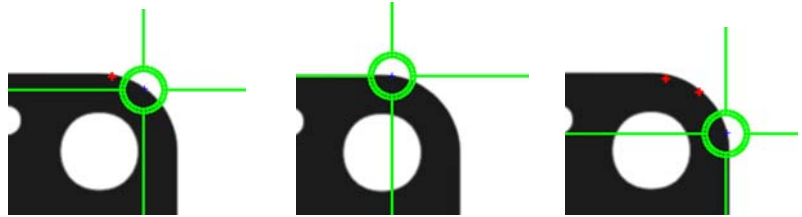

*Seed the multiple edge probe at 3 points in sequence from the beginning to the end of the arc*

- 3 Move the stage to place the green arrow inside the red circle. The remaining line points will be probed at roughly regular intervals along the length of the arc, the measurement will be completed and the feature data will be stored in the feature list.

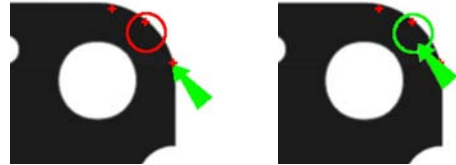

*Move the stage to place the arrow in the circle*

- 4 The feature and probed points can be reviewed in detail by touching the View button if desired.

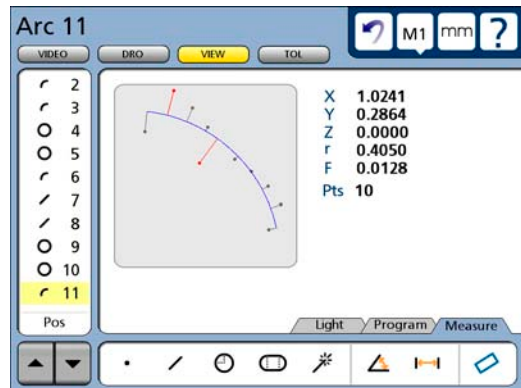
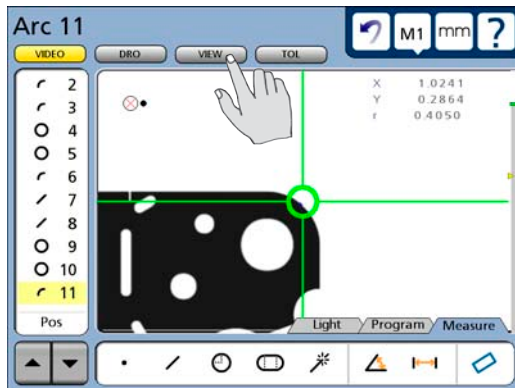



**Seeding to avoid erroneous data**

The multiple edge probe can be seeded manually using the single edge probe to avoid collecting data over keyways, protrusions and other feature anomalies. This is accomplished by:

- 1 Seeding points very close to, and enclosing the area of anomaly using the single edge probe
- 2 Switching to the multiple edge probe to complete the measurement by probing the remainder of specified points automatically

Normally, the multiple edge probe attempts to collect the specified number of points from an even distribution of probed points along the feature edge, which includes the seed points.

As shown in the example below, when a line without anomalies is probed, the multiple edge probe is seeded with the two endpoints, and then automatically probes the remainder of the specified points at locations distributed evenly between the endpoints.

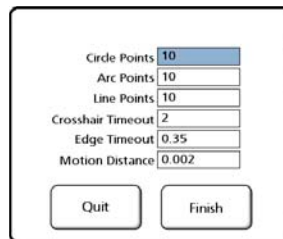

**10 Points are specified for a line**

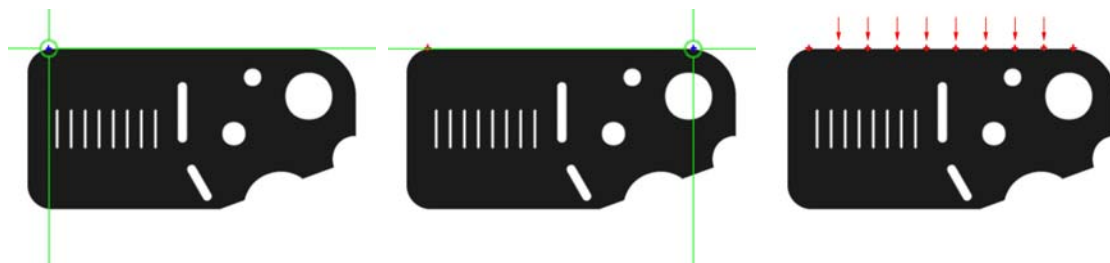

**The multiple edge probe is seeded with the endpoints of the line, and evenly distributes the remaining points**

This process works well when the feature probed includes few or no edge anomalies. However, discontinuous or indistinct edges can lead to data errors if no preventive action is taken.

Since a combination of seeded locations and system-generated locations are used to distribute and probe points, tightly enclosing any edge anomaly between two seeded points greatly reduces the possibility that the multiple edge probe will probe the anomaly.

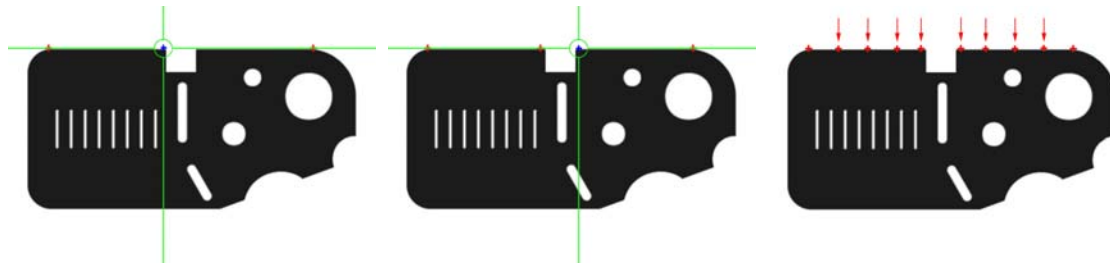

**The single edge probe seeds the endpoints of the line and then probes additional seed points that enclose the line anomaly. The multiple edge probe is then selected and the remaining points are probed automatically.**

### *Recovering from data errors*

Data errors are rare when the part, stage and optical system are clean and well maintained, and the lighting, contrast and brightness are properly adjusted. In addition, the QC-300 is extremely forgiving of typical cleanliness and lighting issues. However, it is possible that an occasional data error will occur while the Multiple edge probe is attempting to collect data from feature locations calculated from the seed points and the specified number of total data points.

When a data error occurs, the system switches from automatic probing using the multiple edge probe to manual probing using the single edge probe, and prompts the operator to either complete the measurement with the available points, or to probe the remaining points manually. When the operator elects to continue probing, he or she is guided to the required points by the green arrow. In either case the operator must press the Finish key to complete the measurement.

While it is not expected that measurements would be conducted on a dirty stage like the one shown in this example of a circle measurement, this dirty stage was used to produce a data error and illustrate the error recovery process.

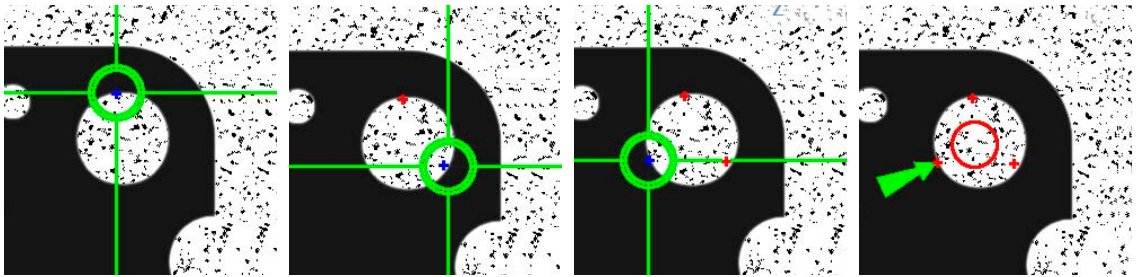

*The Multiple edge probe seeds three points and user is prompted to move the green arrow into the red circle*

When the seed points are probed the red target circle is displayed and the stage is positioned to place the green arrow in the target circle. The system begins to probe the remaining points automatically, however, the stage is dirty and makes the feature edge indistinct producing a data error. The operator is then asked to complete the measurement using the existing points or probe the remaining points manually using the single edge probe.

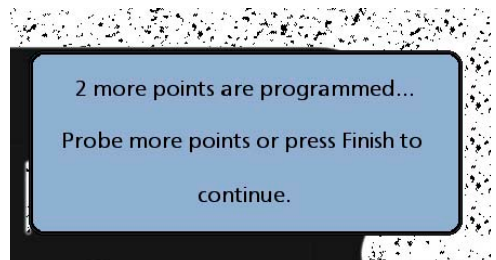

When the operator elects to continue probing the remaining points, the green arrow points to each missing point which is signified by a large X. When the stage is moved to position the single edge probe and arrow at the X and the Enter button is pressed, the next missing point is shown and the green arrow points to it. When all the remaining missing points are entered, the Finish key is pressed to complete the measurement and store the feature data in the Feature list.

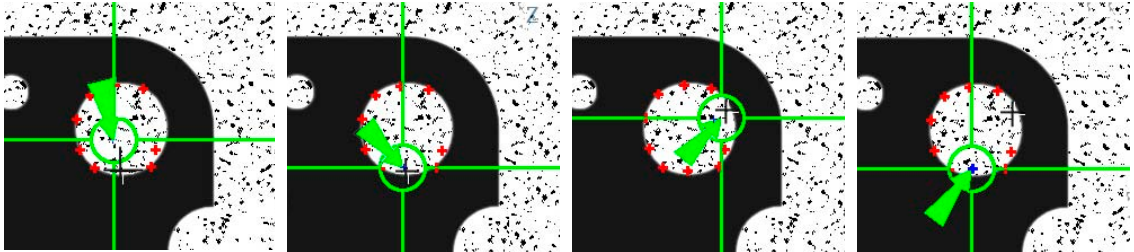

*The Multiple edge probe seeds three points and user is prompted to move the green arrow into the red circle*

The feature and probed points can be reviewed in detail by touching the View button if desired.

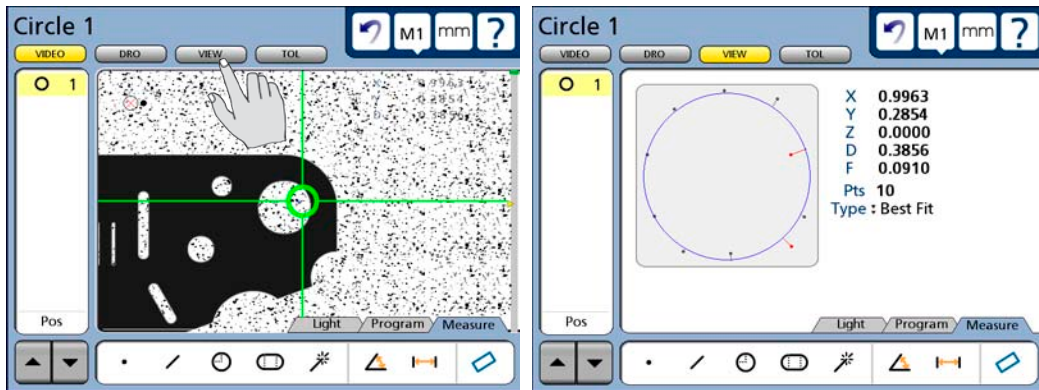

# Chapter 6:

# Measuring

Measurements can be conducted using video edge detection probes or using crosshairs. Measurements can be limited to probing feature points, or can include the construction or creation of new features in addition to probing. However measurements are conducted, the fundamental measurement process and the tools required to perform measurements remain unchanged. Here's what you'll find in this chapter:

Measurement activities.....	66
The measurement process .....	66
Establishing the measurement reference .....	67
Leveling the part (optional) .....	67
Skewing the part .....	68
Creating a datum zero point .....	69
Probing and measuring features .....	73
Probing with Measure Magic .....	73
Probing specific feature types.....	74
Probing process.....	75
Probing with crosshairs and video edge detection.....	76
Probing specific feature types.....	77
Constructing features .....	85
Point constructions.....	85
Line constructions.....	94
Distance constructions .....	111
Circle constructions .....	128
Arc constructions .....	131
Angle constructions .....	133
Creating features .....	135
Creating a point.....	135
Creating a line.....	136
Creating a circle .....	136
Creating an arc .....	137
Creating a slot .....	137
Creating a rectangle .....	138

## Measurement activities

QC-300 measurement sessions can include one or all of the following activities:

- Establishing a measurement reference
- Probing and measuring features
- Constructing features
- Creating features

## The measurement process

The basic measurement process shown here is identical for all feature types. The details of individual measurement steps are described in the remaining pages of this section.

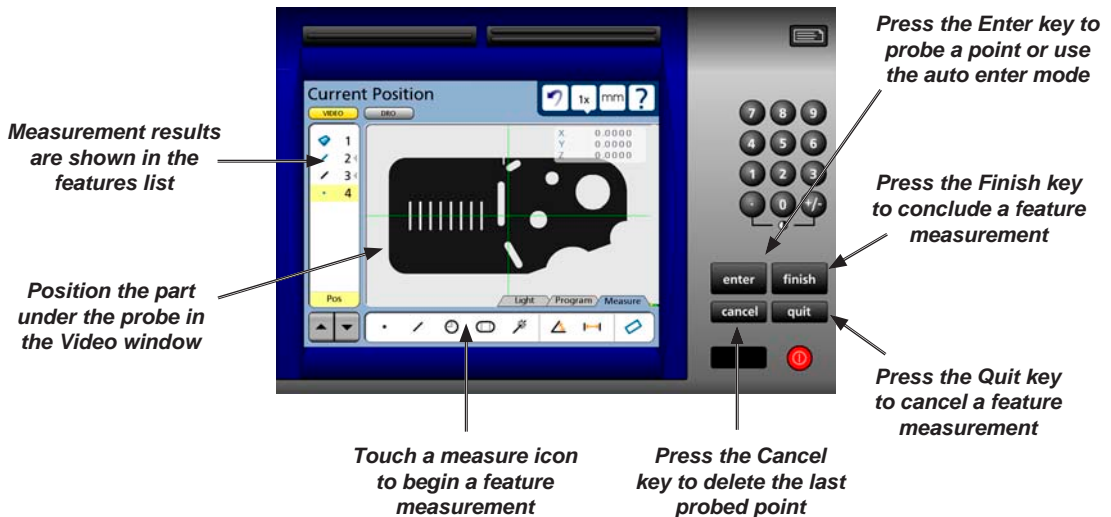
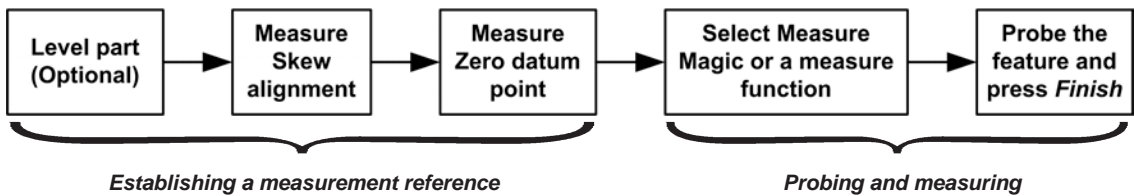

### NOTE

Tools and controls for probing features and conducting measurements are discussed in detail in [Chapter 3: User Interface](#).

**NOTE**

When video probes are used, the stage and optical system must be well maintained, free of scratches and other damage and clean. The optical magnification and part lighting must be prepared as described in [Chapter 5: Probes](#).

## Establishing the measurement reference

A reliable measurement reference must be established before part features can be probed and measured. This reference will be created by the user and ensures a level part surface, precise part alignment and a coordinate origin or datum zero. Reference features are presented in the feature list in blue, other features are presented in black.

### Leveling the part (optional)

When the surface plane of the part is not orthogonal to the measurement axis, small cosine errors can be generated during the measuring process. These errors can be minimized or eliminated by leveling the part.

**CAUTION**

Leveling is not required in most well-maintained systems. Additionally, if the depth of field of the lens system is not much less than the level error, no benefit can be gained from leveling the part.

To level the part:

- 1 Touch the Video window button and then touch the Skew/Level Measure icon.

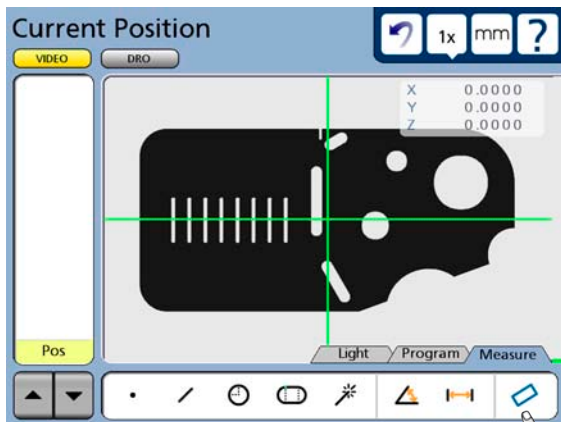
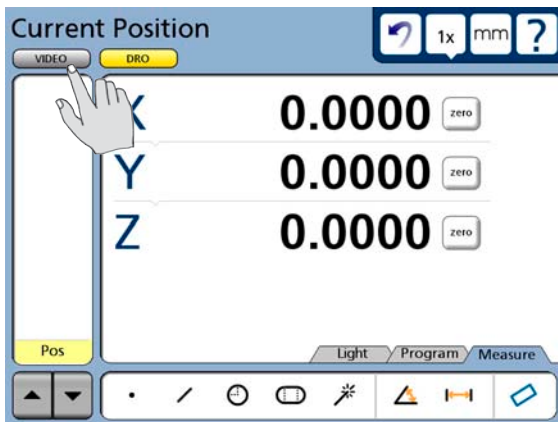

2 Touch the Level icon and perform the leveling measurement by probing three or more points that are well distributed across the surface of the desired part plane. Use the Crosshair to probe, move the Z-axis of the stage to focus the part surface under the Crosshair and then press the Enter key to enter each point. Press the Finish key to complete the level measurement. The level plane feature will be added to the Features list in blue.

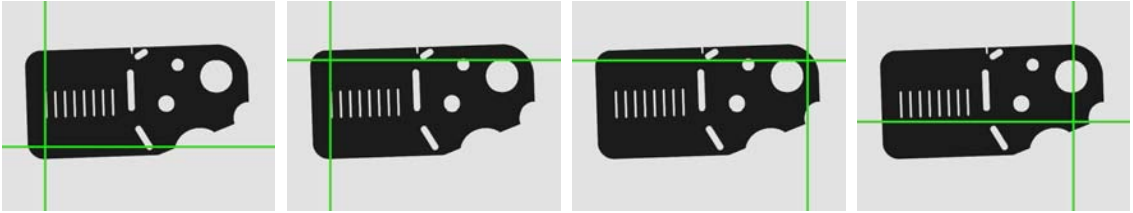

*The four corners of the Metronics quickie slide are probed to perform part leveling*

## Skewing the part

When the part is misaligned (twisted) in the X-Y plane, errors can be generated during the measurement process. These errors can be eliminated by creating a skew alignment for the part.

The skew alignment includes a precise measurement of the part misalignment. Once the misalignment is known to the system, subsequent feature measurements are automatically compensated to eliminate misalignment errors. Measurement data in the DRO will reflect measurements of a perfectly aligned part.



To skew the part:

1 Touch the Skew/Level Measure icon.

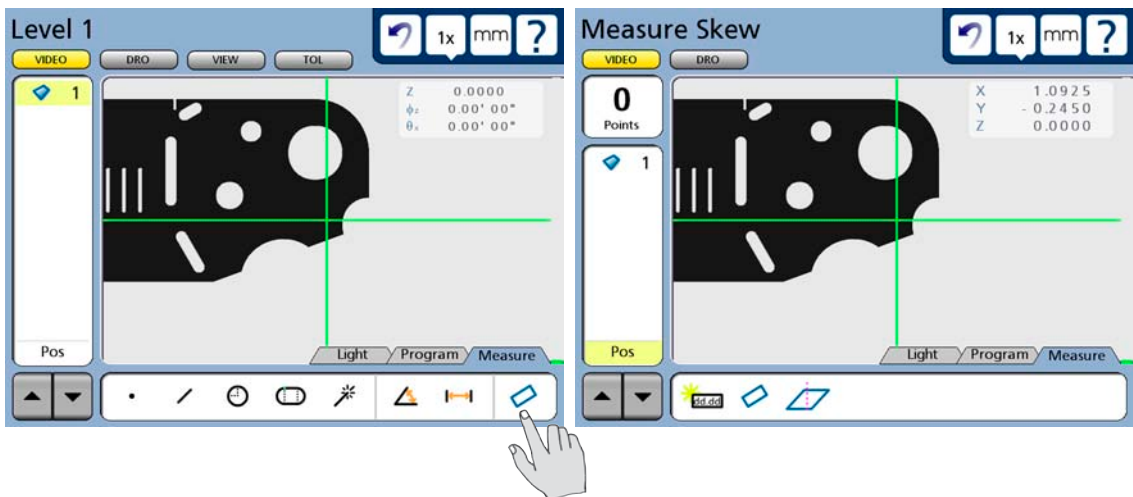

2 Perform the skew alignment by probing 2 or more points well distributed along the entire length of the desired part reference edge. Press the Enter key to enter each point. Press the Finish key to complete the Skew measurement. The skew line feature will be added to the Features list in blue.

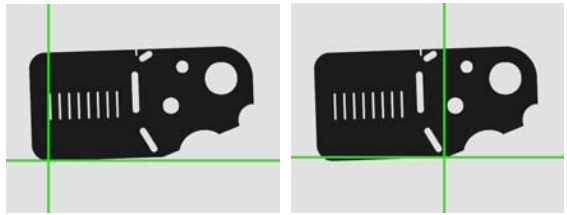

*Two points are probed on the bottom edge to perform a skew alignment on the X-axis*

## Creating a datum zero point

Creating the datum zero point is the final step in establishing a valid Cartesian or polar coordinate system for subsequent measurements. The datum zero point will be used as the origin of Cartesian or polar systems. The datum zero point can be positioned in any location that satisfies the measurement requirements of the user and can be created by probing a point or by constructing a point from parent features.

### Probing a datum zero point

The datum zero point can sometimes be created directly by probing a point. Simple probing is more often possible when the part is precisely aligned in the stage.

To probe a datum zero point:

1 Touch the Point Measure icon.

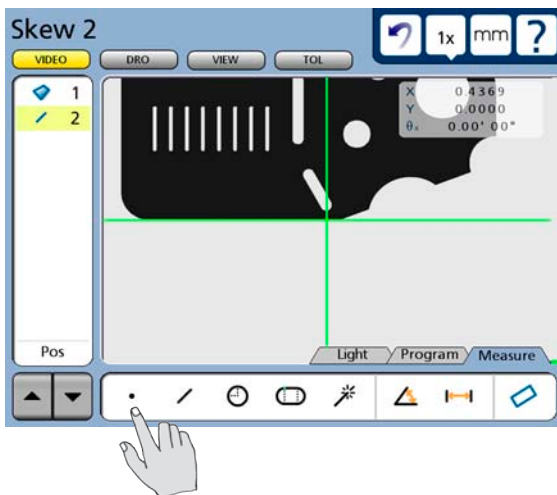

2 Use the crosshair to probe the desired point for the datum zero, and then press the Finish key. The point will be added to the Features list in blue.

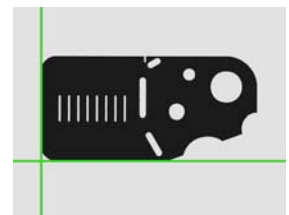



- 3 Select the DRO window, and while the point feature is selected touch the X and Y axis Zero buttons to establish a datum zero at the probed point.

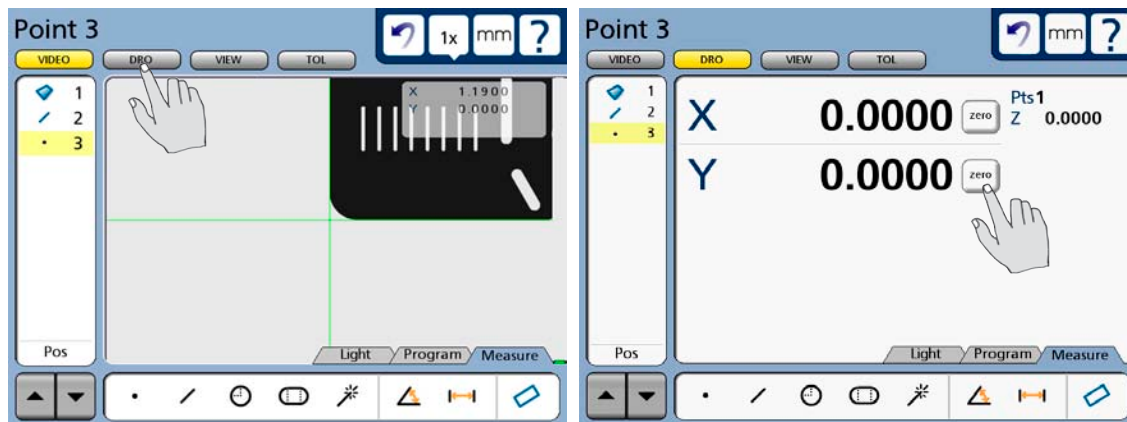

### Constructing a datum zero point

The datum zero point can be constructed from parent features when simply probing the desired point is not possible.

It would not be possible to provide a single description of this process for all measurement applications that require feature constructions to create a datum zero point. However, the concept illustrated by the following example and the construction techniques described later in this chapter can be used to construct a datum zero point for any measurement application.

In this example, after the part skew is performed, a datum zero point is constructed at the intersection points of the X-axis along the bottom of the part (skew axis), and the Y-axis along the left side of the part.

To construct the datum zero point:

- 1 Touch the Measure Magic or the Measure Line icon.

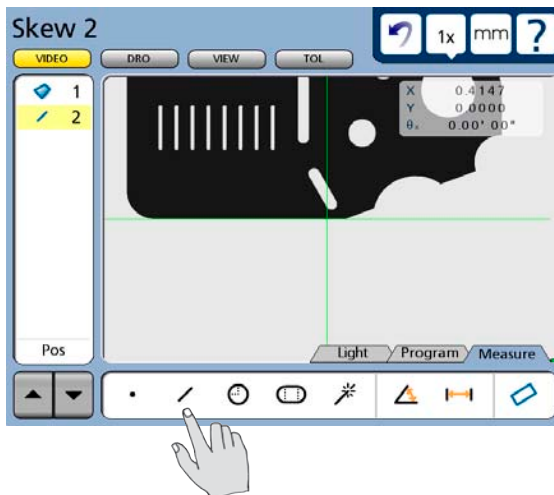

2 Probe two or more points well distributed along the left side of the part, and then press the Finish button. The line feature will be added to the Features list.

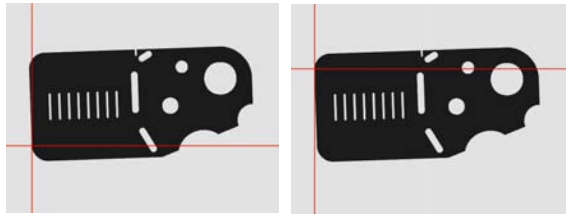

3 Touch the Measure Point icon, and the touch the line probed on the left side of the part in the Features list and then press the Enter key. A check mark will appear next to the line and the skew line will be highlighted in the Features list.

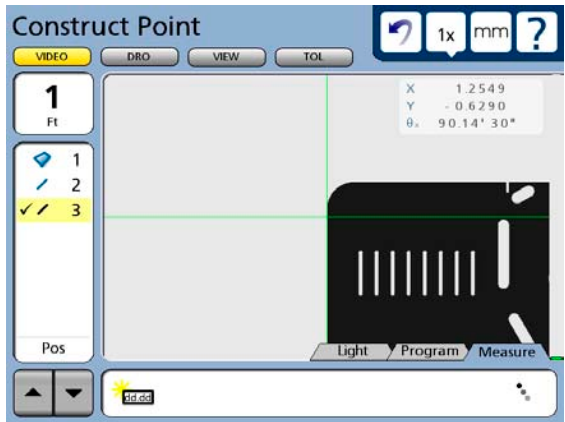
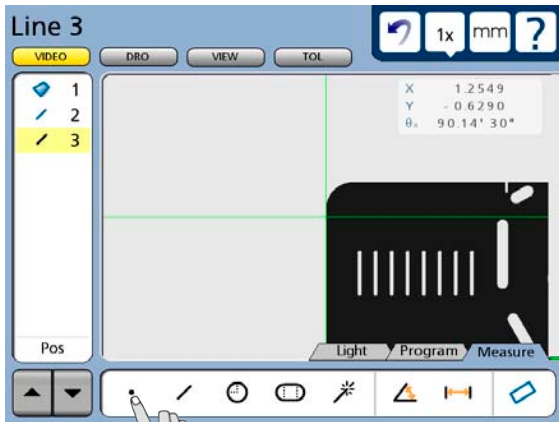

4 Press the Enter key. A check mark will appear next to the skew line. Press the Finish key to complete the point construction.

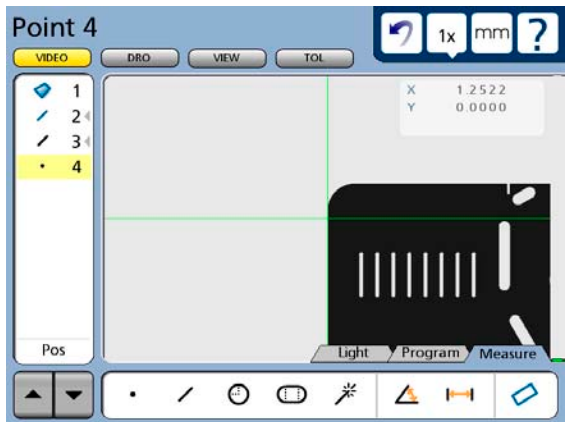
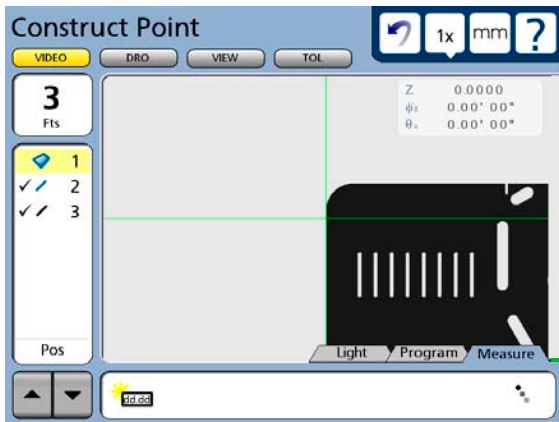

- 5 Touch the constructed point in the Features list and then select the DRO window.

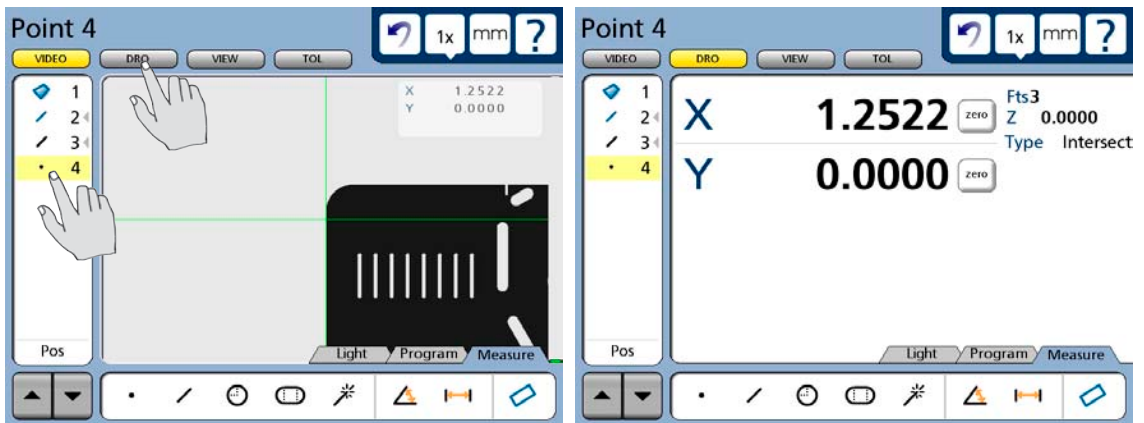

- 6 Touch the Zero buttons of the X and Y axes to define the point location as the zero datum.

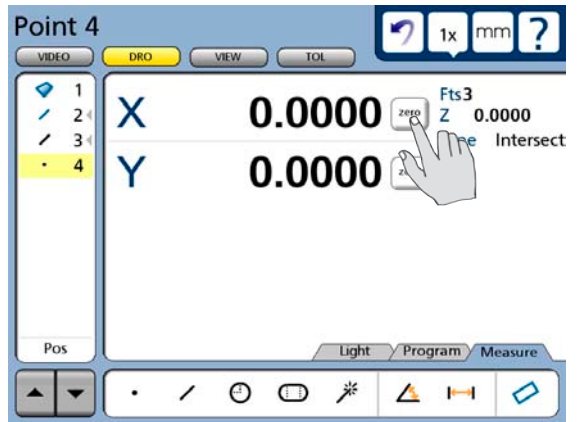

- 7 Select the View window to see the zero datum at the intersection of the X and Y axes.

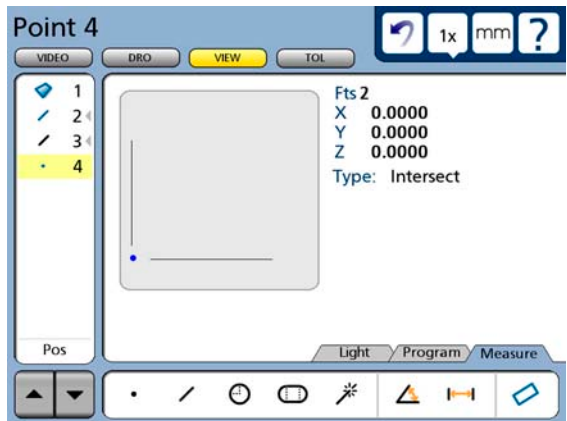

## Probing and measuring features

Part features are measured by creating a part datum, and then by probing points that define the feature's shape and location. Feature points can be probed using Measure Magic or by using a specific measurement function such as the line or circle function. Measurement functions or measure magic are selected by touching a measure icon in the measure toolbar. Measurement results are shown in the Features list, DRO overlay, DRO window and View window.

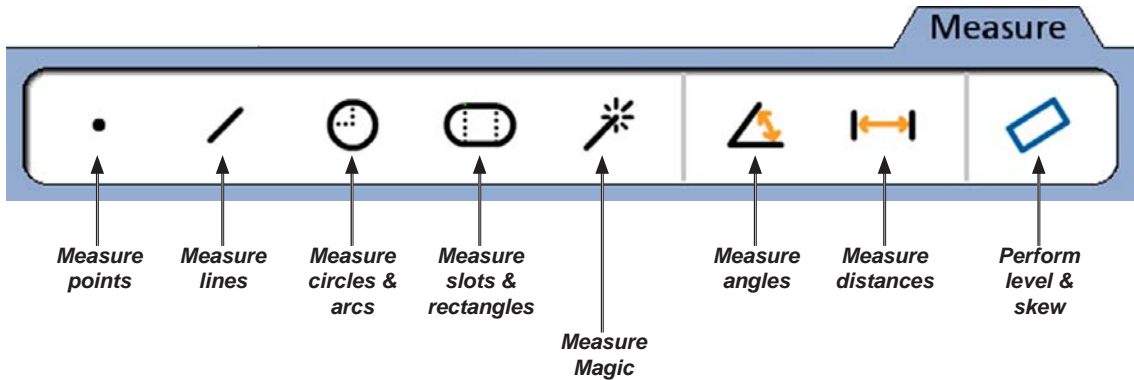

*The measure toolbar contains icons for measurement functions and measure magic*

### Probing with Measure Magic

Measure Magic analyzes feature data collected by part probing and automatically determines the feature type. Measure Magic supports the following feature types in the QC-300:

- Points
- Lines
- Circles
- Arcs
- Slots

When Measure Magic is used, and more than the minimum number of points required to define a feature type are collected, the feature type can be changed manually by the user if the wrong feature type is assigned.

To probe a feature using measure magic, touch the measure magic measure icon, probe points on the desired feature and then press the Finish key.



## Probing specific feature types

When measure magic is not used a measure icon must be touched before each specific feature type is probed. However, a series of features of the same type can be probed by touching the desired measure icon and then touching multiple measurement icon.

### Probing a single specific feature type

To probe a single feature of a specific type, touch the desired measure icon, probe points on the feature and then press the Finish key. A measure icon must be touched again to measure the next feature.

In this example the circle icon is touched to measure a single circle.



When a specific measure function is used to probe the feature, the feature type cannot be changed once it is added to the feature list.

### Probing multiple specific feature type

To probe a series of features of a specific type, touch the desired measure icon, touch the multiple measurement icon, probe points on each feature pressing the Finish key to conclude each feature measurement. In this example icons are touched to probe multiple circles.

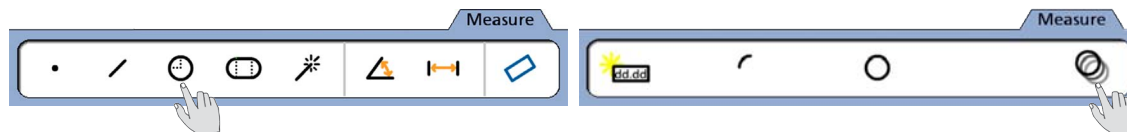

*Touch the circle icon for circle measurements...*

*and then touch the multiple measurement icon to measure a series of circle features*

When a specific measure function is used to probe a series of similar features, the feature type cannot be changed once features have been added to the feature list.

**Probing process**

The feature probing process is essentially the same for all feature types.



*Touch the desired measure icon*

*Probe and enter features, then press Finish to complete measurements*

*Results are displayed in the Video, DRO and View windows*

**Supported feature types**

The following feature measurements are supported by the QC-300:

- Points
- Lines
- Arcs
- Circles
- Slots
- Rectangles
- Distances
- Angles

Features can be probed manually or semi-automatically as part of a program.



**NOTE**

Manual probing is discussed in Chapter 5: Probes. Semi-automatic probing is discussed in Chapter 8: Programming.

### **Backward/forward annotation**

Forward annotation is used to specify a required number of probed points for each feature type. Backward annotation allows the user to probe any number of points beyond the minimum requirement for any feature type. When using forward annotation, the number of remaining required number of points is shown in the top left of the screen. As points are probed this number counts down. Backward annotation simply displays the number of points as they are entered. Some users prefer forward annotation because it establishes a uniform number of points for feature measurements. For example, forward annotation can be set to require 4 points when measuring a circle instead of the minimum three.

When forward annotation is used, the system automatically displays the feature after the last required point is entered. It is not necessary to press the Finish key to conclude forward annotation measurements.



#### **NOTE**

**Users can toggle between backward and forward annotation in the Measure setup screen. Please refer to Chapter 10: Setup for more information regarding backward and forward annotation.**

### ***Probing with crosshairs and video edge detection***

Please refer to Chapter 5: Probes for details regarding probing features with crosshairs and video edge detection. Images used as examples in this chapter show crosshairs. However, the measuring concepts apply equally well to crosshair and video edge detection probes.

Video edge detection probes provide additional flexibility in terms of acquiring points reliably on feature edges and can probe many points automatically when lines, circles and arcs are being probed using the Multiple edge probe. Please refer to Chapter 5: Probes for more details regarding video edge detection and the Multiple edge probe.

### Probing specific feature types

While the probing process is essentially the same for all feature types, the minimum number of points required and the geometric placement of these points are different. The unique requirements for probing each feature type are described in the remainder of this section.

#### Probing points

A minimum of one probed point is required to measure a point. Multiple points can be probed if the feature location is indistinct and it is considered a benefit to use the geometric average of many probed locations.

When a single point is probed, Measure Magic will correctly recognize a point and assign the correct feature. However, when multiple points are probed, it is possible that the wrong feature type will be assigned. If the wrong feature type is assigned, it can easily be changed by selecting the correct feature from a menu of alternatives in the DRO window.

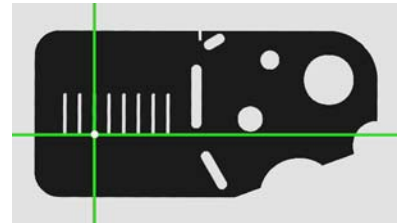

*A single point is probed to measure a point*

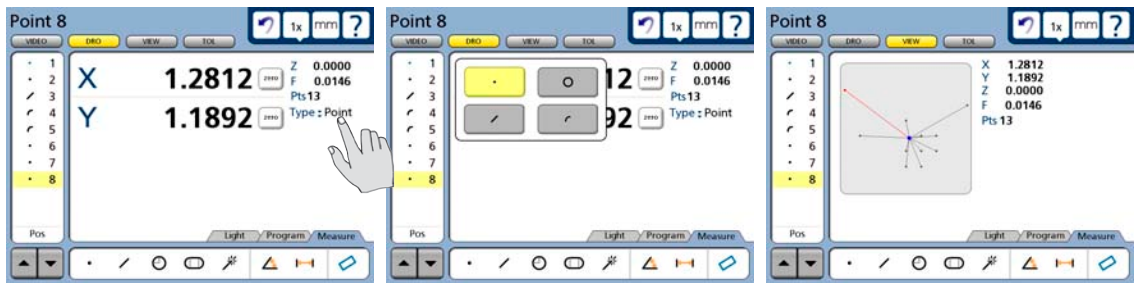

*Touch the feature type...*

*to display the menu of alternative types*

*Probed points are shown in the View window*

Measurement results are shown in the Features list, View window and DRO window. Results are also shown in the DRO overlay. The feature graphic in the View window shows the feature and the points used to define it. Errors are shown as whiskers connecting the probed points to the feature. The maximum errors are shown in red and are used in the calculation of form. The DRO window shows the number of points used, the form and the coordinate location of the feature. When only one point is probed, the form error is zero. When more than one point is probed, the form error is the sum of the two greatest opposing error magnitudes.



## Probing lines

A minimum of two probed points is required to measure a line. There is no practical limit to the number of points that can be probed, and in general accuracy is increased by probing more points.

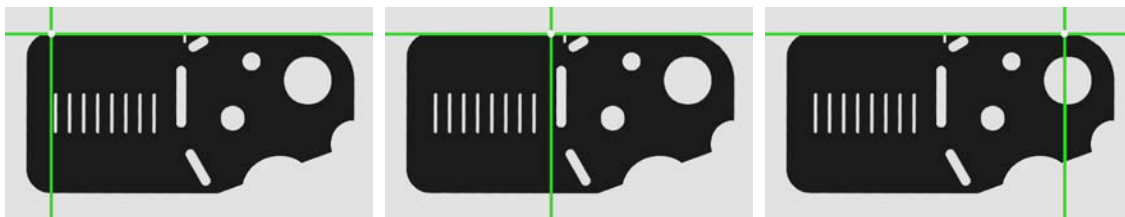

*Three points are probed to measure a line*

When only two points are probed, Measure Magic will correctly recognize a line and assign the correct feature. However, when more than two points are probed, it is possible that the wrong feature type will be assigned. If the wrong feature type is assigned, it can easily be changed by selecting the correct feature from a menu of alternatives in the DRO window.

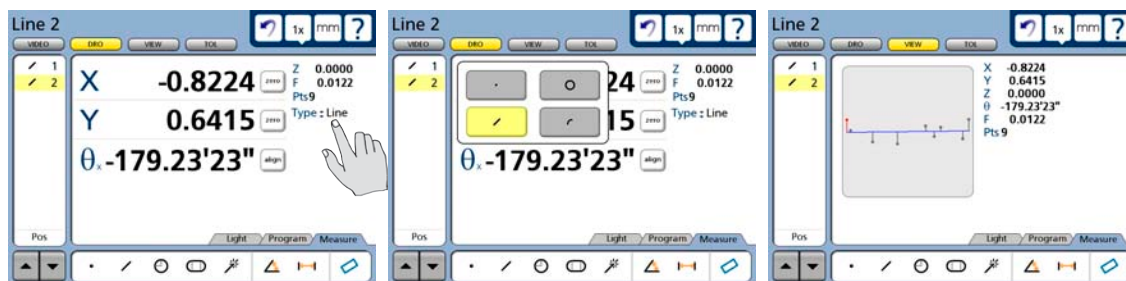

*Touch the feature type...*

*to display the menu of alternative types*

*Probed points are shown in the View window*

Best-fit algorithms are used to define lines when more than two points are probed. The line fit to the probed data can also be changed by selecting the desired fitting algorithm from a menu in the DRO window. Please refer to [Chapter 12: Reference Materials](#) for details regarding the fitting algorithms.

Measurement results are shown in the Features list, View window and DRO window. Results are also shown in the DRO overlay. The feature graphic in the View window shows the feature and the points used to define it. Errors are shown as whiskers connecting the probed points to the feature. The maximum errors are shown in red and are used in the calculation of form. The DRO window shows the number of points used, the angular orientation of the line, the coordinate location of the center of the line and the form error. When only two points are probed, the form error is zero. When more than two points are probed, the form error is the sum of the two greatest opposing error magnitudes.

## Probing arcs

A minimum of three probed points is required to measure an arc. There is no practical limit to the number of points that can be probed, and in general accuracy is increased by probing more points.

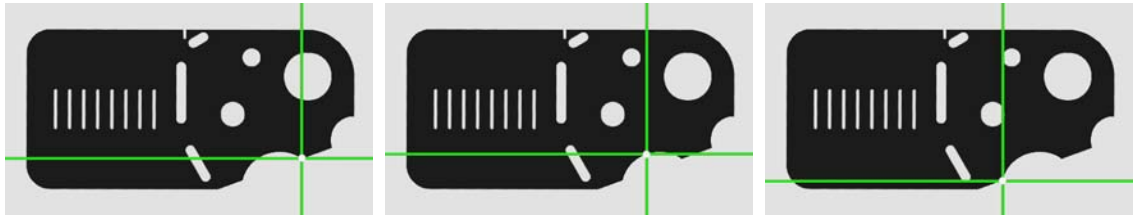

Three points are probed to measure an arc

When the arc is less than 185 degrees, Measure Magic will correctly recognize the arc and assign the correct feature. However, when the arc is 185 degrees or more, it is likely that Measure Magic will assign the circle feature type to the data. If the arc is shallow, Measure Magic might mistakenly assign a line feature. If the wrong feature type is assigned, it can easily be changed by selecting the correct feature from a menu of alternatives in the DRO window. Points must be gathered in sequence from the beginning to the end of the arc when the Multiple edge probe is used. More details are contained in [Chapter 5: Probes](#).

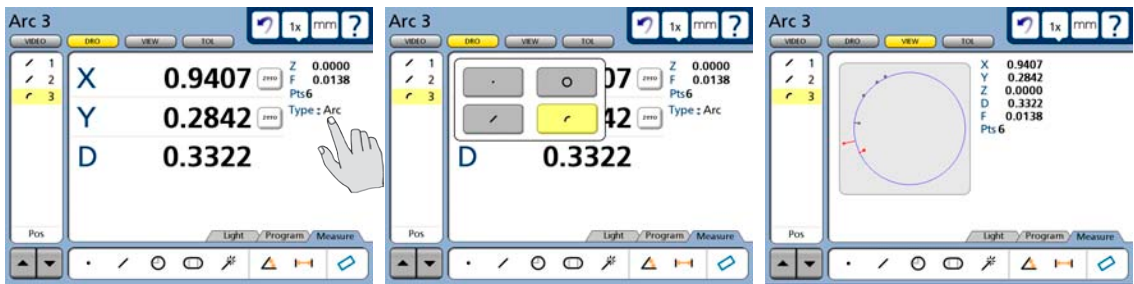

Touch the feature type...

to display the menu of alternative types

Probed points are shown in the View window

View window shows the feature and the points used to define it. Errors are shown as whiskers connecting the probed points to the feature. The arc will be shown with data point form errors in blue and the greatest two opposing form errors in red.

The DRO window shows the number of points used, the radius and diameter of the arc, the coordinate location of the center of the arc and the form error. The feature graphic in the View window shows the feature and the points used to define it. Errors are shown as whiskers connecting the probed points to the feature. The maximum errors are shown in red and are used in the calculation of form. When only three points are probed, the form error is zero. When more than three points are probed, the form error is the sum of the two greatest opposing error magnitudes.

### Probing circles

A minimum of three probed points is required to measure a circle. There is no practical limit to the number of points that can be probed, and in general accuracy is increased by probing more points.

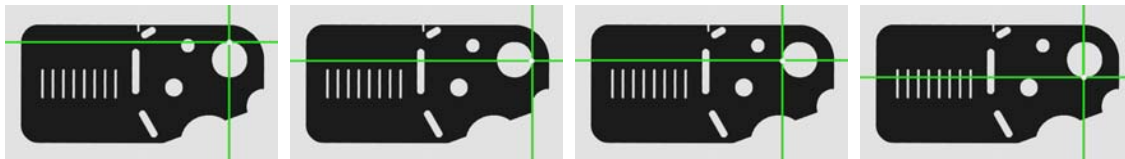

*Four points are probed to measure a circle*

When 185 degrees or more of the circle is probed, Measure Magic will correctly recognize the circle and assign the correct feature. However, when less than 185 degrees is probed, it is likely that Measure Magic will assign the arc feature type to the data. If the wrong feature type is assigned, it can easily be changed by selecting the correct feature from a menu of alternatives in the DRO window.

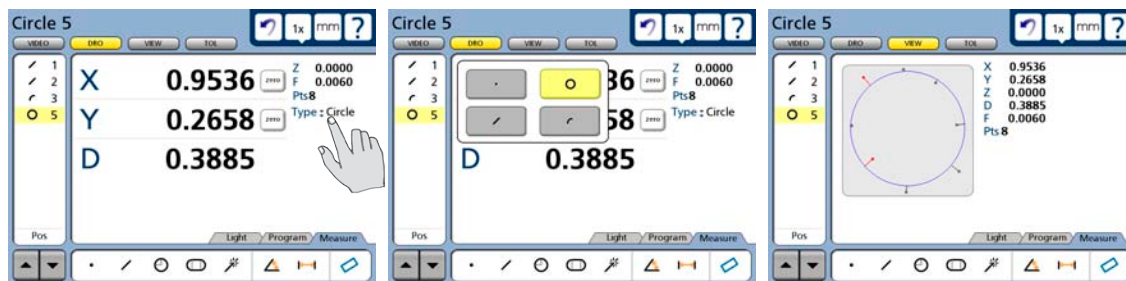

*Touch the feature type...*

*to display the menu of alternative types*

*Probed points are shown in the View window*

A best-fit algorithm is used to define the circle when more than three points are probed. The circle fit to the probed data can also be changed by selecting the desired fitting algorithm from a menu in the DRO window. Please refer to [Chapter 12: Reference Materials](#) for details regarding the fitting algorithms.

The View window shows the feature and the points used to define it. Errors are shown as whiskers connecting the probed points to the feature. The circle will be shown with data point form errors in blue and the greatest two opposing form errors in red.

Measurement results are shown in the Features list, View window and DRO window. Results are also shown in the DRO overlay. The feature graphic in the View window shows the feature and the points used to define it. Errors are shown as whiskers connecting the probed points to the feature. The maximum errors are shown in red and are used in the calculation of form. The DRO window shows the number of points used, the radius, diameter, coordinate location of the center of the circle and the form error. When only three points are probed, the form error is zero. When more than three points are probed, the form error is the sum of the two greatest opposing error magnitudes.

## Probing slots

Five probed points are required to measure a slot. The five points must be probed in a prescribed pattern, and must be probed in clockwise or counterclockwise order.

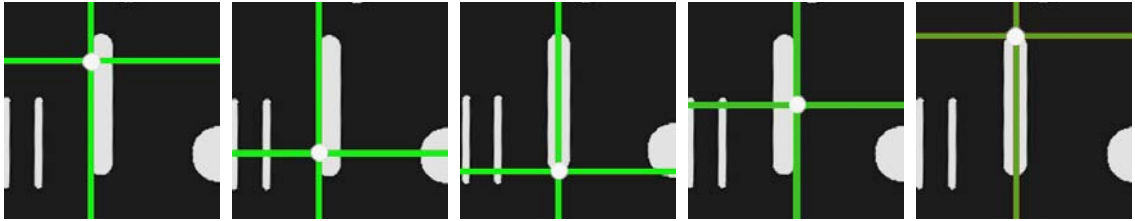

As shown above, the correct pattern of points probed around the slot is:

- Two points well distributed along one long side, followed by
- One point on the closest end, followed by
- One point on the approximate center of the second long side, followed by
- The last point on the remaining end



### CAUTION

**Probing a different pattern of points, or probing out of either clockwise or counterclockwise order will result in erroneous slot measurements.**

When the slot is probed as described above, Measure Magic will assign the correct feature. However, occasionally Measure Magic will assign the wrong feature type to the data. If the wrong feature type is assigned, it can easily be changed by selecting the correct feature from a menu of alternatives in the DRO window.

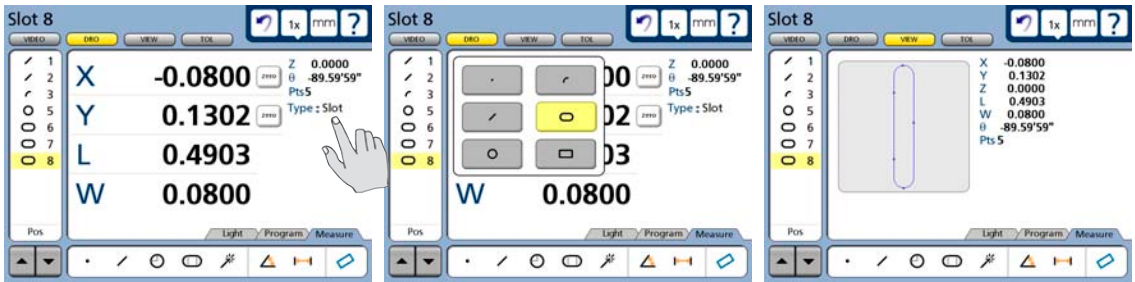

*Touch the feature type...*

*to display the menu of alternative types*

*Probed points are shown in the View window*

Measurement results are shown in the Features list, View window and DRO window. Results are also shown in the DRO overlay. The feature graphic in the View window shows the feature and the points used to define it. The DRO window shows the number of points probed, the coordinate location of the center of the slot, the slot length, the slot width and the angle of the slot center line with respect to the skew axis.

## Probing rectangles

Five probed points are required to measure a rectangle. The five points must be probed in a prescribed pattern, and must be probed in clockwise or counterclockwise order.

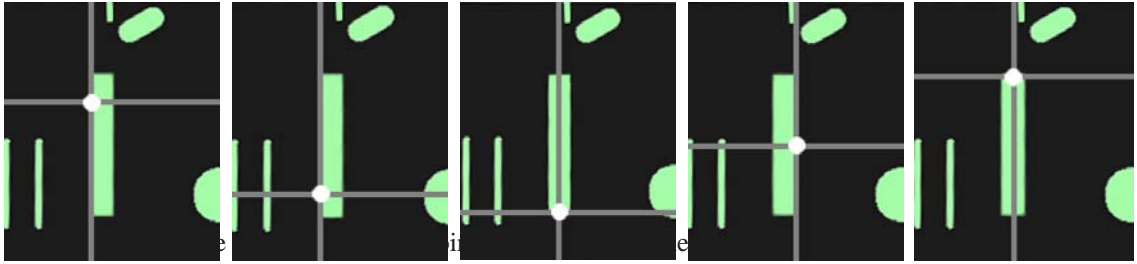

- Two points well distributed along one long side, followed by
- One point on the closest end, followed by
- One point on the approximate center of the second long side, followed by
- The last point on the remaining end



### CAUTION

Probing a different pattern of points, or probing out of either clockwise or counterclockwise order will result in erroneous rectangle measurements.

When the rectangle is probed as described above using Measure Magic, Measure Magic will assign the slot feature. However, the slot feature can easily be changed to a rectangle by selecting the rectangle feature from a menu of alternatives in the DRO window.

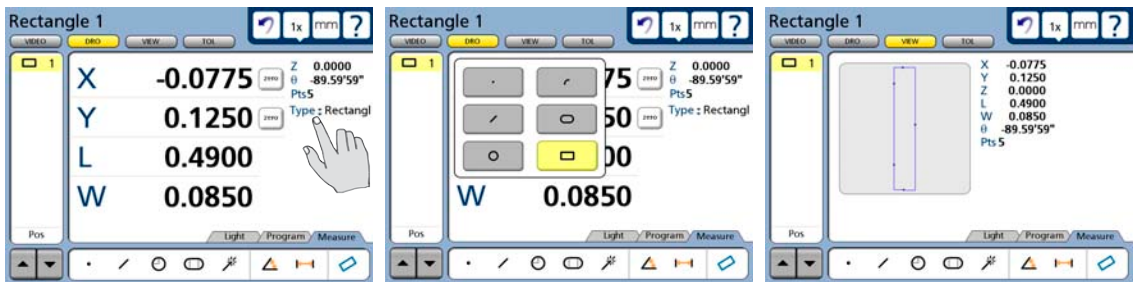

*Touch the feature type...*

*to select the correct rectangle feature type*

*Probed points are shown in the View window*

Measurement results are shown in the Features list, View window and DRO window. Results are also shown in the DRO overlay. The feature graphic in the View window shows the feature and the points used to define it. The DRO window shows the number of points probed, the coordinate location of the center of the rectangle, the rectangle length, the rectangle width and the angle of the rectangle center line with respect to the skew axis.

## Probing distances

Two probed points are required to measure a distance.

Measurement results are shown in the Features list, View window, DRO window and the DRO overlay.

The View window shows the feature and the points used to define it. The DRO window shows the number of points used, the X and Y axis displacements and the distance vector between features.

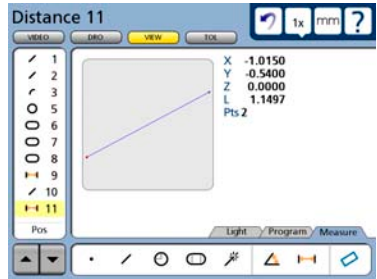
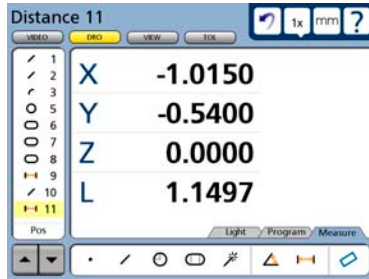
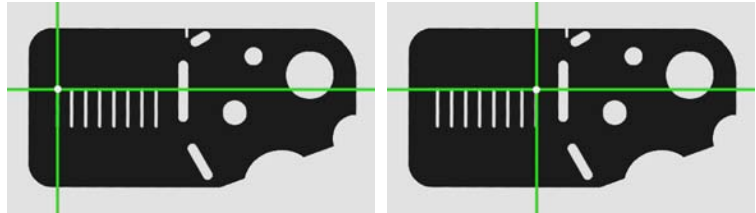

### Probing angles

Four probed points are required to measure an angle. The four points must be probed in a prescribed pattern on the two lines that form an angle. There is no practical limit to the number of points that can be probed, and in general accuracy is increased by probing more points.

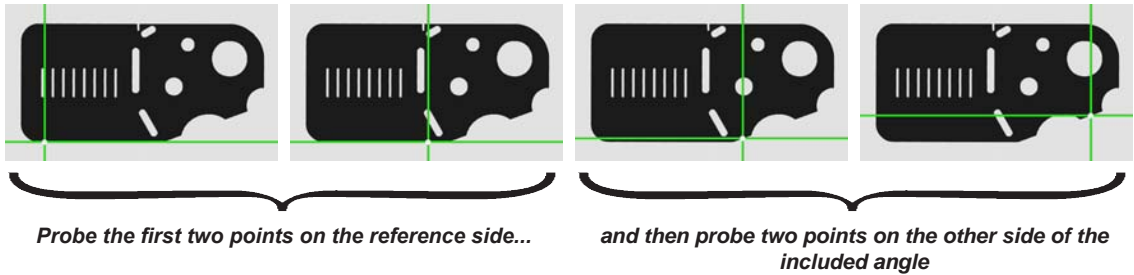

As shown here, the correct pattern of points probed for an angle is:

- A minimum of two points well distributed along the reference side, followed by
- A minimum of two points well distributed along the opposite side of the included angle
- The same number of points must be probed on each of the two sides

The View window shows the feature and the points used to define it. The DRO window shows the number of points probed, the coordinate location of the angle and the angle orientation to the skew axis.

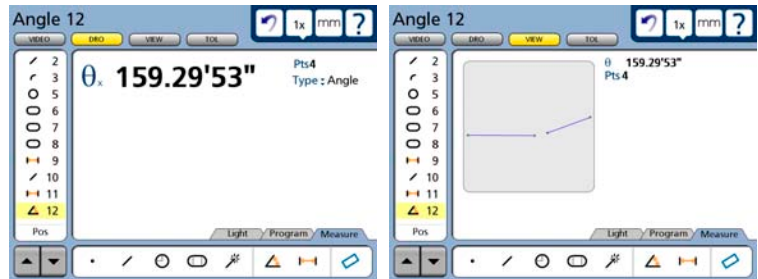

The included angle is shown as the default measurement result, however, the angle type can easily be changed by selecting the desired angle type from a menu of alternatives in the DRO window.

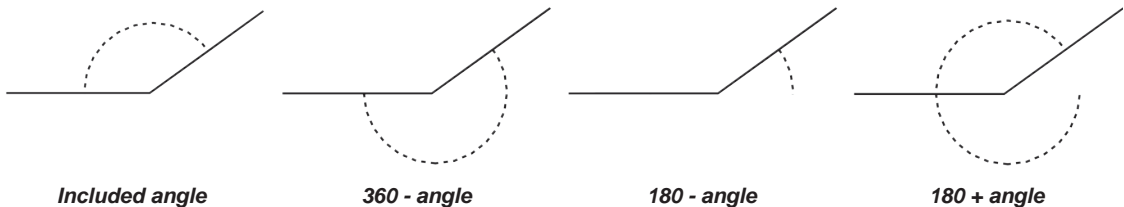

## Constructing features

Features can be constructed from one or more existing features. Existing features used to construct new features are called parent features, and can be features that were measured, constructed or created. Existing features are shown in black, and constructed features are shown in blue in the View window.

### ***Point constructions***

Points can be constructed from:

- Points
- Lines
- Distances
- Circles
- Angles
- Arcs
- Slots
- Rectangles

#### **Point constructed from a point**

A duplicate feature can be useful when it becomes desirable to perform new operations with the original while retaining a copy. To construct a point from an existing point:

- 1 Touch the Measure Point icon
- 2 Touch the desired point in the Features list
- 3 Press the Enter key
- 4 Press the Finish key

The new point feature will be constructed over the original point.

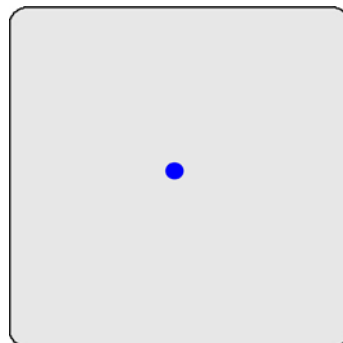

#### **Point constructed from a point and a line**

The point will be constructed where the perpendicular from the original point to the line intersects the line.

To construct a point from an existing point and a line:

- 1 Touch the Measure Point icon
- 2 Touch the desired point feature
- 3 Press the Enter key
- 4 Touch the desired line feature
- 5 Press the Enter key
- 6 Press the Finish key

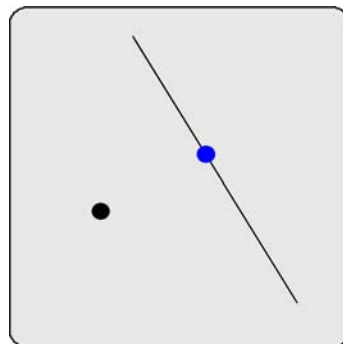

The new point feature will be constructed on the line.



### Points constructed from an arc and a line

Up to three point constructions can be made from an arc and a line:

- Intersection point 1:  
The first intersection of the arc and line
- Intersection point 2:  
The second intersection of the arc and line
- Perpendicular point:  
The intersection of the line and the perpendicular from the arc center to the line

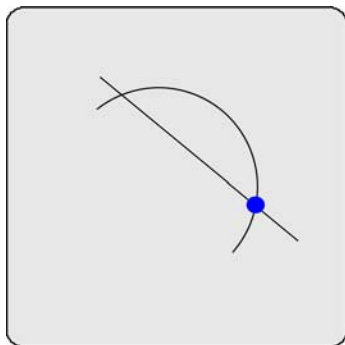

*Intersection point 1*

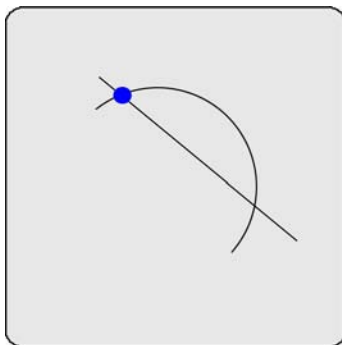

*Intersection point 2*

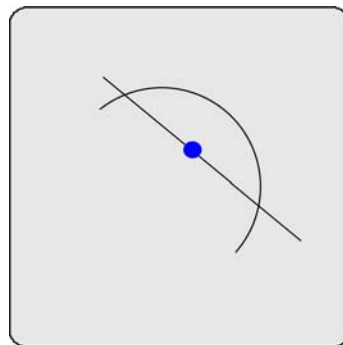

*Perpendicular point*

To construct a point from an arc and a line:

- 1 Touch the Measure Point icon
- 2 Touch the desired arc feature
- 3 Press the Enter key
- 4 Touch the desired line feature
- 5 Press the Enter key
- 6 Press the Finish key

The first intersect point or perpendicular point of the arc and line will be constructed. Alternative point constructions can be selected from the drop-down menu in the DRO window.

### Points constructed from a line

Up to four point constructions can be made from a line:

- Midpoint:  
The center of the line
- End point 1:  
The first endpoint of the line
- End point 2:  
The second endpoint of the line
- Anchor point:  
The intersection of the line and the perpendicular from the datum to the line

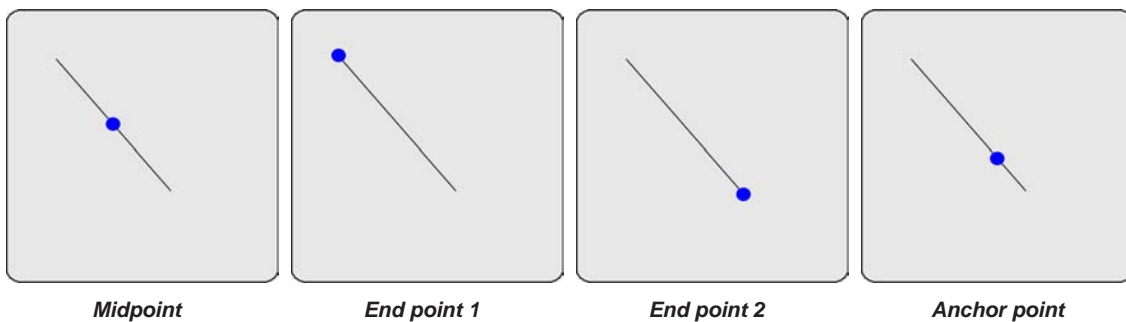

To construct a point from a line:

- 1 Touch the Measure Point icon
- 2 Touch the desired line feature
- 3 Press the Enter key
- 4 Press the Finish key

The midpoint of the line will be constructed. Alternative point constructions can be selected from the drop-down menu in the DRO window.

**Point constructed from two lines**

The intersection point of the lines will be constructed. The virtual intersection point will be calculated and shown if the lines do not actually cross.

To construct a point from two lines:

- 1 Touch the Measure Point icon
- 2 Touch one desired line feature
- 3 Press the Enter key
- 4 Touch the other line feature
- 5 Press the Enter key
- 6 Press the Finish key

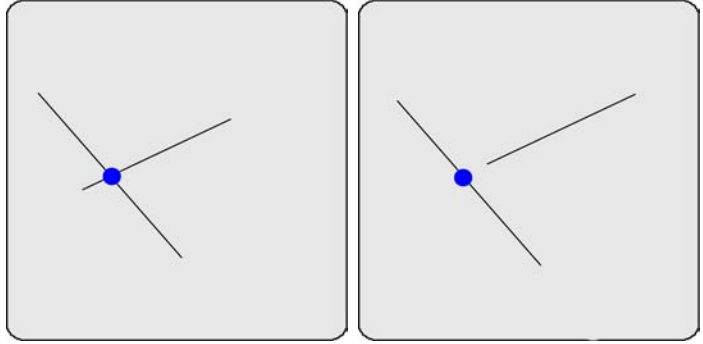

The intersection point or virtual intersection point of the lines will be constructed.

**Points constructed from a distance**

The start and end points of the distance will be constructed.

To construct points from a distance:

- 1 Touch the Measure Point icon
- 2 Touch the distance feature
- 3 Press the Enter key
- 4 Press the Finish key

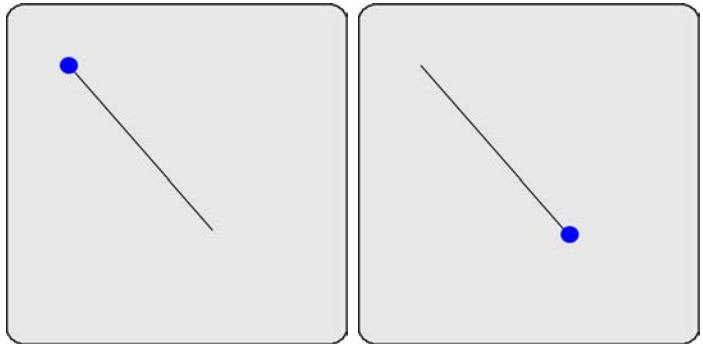

The start point of the line will be constructed. The alternative end point construction can be selected from the drop-down menu in the DRO window.

**Point constructed from a distance and a point**

A point feature will be constructed and offset from the parent point feature by the parent distance feature.

To construct a point from a point and a distance:

- 1 Touch the Measure Point icon
- 2 Touch the point feature
- 3 Press the Enter key
- 4 Touch the distance feature
- 5 Press the Enter key
- 6 Press the Finish key

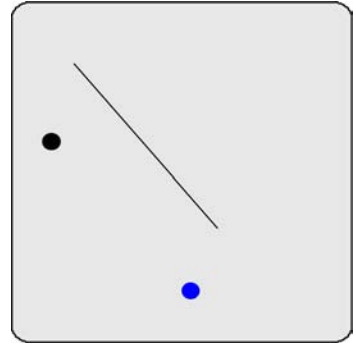

An offset point feature will be constructed.

**Point constructed from a circle**

A point feature will be constructed at the center of a circle.

To construct a point from a circle:

- 1 Touch the Measure Point icon
- 2 Touch the circle feature
- 3 Press the Enter key
- 4 Press the Finish key

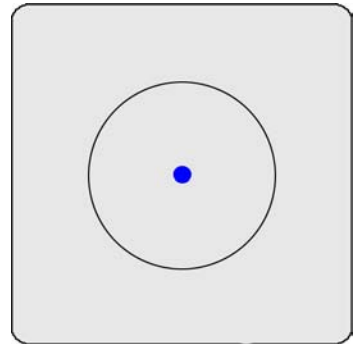

A point feature will be constructed at the center of the circle.

**Points constructed from a circle and a line**

Up to three point constructions can be made from an circle and a line:

- Intersection point 1:  
The first intersection of the circle and line
- Intersection point 2:  
The second intersection of the circle and line
- Perpendicular point:  
The intersection of the line and the perpendicular from the circle center to the line

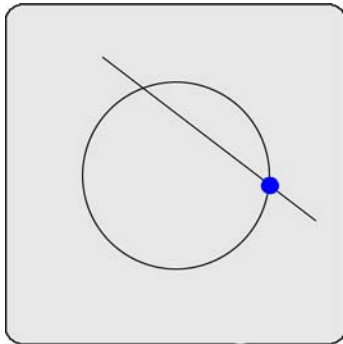

*Intersection point 1*

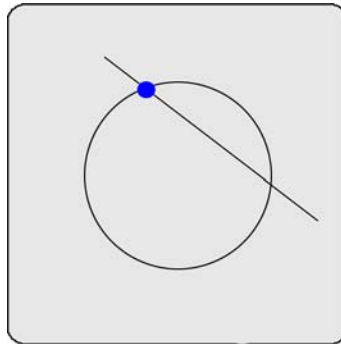

*Intersection point 2*

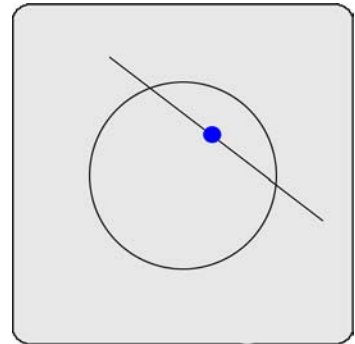

*Perpendicular point*

To construct a point from an circle and a line:

- 1 Touch the Measure Point icon
- 2 Touch the desired circle feature
- 3 Press the Enter key
- 4 Touch the desired line feature
- 5 Press the Enter key
- 6 Press the Finish key

The first intersect point or perpendicular point of the circle and line will be constructed. Alternative point constructions can be selected from the drop-down menu in the DRO window.

### Points constructed from two circles

Up to three point constructions can be made from two circles:

- Intersection point 1:  
The first intersection of the two circles
- Intersection point 2:  
The second intersection of the two circles
- Midpoint:  
The midpoint of the congruent portion of the two circles

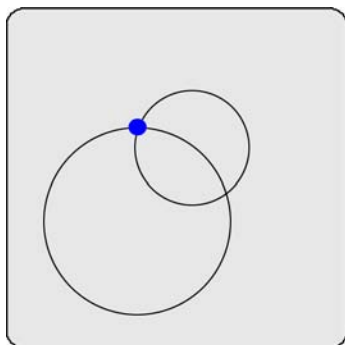

*Intersection point 1*

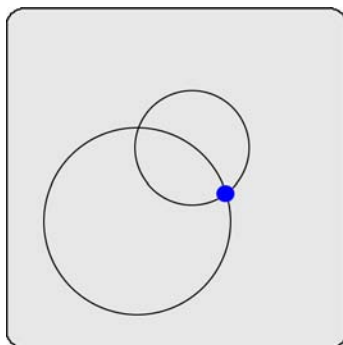

*Intersection point 2*

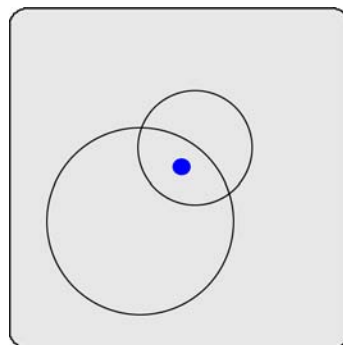

*Midpoint*

To construct a point from two circles:

- 1 Touch the Measure Point icon
- 2 Touch the first circle feature
- 3 Press the Enter key
- 4 Touch the second circle feature
- 5 Press the Enter key
- 6 Press the Finish key

The first intersect point of the two circles will be constructed. Alternative point constructions can be selected from the drop-down menu in the DRO window.

**Point constructed from a slot**

A point feature will be constructed at the center of a slot.

To construct a point from a slot:

- 1 Touch the Measure Point icon
- 2 Touch the slot feature
- 3 Press the Enter key
- 4 Press the Finish key

A point feature will be constructed at the center of the slot.

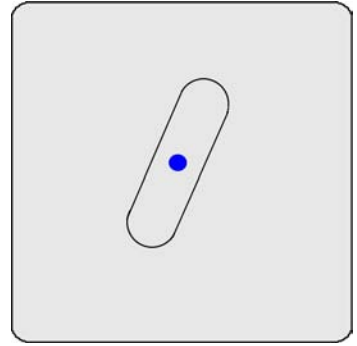
**Point constructed from a rectangle**

A point feature will be constructed at the center of a rectangle.

To construct a point from a slot:

- 1 Touch the Measure Point icon
- 2 Touch the rectangle feature
- 3 Press the Enter key
- 4 Press the Finish key

A point feature will be constructed at the center of the rectangle.

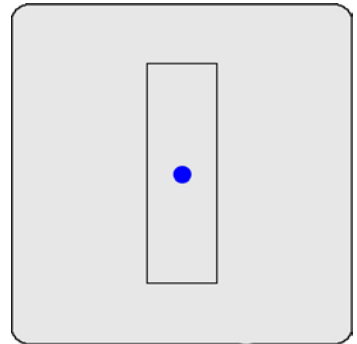
**Point constructed from an angle**

A point feature will be constructed at the apex of the angle.

To construct a point from an angle:

- 1 Touch the Measure Point icon
- 2 Touch the angle feature
- 3 Press the Enter key
- 4 Press the Finish key

A point feature will be constructed at the apex of the angle.

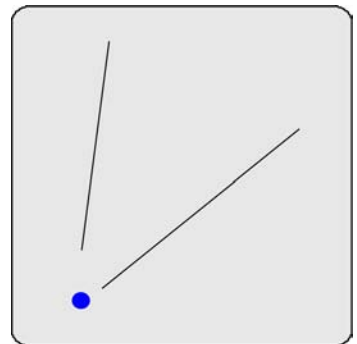

**Point constructed from an arc**

A point feature will be constructed at the center of an arc.

To construct a point from an arc:

- 1 Touch the Measure Point icon
- 2 Touch the arc feature
- 3 Press the Enter key
- 4 Press the Finish key

A point feature will be constructed at the center of the arc.

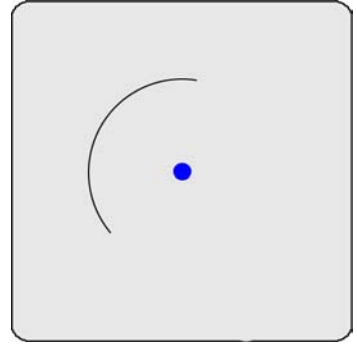
**Point constructed from multiple features**

The geometric center point of multiple features can be constructed from any combination and any number of points, slots, rectangles, circles, and arcs.

To construct a point from multiple features:

- 1 Touch the Measure Point icon
- 2 Touch a feature
- 3 Press the Enter key
- 4 Repeat steps 2 and 3 for all features
- 5 Press the Finish key

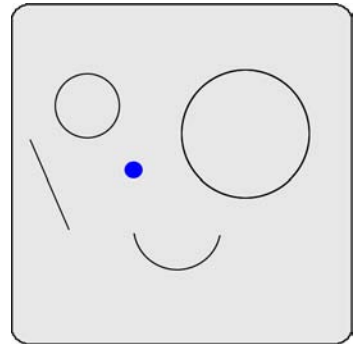

The center point (centroid) of the entire collection of features will be constructed.



## ***Line constructions***

Lines can be constructed from:

- Points
- Lines
- Distances
- Circles
- Angles
- Arcs
- Slots

### **Line constructed from a line**

A duplicate feature can be useful when it becomes desirable to perform new operations with the original while retaining a copy. To construct a line from an existing line:

- 1 Touch the Measure Line icon
- 2 Touch the desired line in the Features list
- 3 Press the Enter key
- 4 Press the Finish key

The new line feature will be constructed over the original line.

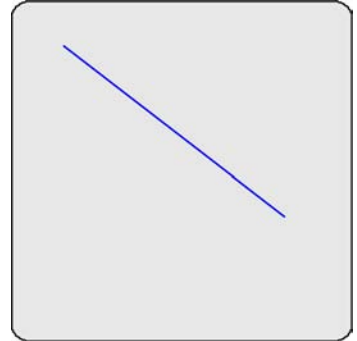

### **Line constructed from two points**

The line feature will be constructed between the two points.

To construct a line from two points:

- 1 Touch the Measure Line icon
- 2 Touch the first point Feature
- 3 Press the Enter key
- 4 Touch the second point Feature
- 5 Press the Enter key
- 6 Press the Finish key

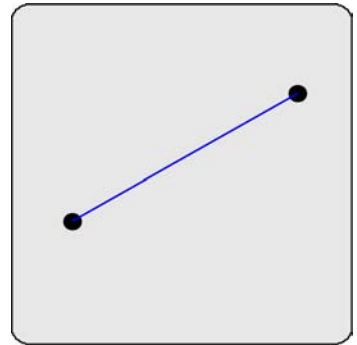

The new line feature will be constructed between the two points.

## Lines constructed from a point and a line

Two line constructions can be made from a point and a line:

- Perpendicular line:  
The line from the point to the line, perpendicular to the line
- Parallel line:  
The line through the point parallel to the line

To construct a line from a point and a line:

- 1 Touch the Measure Line icon
- 2 Touch the point feature
- 3 Press the Enter key
- 4 Touch the line feature
- 5 Press the Enter key
- 6 Press the Finish key

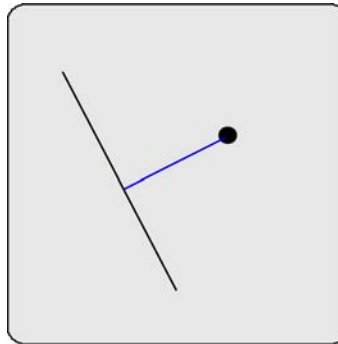

*Perpendicular line*

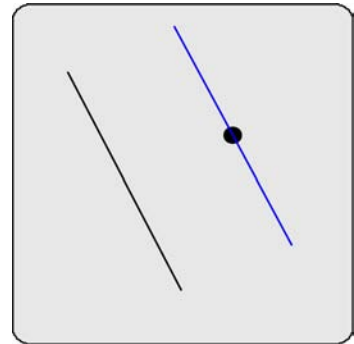

*Parallel line*

The perpendicular line will be constructed. The alternative parallel line construction can be selected from the drop-down menu in the DRO window.

## Line constructed from a distance

The line feature will be constructed over a distance feature.

To construct a line from a distance:

- 1 Touch the Measure Line icon
- 2 Touch the distance Feature
- 3 Press the Enter key
- 4 Press the Finish key

The new line feature will be constructed over the distance feature.

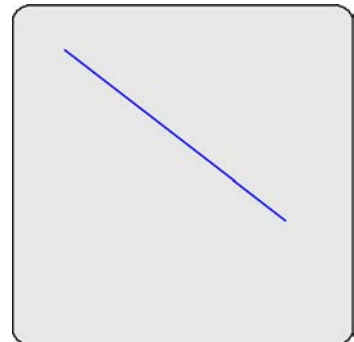

**Lines constructed from a point and a circle**

Up to three line constructions can be made from a point and a circle:

- Two point line:  
The line from the point to the center of the circle
- Tangent line 1:  
The line from the point to the first tangent of the circle
- Tangent line 2:  
The line from the point to the second tangent of the circle

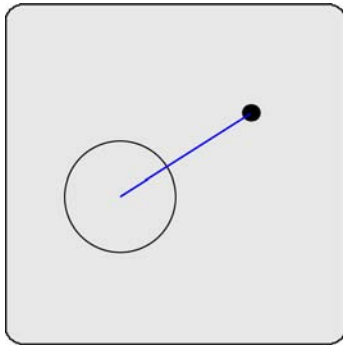

*Two point line*

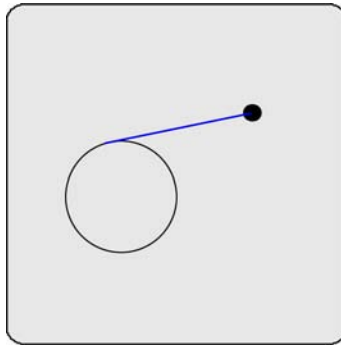

*Tangent line 1*

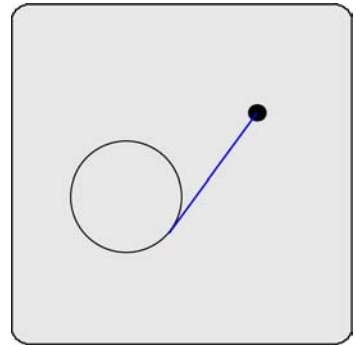

*Tangent line 2*

To construct a line from a point and a circle:

- 1 Touch the Measure line icon
- 2 Touch the point feature
- 3 Press the Enter key
- 4 Touch the circle feature
- 5 Press the Enter key
- 6 Press the Finish key

The two point line will be constructed. Alternative line constructions can be selected from the drop-down menu in the DRO window.

**Line constructed from a point and a slot**

The line will be constructed from the point to the center of the slot.

To construct a line from a point and a slot:

- 1 Touch the Measure line icon
- 2 Touch the point feature
- 3 Press the Enter key
- 4 Touch the slot feature
- 5 Press the Enter key
- 6 Press the Finish key

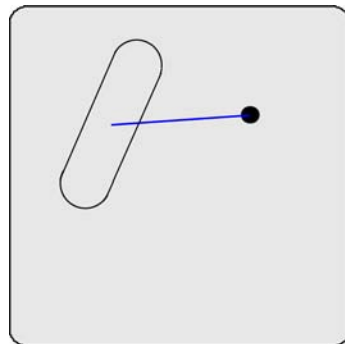

The line will be constructed to the center of the slot.

**Line constructed from a point and a rectangle**

The line will be constructed from the point to the center of the rectangle.

To construct a line from a point and a rectangle:

- 1 Touch the Measure line icon
- 2 Touch the point feature
- 3 Press the Enter key
- 4 Touch the rectangle feature
- 5 Press the Enter key
- 6 Press the Finish key

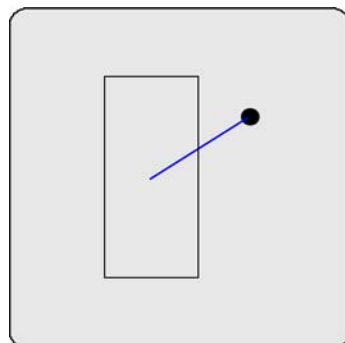

The line will be constructed to the center of the rectangle.

**Lines constructed from a point and an arc**

Up to three line constructions can be made from a point and an arc:

- Two point line:  
The line from the point to the center of the arc
- Tangent line 1:  
The line from the point to the first tangent of the arc
- Tangent line 2:  
The line from the point to the second tangent of the arc

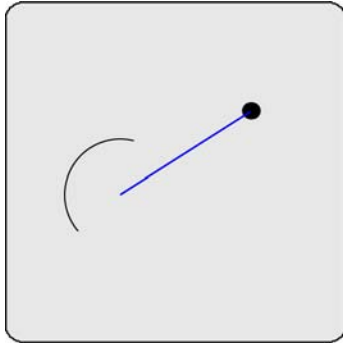

*Two point line*

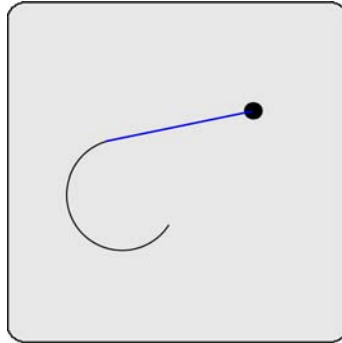

*Tangent line 1*

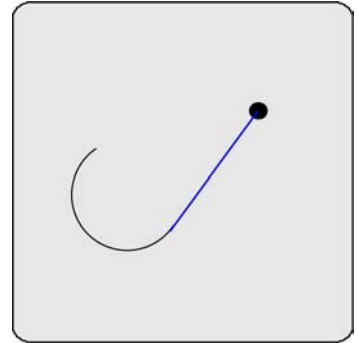

*Tangent line 2*

To construct a line from a point and an arc:

- 1 Touch the Measure line icon
- 2 Touch the point feature
- 3 Press the Enter key
- 4 Touch the arc feature
- 5 Press the Enter key
- 6 Press the Finish key

The two point line will be constructed. Alternative line constructions can be selected from the drop-down menu in the DRO window.

**Lines constructed from two lines**

Up to three line constructions can be made from two lines:

- Bisector line 1:  
Bisects the acute angle between the two lines
- Bisector line 2:  
Bisects the obtuse angle between the two lines
- Gage line:  
The line of a specified length perpendicular to bisector 1  
(The user will be prompted for the length)

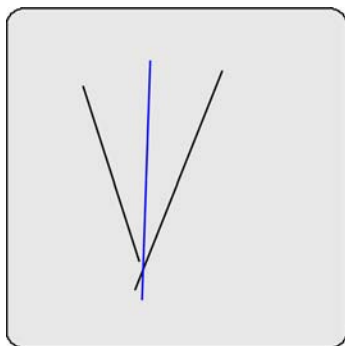

*Bisector line 1*

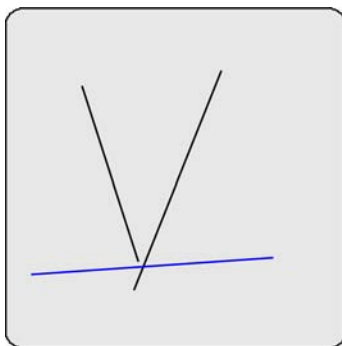

*Bisector line 2*

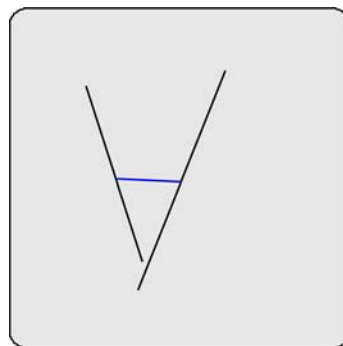

*Gage line*

To construct a line from two lines:

- 1 Touch the Measure line icon
- 2 Touch the first line feature
- 3 Press the Enter key
- 4 Touch the second line feature
- 5 Press the Enter key
- 6 Press the Finish key

The bisector 1 line will be constructed. Alternative line constructions can be selected from the drop-down menu in the DRO window.

**Line constructed from a line and a distance**

A line feature will be constructed and offset from a parent line feature by a parent distance feature.

To construct a line from a line and a distance:

- 1 Touch the Measure Line icon
- 2 Touch the line feature
- 3 Press the Enter key
- 4 Touch the distance feature
- 5 Press the Enter key
- 6 Press the Finish key

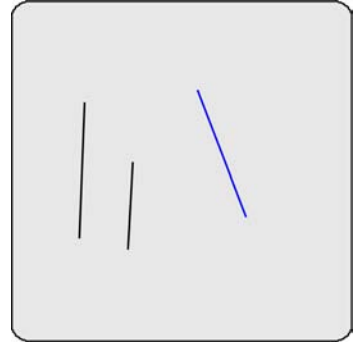

An offset line feature will be constructed.

**Lines constructed from a line and a circle**

Two line constructions can be made from a line and a circle:

- Perpendicular line:  
The line from the center of the circle, to the line, perpendicular to the line
- Parallel line:  
The line through the center of the circle, parallel to the line

To construct a line from a line and a circle:

- 1 Touch the Measure Line icon
- 2 Touch the line feature
- 3 Press the Enter key
- 4 Touch the circle feature
- 5 Press the Enter key
- 6 Press the Finish key

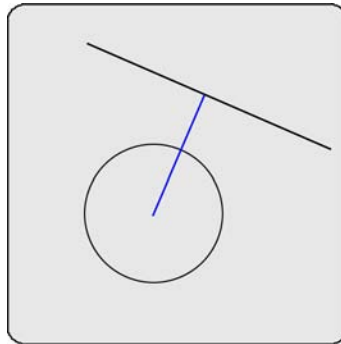

*Perpendicular line*

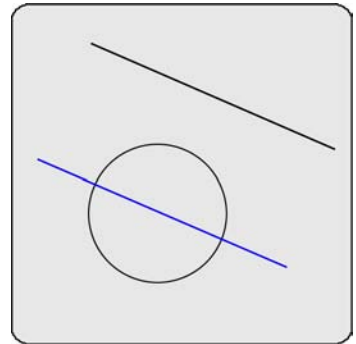

*Parallel line*

The perpendicular line will be constructed. Alternative line constructions can be selected from the drop-down menu in the DRO window.

**Lines constructed from a line and a slot**

The new line will be constructed from the center of the slot to the line, perpendicular to the line.

To construct a line from a line and a slot:

- 1 Touch the Measure Line icon
- 2 Touch the line feature
- 3 Press the Enter key
- 4 Touch the slot feature
- 5 Press the Enter key
- 6 Press the Finish key

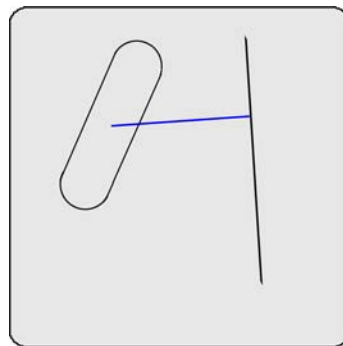

The perpendicular line will be constructed.

**Lines constructed from a line and an arc**

Two line constructions can be made from a line and an arc:

- Perpendicular line:  
The line from the center of the arc, to the line, perpendicular to the line
- Parallel line:  
The line through the center of the arc, parallel to the line

To construct a line from a line and a arc:

- 1 Touch the Measure Line icon
- 2 Touch the line feature
- 3 Press the Enter key
- 4 Touch the arc feature
- 5 Press the Enter key
- 6 Press the Finish key

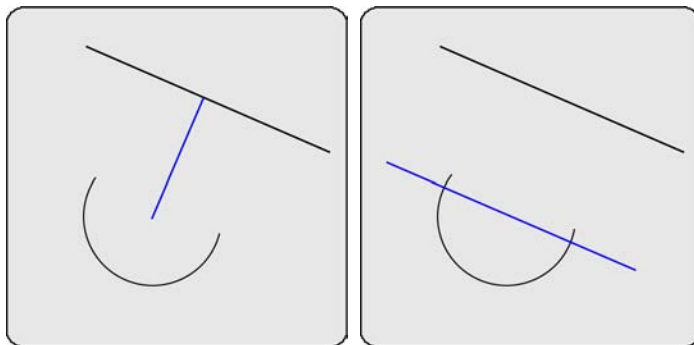

The perpendicular line will be constructed. The alternative parallel line construction can be selected from the drop-down menu in the DRO window.



**Line constructed from a line and an angle**

The line will be constructed and rotated counterclockwise the amount equal to the parent angle.

To construct a line from a line and an angle:

- 1 Touch the Measure Line icon
- 2 Touch the line feature
- 3 Press the Enter key
- 4 Touch the angle feature
- 5 Press the Enter key
- 6 Press the Finish key

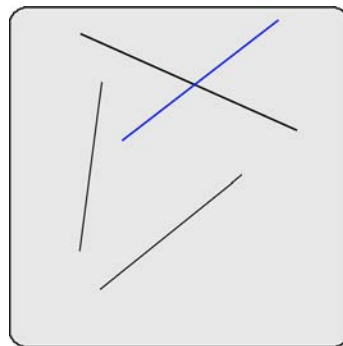

The rotated line will be constructed.

**Lines constructed from a line and a rectangle**

The new line will be constructed from the center of the rectangle to the line, perpendicular to the line.

To construct a line from a line and a rectangle:

- 1 Touch the Measure Line icon
- 2 Touch the line feature
- 3 Press the Enter key
- 4 Touch the rectangle feature
- 5 Press the Enter key
- 6 Press the Finish key

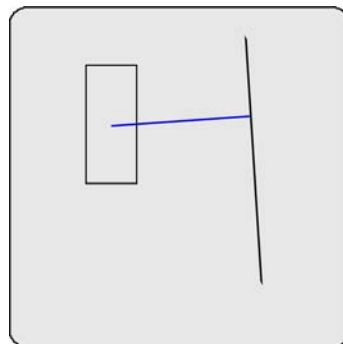

The perpendicular line will be constructed.

**Lines constructed from two circles**

Up to three line constructions can be made from two circles:

- Two point line:  
The line between the two circle centers
- Tangent line 1:  
The first line tangent to both circles on the same side
- Tangent line 2:  
The second line tangent to both circles on the opposite side

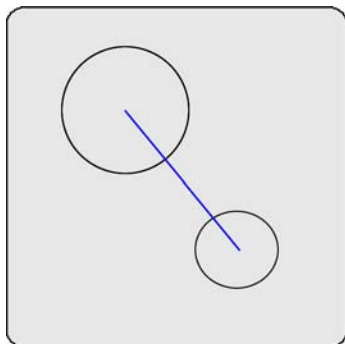

*Two point line*

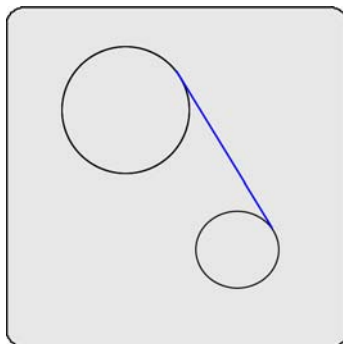

*Tangent line 1*

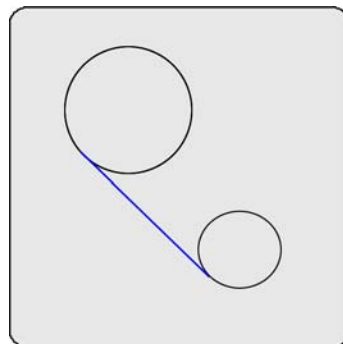

*Tangent line 2*

To construct a line between two circles:

- 1 Touch the Measure line icon
- 2 Touch the first circle feature
- 3 Press the Enter key
- 4 Touch the second circle feature
- 5 Press the Enter key
- 6 Press the Finish key

The two point line will be constructed. Alternative line constructions can be selected from the drop-down menu in the DRO window.

**Lines constructed from a circle and an arc**

Up to three line constructions can be made from a circle to an arc:

- Two point line:  
The line between the circle and arc centers
- Tangent line 1:  
The first line tangent to the circle and arc on the same side
- Tangent line 2:  
The second line tangent to the circle and arc on the opposite side

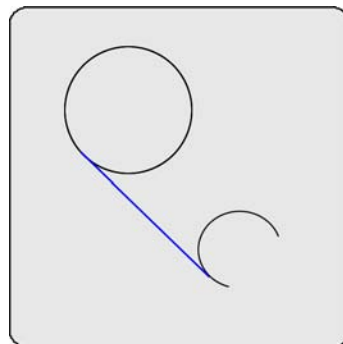
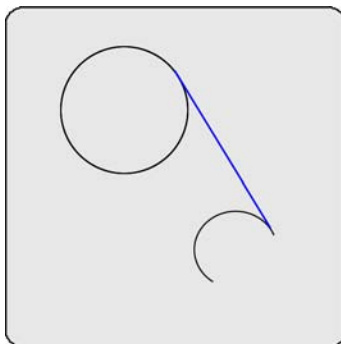
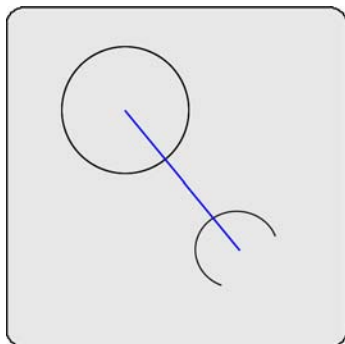

To construct a line between a circle and an arc:

- 1 Touch the Measure line icon
- 2 Touch the circle feature
- 3 Press the Enter key
- 4 Touch the arc feature
- 5 Press the Enter key
- 6 Press the Finish key

The two point line will be constructed. Alternative line constructions can be selected from the drop-down menu in the DRO window.

**Lines constructed from a circle and a slot**

The line feature will be constructed from the center of the circle to the center of the slot.

To construct a line from a circle and a slot:

- 1 Touch the Measure Line icon
- 2 Touch the circle feature
- 3 Press the Enter key
- 4 Touch the slot feature
- 5 Press the Enter key
- 6 Press the Finish key

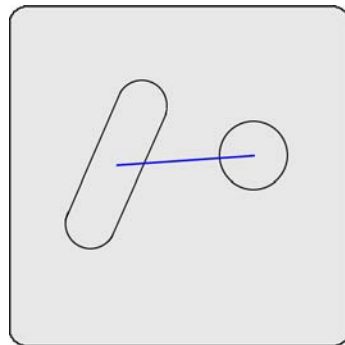

The center to center line will be constructed.

**Line constructed from a slot**

The line feature will be constructed from the arc center at one end of the slot to the arc center at the other end.

To construct a line from a slot:

- 1 Touch the Measure Line icon
- 2 Touch the slot feature
- 3 Press the Enter key
- 4 Press the Finish key

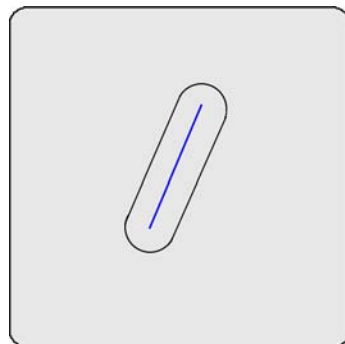

The center line of the slot will be constructed.

**Line constructed from two slots**

The line feature will be constructed from the center of one slot to the center of the other.

To construct a line from two slots:

- 1 Touch the Measure Line icon
- 2 Touch the first slot feature
- 3 Press the Enter key
- 4 Touch the second slot feature
- 5 Press the Enter key
- 6 Press the Finish key

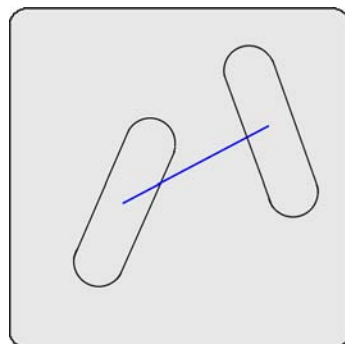

The line will be constructed between the two slots.

**Lines constructed from a circle and a rectangle**

The line feature will be constructed from the center of the circle to the center of the rectangle.

To construct a line from a circle and a rectangle:

- 1 Touch the Measure Line icon
- 2 Touch the circle feature
- 3 Press the Enter key
- 4 Touch the rectangle feature
- 5 Press the Enter key
- 6 Press the Finish key

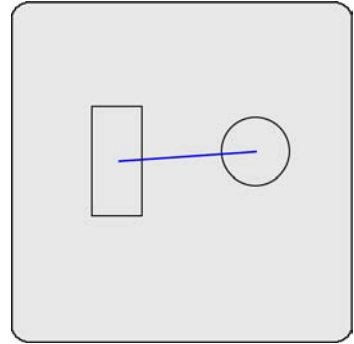

The center to center line will be constructed.

**Lines constructed from a slot and an arc**

The line feature will be constructed from the center of the slot to the center of the arc.

To construct a line from a slot and a arc:

- 1 Touch the Measure Line icon
- 2 Touch the slot feature
- 3 Press the Enter key
- 4 Touch the arc feature
- 5 Press the Enter key
- 6 Press the Finish key

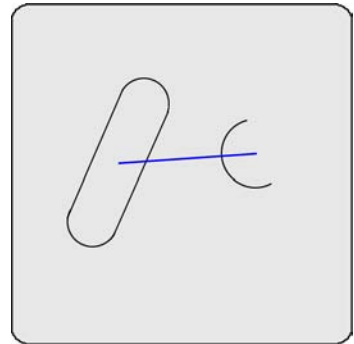

The center to center line will be constructed.

**Lines constructed from a rectangle and an arc**

The line feature will be constructed from the center of the rectangle to the center of the arc.

To construct a line from a rectangle and an arc:

- 1 Touch the Measure Line icon
- 2 Touch the rectangle feature
- 3 Press the Enter key
- 4 Touch the arc feature
- 5 Press the Enter key
- 6 Press the Finish key

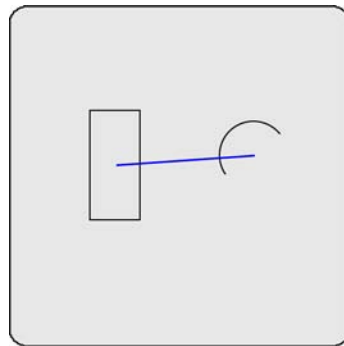

The center to center line will be constructed.

**Lines constructed from a slot and a rectangle**

The line feature will be constructed from the center of the slot to the center of the rectangle.

To construct a line from a slot and a rectangle:

- 1 Touch the Measure Line icon
- 2 Touch the slot feature
- 3 Press the Enter key
- 4 Touch the rectangle feature
- 5 Press the Enter key
- 6 Press the Finish key

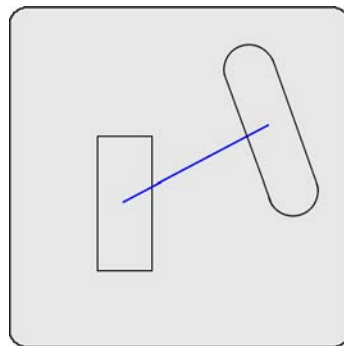

The center to center line will be constructed.

**Lines constructed between two rectangles**

The line feature will be constructed from the center of one rectangle to the center of the other.

To construct a line between two rectangles:

- 1 Touch the Measure Line icon
- 2 Touch the first rectangle feature
- 3 Press the Enter key
- 4 Touch the second rectangle feature
- 5 Press the Enter key
- 6 Press the Finish key

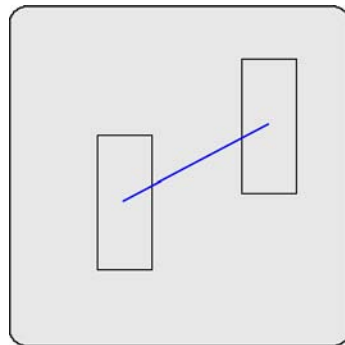

The center to center line will be constructed.

**Line constructed from two arcs**

Up to three line constructions can be made from two arcs:

- Two point line:  
The line between the two arc centers
- Tangent line 1:  
The first line tangent to both arcs on the same side
- Tangent line 2:  
The second line tangent to both arcs on the opposite side

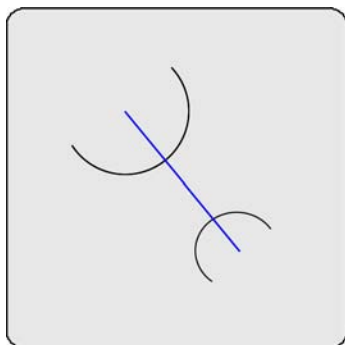

*Two point line*

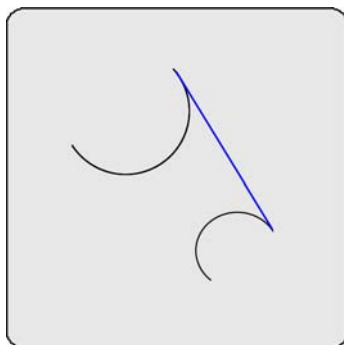

*Tangent line 1*

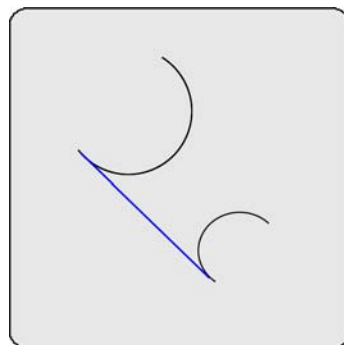

*Tangent line 2*

To construct a line between two arcs:

- 1 Touch the Measure Line icon
- 2 Touch the first arc feature
- 3 Press the Enter key
- 4 Touch the second arc feature
- 5 Press the Enter key
- 6 Press the Finish key

The two point line will be constructed. Alternative line constructions can be selected from the drop-down menu in the DRO window.



**Line constructed from a rectangle**

The line feature will be constructed from the radius center at one end of the rectangle to the radius center at the other end.

To construct a line from a slot:

- 1 Touch the Measure Line icon
- 2 Touch the rectangle feature
- 3 Press the Enter key
- 4 Press the Finish key

The center line of the rectangle will be constructed.

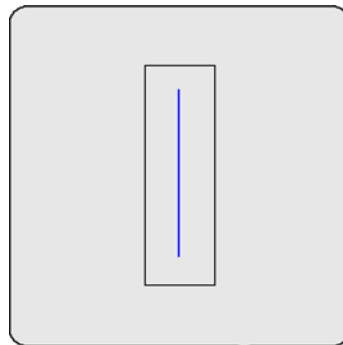
**Line constructed from multiple features**

The best fit line through the center of multiple features can be constructed from any combination and any number of points, slots, circles, and arcs.

To construct a line from multiple features:

- 1 Touch the Measure Line icon
- 2 Touch a feature
- 3 Press the Enter key
- 4 Repeat steps 2 and 3 for all features
- 5 Press the Finish key

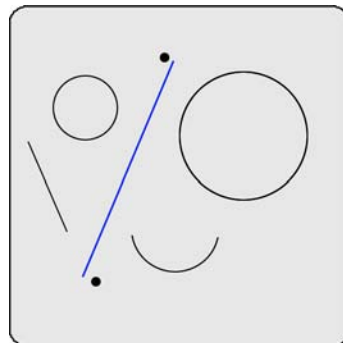

The best fit line through the entire collection of features will be constructed.

## ***Distance constructions***

Distances can be constructed from:

- Points
- Lines
- Distances
- Circles
- Arcs
- Slots

### **Distance constructed from a distance**

A duplicate feature can be useful when it becomes desirable to perform new operations with the original while retaining a copy. To construct a distance from an existing distance:

- 1 Touch the Measure Distance icon
- 2 Touch the desired distance
- 3 Press the Enter key
- 4 Press the Finish key

The new distance feature will be constructed over the original distance.

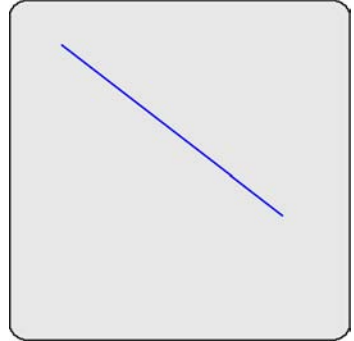

### **Distances constructed from two points**

The distance feature will be constructed between the two points.

To construct a distance from two points:

- 1 Touch the Measure Distance icon
- 2 Touch the first point Feature
- 3 Press the Enter key
- 4 Touch the second point Feature
- 5 Press the Enter key
- 6 Press the Finish key

The new distance feature will be constructed between the two points.

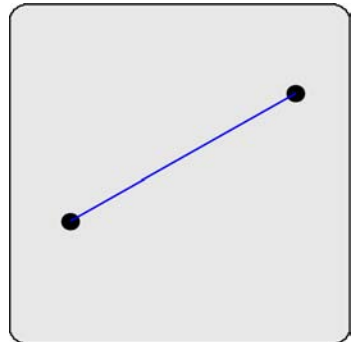

### Distances constructed from a point and a line

The distance feature will be constructed from the point to the line perpendicular to the line, or perpendicular to the extended virtual line if the line feature is short.

To construct a distance from a point and a line:

- 1 Touch the Measure Distance icon
- 2 Touch the point feature
- 3 Press the Enter key
- 4 Touch the line feature
- 5 Press the Enter key
- 6 Press the Finish key

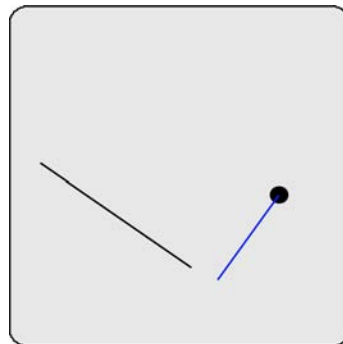
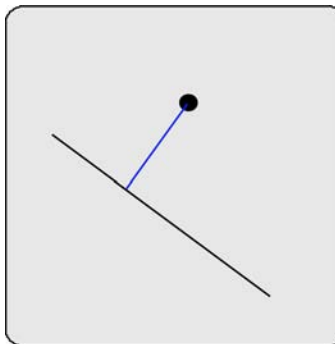

The new distance feature will be constructed.

### Distances constructed from a point and a rectangle

The distance feature will be constructed from the point to the center of the rectangle.

To construct a distance from a point and a rectangle:

- 1 Touch the Measure Distance icon
- 2 Touch the point feature
- 3 Press the Enter key
- 4 Touch the rectangle feature
- 5 Press the Enter key
- 6 Press the Finish key

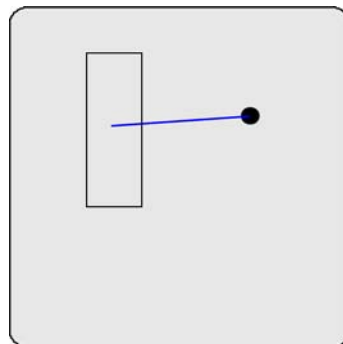

The new distance feature will be constructed.

**Distances constructed from a point and a circle**

Up to three distance constructions can be made from a point to a circle:

- Distance between features:  
The distance between the point and circle center
- Nearest distance:  
The distance between the point and nearest circle circumference
- Farthest distance:  
The distance between the point and farthest circle circumference

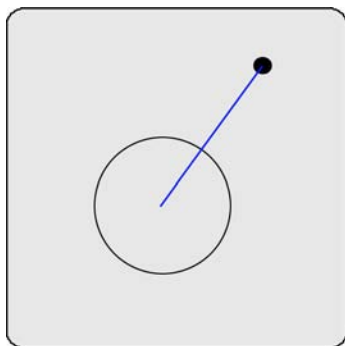

*Distance between features*

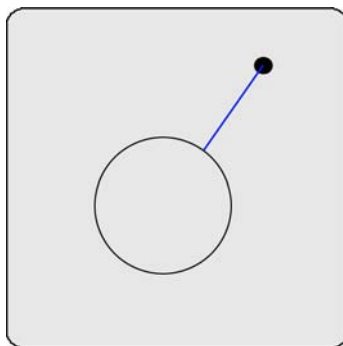

*Nearest distance*

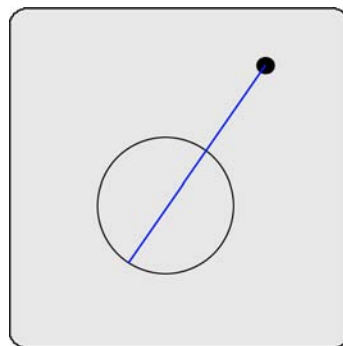

*Farthest distance*

To construct a distance between a point and a circle:

- 1 Touch the Measure Distance icon
- 2 Touch the point feature
- 3 Press the Enter key
- 4 Touch the circle feature
- 5 Press the Enter key
- 6 Press the Finish key

The distance between the point and circle center will be constructed. Alternative distance constructions can be selected from the drop-down menu in the DRO window.

**Distance constructed from a point and a slot**

The distance feature will be constructed between the point and the center of the slot.

To construct a distance from a point to a slot:

- 1 Touch the Measure Distance icon
- 2 Touch the point Feature
- 3 Press the Enter key
- 4 Touch the slot Feature
- 5 Press the Enter key
- 6 Press the Finish key

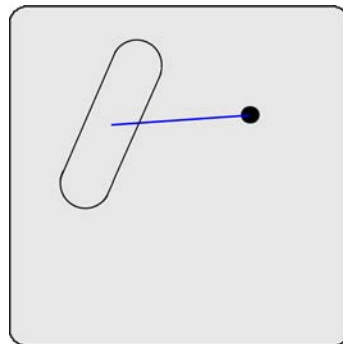

The new distance feature will be constructed between the point and the slot.

**Distances constructed from a point and an arc**

Up to three distance constructions can be made from a point to an arc:

- Distance between features:  
The distance between the point and arc center
- Nearest distance:  
The distance between the point and nearest arc circumference
- Farthest distance:  
The distance between the point and farthest arc circumference

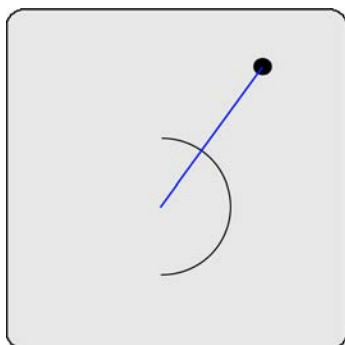

*Distance between features*

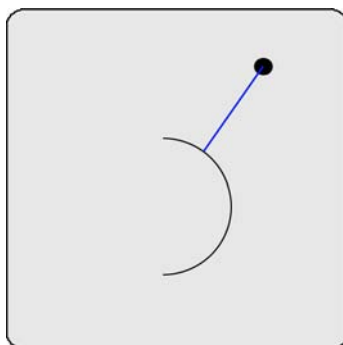

*Nearest distance*

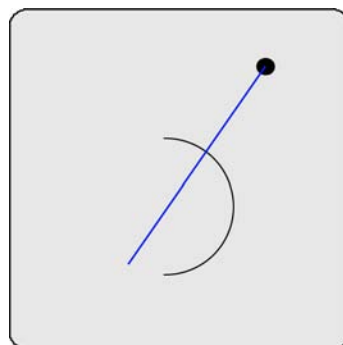

*Farthest distance*

To construct a distance between a point and a arc:

- 1 Touch the Measure Distance icon
- 2 Touch the point feature
- 3 Press the Enter key
- 4 Touch the arc feature
- 5 Press the Enter key
- 6 Press the Finish key

The distance between the point and arc center will be constructed. Alternative distance constructions can be selected from the drop-down menu in the DRO window.

**Distance constructed from a line**

The length-of-axis distance feature will be constructed from a parent line feature.

To construct a distance from a line:

- 1 Touch the Measure Distance icon
- 2 Touch the line Feature
- 3 Press the Enter key
- 4 Press the Finish key

The new distance feature will be constructed over the line.

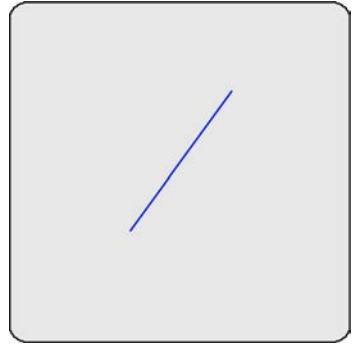
**Distance constructed from a line and a rectangle**

The distance feature will be constructed between the center of the line and the center of the rectangle.

To construct a distance from a line to a rectangle:

- 1 Touch the Measure Distance icon
- 2 Touch the line Feature
- 3 Press the Enter key
- 4 Touch the rectangle Feature
- 5 Press the Enter key
- 6 Press the Finish key

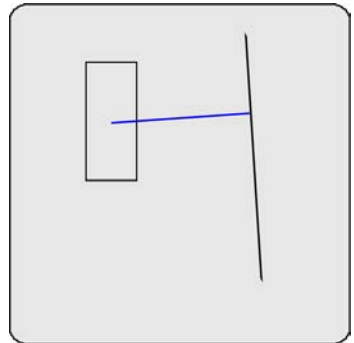

The new distance feature will be constructed between the two centers.

**Distances constructed from two lines**

Up to three distance constructions can be made from two lines:

- Center distance:  
The perpendicular distance from the first line in the features list to the center of the second
- Min distance:  
The perpendicular distance from the first line in the features list to the nearest point of the second
- Max distance:  
The perpendicular distance from the first line in the features list to the farthest point of the second

Distances from virtual line extensions will be shown if the first line in the features list is not long.

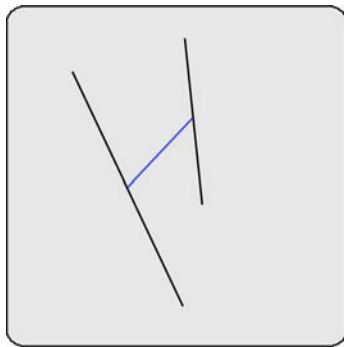

*Center distance*

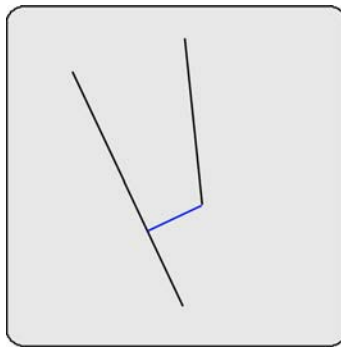

*Min distance*

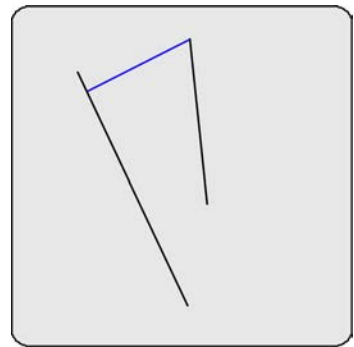

*Max distance*

To construct a distance between two lines:

- 1 Touch the Measure Distance icon
- 2 Touch the first line feature
- 3 Press the Enter key
- 4 Touch the second line feature
- 5 Press the Enter key
- 6 Press the Finish key

The center distance will be constructed. Alternative distance constructions can be selected from the drop-down menu in the DRO window.



### Distances constructed from a line and a circle

Up to three distance constructions can be made from a line and a circle:

- Center distance:  
The perpendicular distance from the line to the center of the circle
- Min distance:  
The perpendicular distance from the line to the nearest point of the circle
- Max distance:  
The perpendicular distance from the line to the farthest point of the circle

Distances from virtual line extensions will be shown if the line is not long.

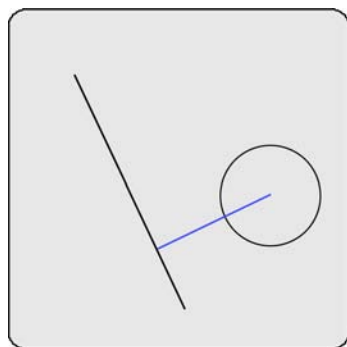

*Center distance*

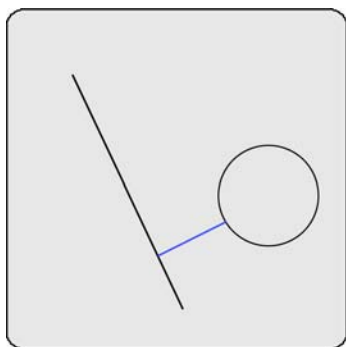

*Min distance*

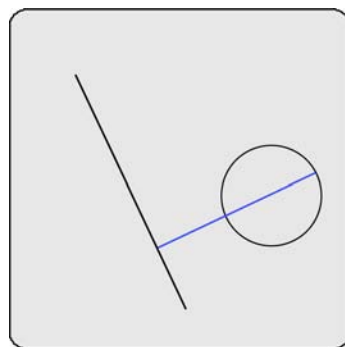

*Max distance*

To construct a distance between a line and a circle:

- 1 Touch the Measure Distance icon
- 2 Touch the line feature
- 3 Press the Enter key
- 4 Touch the circle feature
- 5 Press the Enter key
- 6 Press the Finish key

The center distance will be constructed. Alternative distance constructions can be selected from the drop-down menu in the DRO window.

**Distances constructed from a line and an arc**

Up to three distance constructions can be made from a line and an arc:

- Center distance:  
The perpendicular distance from the line to the center of the arc
- Min distance:  
The perpendicular distance from the line to the nearest point of the arc
- Max distance:  
The perpendicular distance from the line to the farthest point of the arc

Distances from virtual line extensions will be shown if the line is not long.

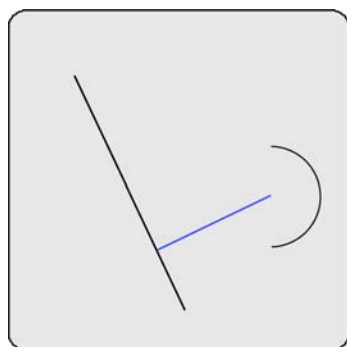

*Center distance*

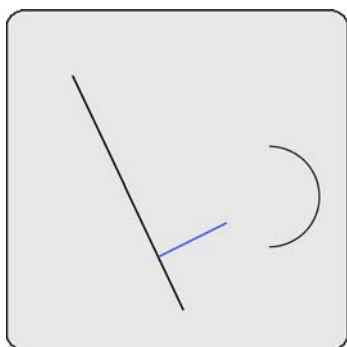

*Min distance*

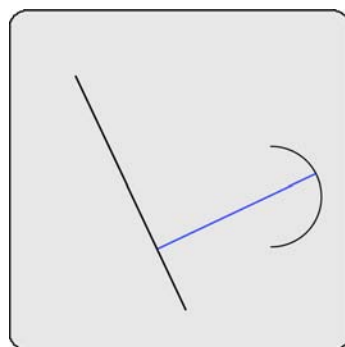

*Max distance*

To construct the distance between a line and an arc:

- 1 Touch the Measure Distance icon
- 2 Touch the line feature
- 3 Press the Enter key
- 4 Touch the arc feature
- 5 Press the Enter key
- 6 Press the Finish key

The center distance will be constructed. Alternative distance constructions can be selected from the drop-down menu in the DRO window.

**Distance constructed from a line and a slot**

The distance feature will be constructed from the center of the slot perpendicular to the line.

To construct a distance from a line and a slot:

- 1 Touch the Measure Distance icon
- 2 Touch the line Feature
- 3 Press the Enter key
- 4 Touch the slot Feature
- 5 Press the Enter key
- 6 Press the Finish key

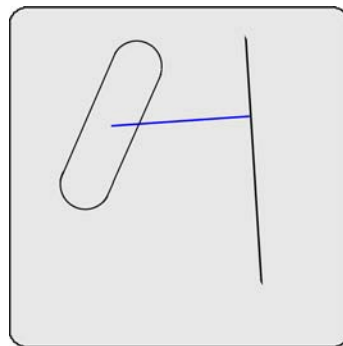

The distance feature will be constructed between the line and slot. Distances from virtual line extensions will be shown if the line is not long.

**Distance constructed from two distances**

The sum-of-distances feature will be constructed from two distance features.

To construct a distance from two distance features:

- 1 Touch the Measure Distance icon
- 2 Touch the first distance Feature
- 3 Press the Enter key
- 4 Touch the second distance Feature
- 5 Press the Enter key
- 6 Press the Finish key

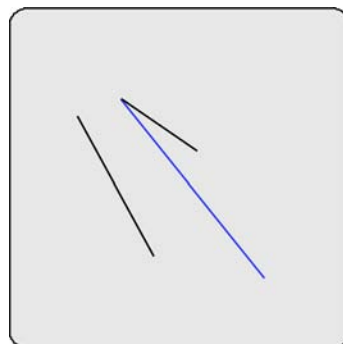

The distance feature will be constructed between the two distance features.

**Distances constructed from two circles**

Up to three distance constructions can be made from two circles:

- Center distance:  
The distance from the center of one circle to the center of the other
- Min distance:  
The minimum distance between the two circle circumferences
- Max distance:  
The maximum distance between the two circle circumferences

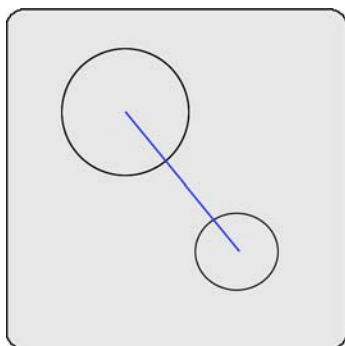

**Center distance**

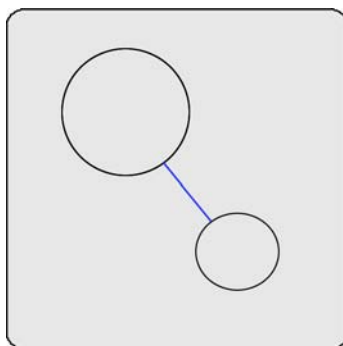

**Min distance**

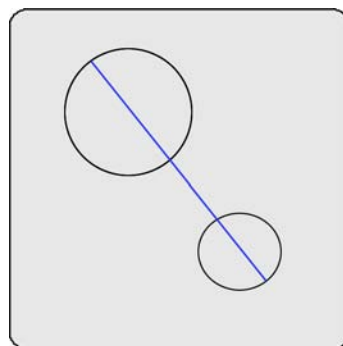

**Max distance**

To construct the distance between two circles:

- 1 Touch the Measure Distance icon
- 2 Touch the first circle feature
- 3 Press the Enter key
- 4 Touch the second circle feature
- 5 Press the Enter key
- 6 Press the Finish key

The center distance will be constructed. Alternative distance constructions can be selected from the drop-down menu in the DRO window.

**Distances constructed from a slot and a circle**

The distance feature will be constructed between the centers of the slot and the circle.

To construct a distance from a slot and a circle:

- 1 Touch the Measure Distance icon
- 2 Touch the slot Feature
- 3 Press the Enter key
- 4 Touch the circle Feature
- 5 Press the Enter key
- 6 Press the Finish key

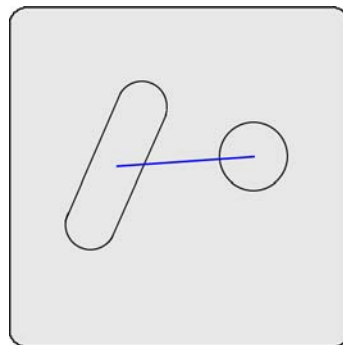

The distance feature will be constructed between the slot and the circle.

**Distances constructed from a rectangle and a circle**

The distance feature will be constructed between the centers of the rectangle and the circle.

To construct a distance from a rectangle and a circle:

- 1 Touch the Measure Distance icon
- 2 Touch the rectangle Feature
- 3 Press the Enter key
- 4 Touch the circle Feature
- 5 Press the Enter key
- 6 Press the Finish key

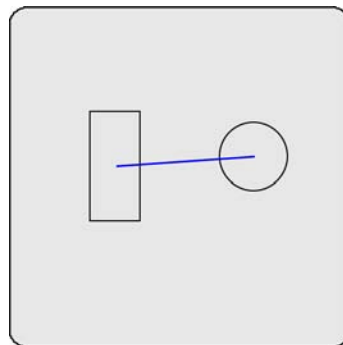

The distance feature will be constructed between the rectangle and the circle.

**Distances constructed from an arc and a circle**

Up to three distance constructions can be made from an arc and a circle:

- Center distance:  
The distance from the center of the circle to the center of the arc
- Min distance:  
The minimum distance between the arc and circle circumferences
- Max distance:  
The maximum distance between the arc and circle circumferences

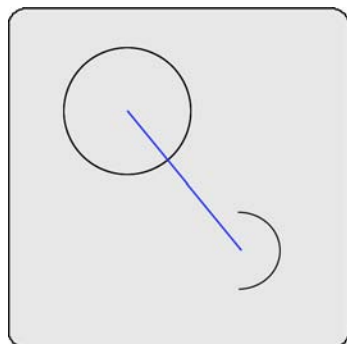

*Center distance*

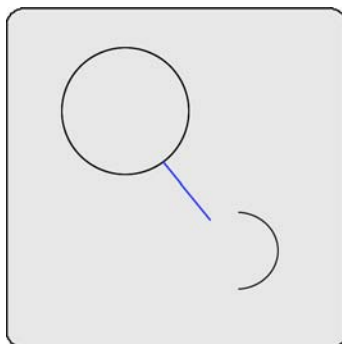

*Min distance*

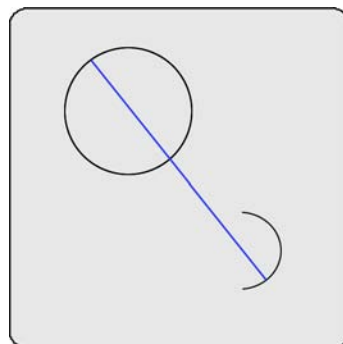

*Max distance*

To construct the distance between an arc and a circle:

- 1 Touch the Measure Distance icon
- 2 Touch the arc feature
- 3 Press the Enter key
- 4 Touch the circle feature
- 5 Press the Enter key
- 6 Press the Finish key

The center distance will be constructed. Alternative distance constructions can be selected from the drop-down menu in the DRO window.

**Distance constructed from two slots**

The distance feature will be constructed between the centers of two slots.

To construct a distance between two slots:

- 1 Touch the Measure Distance icon
- 2 Touch the first slot Feature
- 3 Press the Enter key
- 4 Touch the second slot Feature
- 5 Press the Enter key
- 6 Press the Finish key

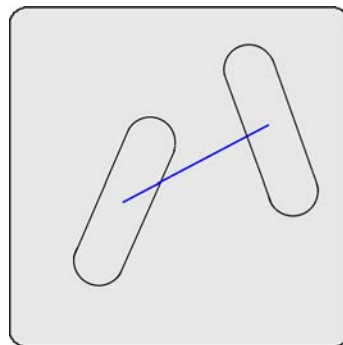

The distance feature will be constructed between the two slots.

**Distances constructed from a slot and an arc**

The distance feature will be constructed between the centers of the slot and the arc.

To construct a distance from a slot and an arc:

- 1 Touch the Measure Distance icon
- 2 Touch the slot Feature
- 3 Press the Enter key
- 4 Touch the arc Feature
- 5 Press the Enter key
- 6 Press the Finish key

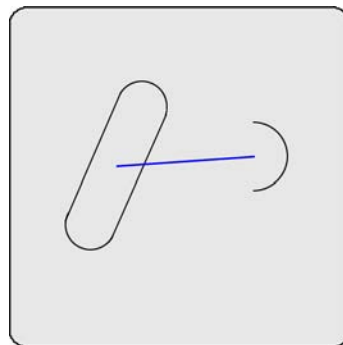

The distance feature will be constructed between the slot and the arc.

**Distances constructed from a rectangle and an arc**

The distance feature will be constructed between the centers of the rectangle and the arc.

To construct a distance from a rectangle and an arc:

- 1 Touch the Measure Distance icon
- 2 Touch the rectangle Feature
- 3 Press the Enter key
- 4 Touch the arc Feature
- 5 Press the Enter key
- 6 Press the Finish key

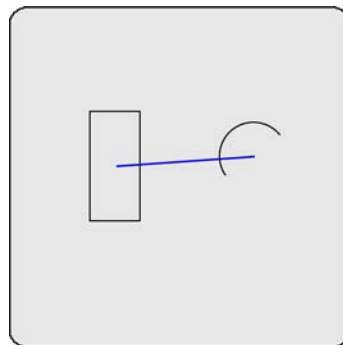

The distance feature will be constructed between the rectangle and the arc.

**Distances constructed from a slot and a rectangle**

The distance feature will be constructed between the centers of a slot and a rectangle.

To construct a distance from a slot and a rectangle:

- 1 Touch the Measure Distance icon
- 2 Touch the slot Feature
- 3 Press the Enter key
- 4 Touch the rectangle Feature
- 5 Press the Enter key
- 6 Press the Finish key

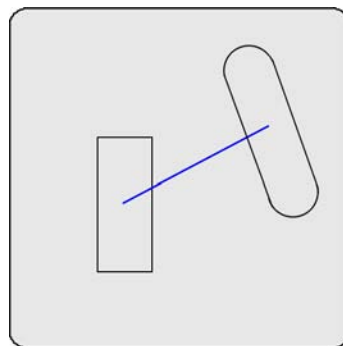

The distance feature will be constructed between the slot and the rectangle.



**Distances constructed between two rectangles**

The distance feature will be constructed between the centers of two rectangles.

To construct a distance between two rectangles:

- 1 Touch the Measure Distance icon
- 2 Touch the first rectangle Feature
- 3 Press the Enter key
- 4 Touch the second rectangle Feature
- 5 Press the Enter key
- 6 Press the Finish key

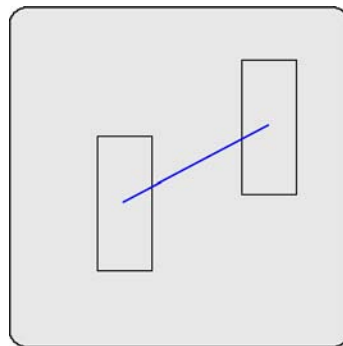

The distance feature will be constructed between the two rectangles.

**Distances constructed from two arcs**

Up to three different distance constructions can be made from two arcs:

- Center distance:  
The distance from the center of one arc to the center of the other
- Min distance:  
The minimum distance between the two arc circumferences
- Max distance:  
The maximum distance between the two arc circumferences

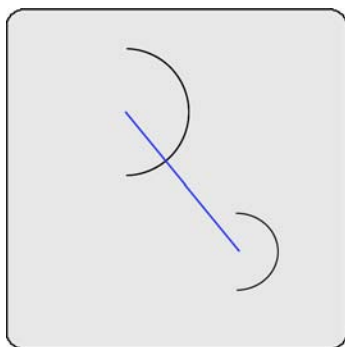

*Center distance*

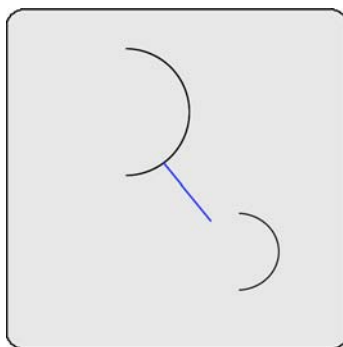

*Min distance*

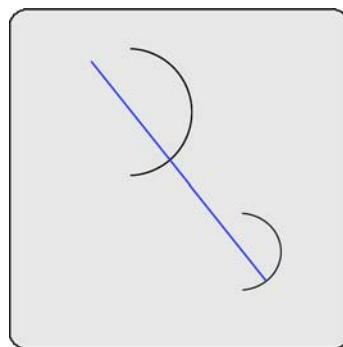

*Max distance*

To construct the distance between two arcs:

- 1 Touch the Measure Distance icon
- 2 Touch the first arc feature
- 3 Press the Enter key
- 4 Touch the second arc feature
- 5 Press the Enter key
- 6 Press the Finish key

The center distance will be constructed. Alternative distance constructions can be selected from the drop-down menu in the DRO window.

## ***Circle constructions***

Circles can be constructed from:

- Points
- Lines
- Circles
- Slots
- Distances
- Arcs

### **Circle constructed from a circle**

A duplicate feature can be useful when it becomes desirable to perform new operations with the original while retaining a copy.

To construct a circle from an existing circle:

- 1 Touch the Measure Circle icon
- 2 Touch the desired circle
- 3 Press the Enter key
- 4 Press the Finish key

The new circle feature will be constructed over the original circle.

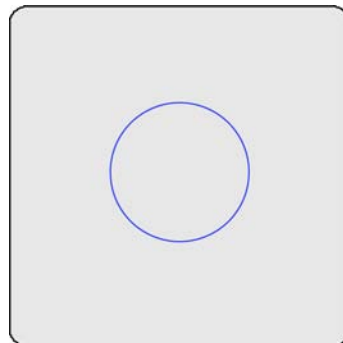

### **Circles constructed from two lines**

A wire gage circle will be constructed between the two lines. The user will be prompted for the circle radius.

To construct a circle from two lines:

- 1 Touch the Measure Circle icon
- 2 Touch the first line feature
- 3 Press the Enter key
- 4 Touch the second line feature
- 5 Press the Enter key
- 6 Press the Finish key

The wire gage circle will be constructed.

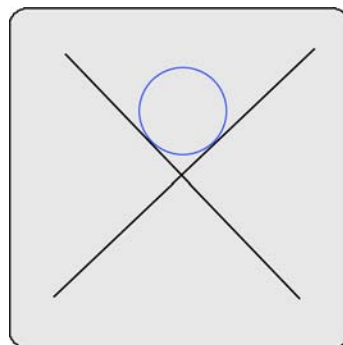

**Circle constructed from a circle and a distance**

An offset circle will be constructed from circle and distance parent features. A circle equal to the parent circle will be constructed, offset the amount equal to the parent distance.

To construct a circle from a circle and a distance:

- 1 Touch the Measure Circle icon
- 2 Touch the circle feature
- 3 Press the Enter key
- 4 Touch the distance feature
- 5 Press the Enter key
- 6 Press the Finish key

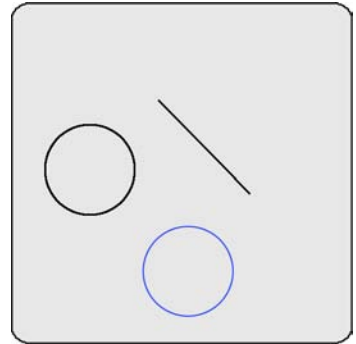

The offset circle will be constructed.

**Circle constructed from two circles**

The circle will be constructed as an average of the two parent positions and sizes.

To construct a circle from two circles:

- 1 Touch the Measure Circle icon
- 2 Touch the first circle feature
- 3 Press the Enter key
- 4 Touch the second circle feature
- 5 Press the Enter key
- 6 Press the Finish key

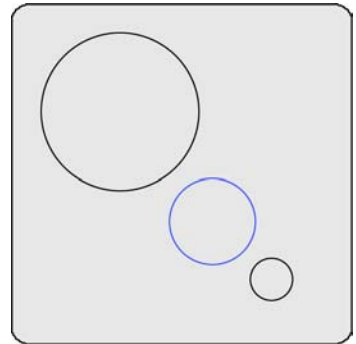

The average circle will be constructed.

### Circle constructed from multiple features

A circle feature can be constructed from any number of parent features. The parent features can be any combination of points, slots, arcs and circles. The center points of the parent features will be used to construct the new circle feature. When more than three parent features are used, the circle can be constructed using the fitting algorithm of the user's choice.

To construct a circle from multiple features:

- 1 Touch the Measure Circle icon
- 2 Touch a feature
- 3 Press the Enter key
- 4 Repeat steps 2 and 3 for all features
- 5 Press the Finish key

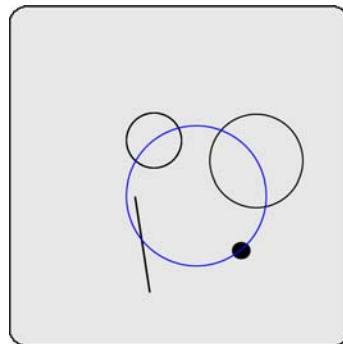

The best fit circle through the entire collection of features will be constructed.

## Arc constructions

Arcs can be constructed from:

- Points
- Lines
- Circles
- Slots
- Distances
- Arcs

### Arc constructed from an arc

A duplicate feature can be useful when it becomes desirable to perform new operations with the original while retaining a copy.

To construct an arc from an existing arc:

- 1 Touch the Measure Arc icon
- 2 Touch the desired arc
- 3 Press the Enter key
- 4 Press the Finish key

The new arc feature will be constructed over the original arc.

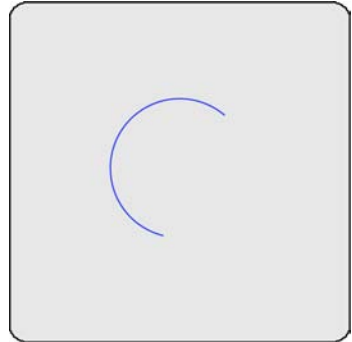

### Arc constructed from an arc and a distance

An offset arc will be constructed from arc and distance parent features. An arc equal to the parent arc will be constructed, offset the amount equal to the parent distance.

To construct an arc from an arc and a distance:

- 1 Touch the Measure Arc icon
- 2 Touch the arc feature
- 3 Press the Enter key
- 4 Touch the distance feature
- 5 Press the Enter key
- 6 Press the Finish key

The offset arc will be constructed.

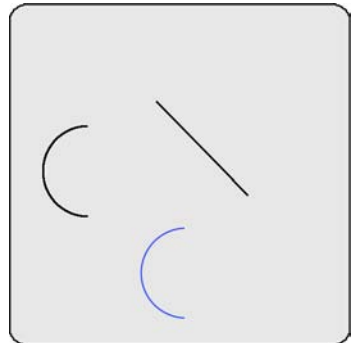

### Arc constructed from multiple features

An arc feature can be constructed from any number of parent features. The parent features can be any combination of points, slots, arcs and circles. The center points of the parent features will be used to construct the new arc feature. When more than three parent features are used, the circle can be constructed using the fitting algorithm of the user's choice.

To construct a arc from multiple features:

- 1 Touch the Measure Arc icon
- 2 Touch a feature
- 3 Press the Enter key
- 4 Repeat steps 2 and 3 for all features
- 5 Press the Finish key

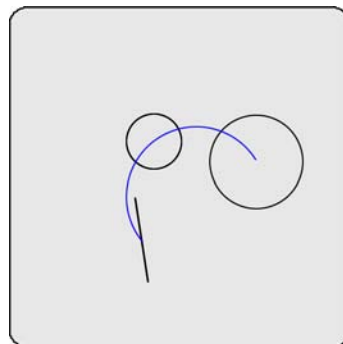

The best fit arc through the entire collection of features will be constructed.

## Angle constructions

Angles can be constructed from:

- An angle
- Two lines

### Angle constructed from an angle

A duplicate feature can be useful when it becomes desirable to perform new operations with the original while retaining a copy.

To construct an angle from an existing angle:

- 1 Touch the Measure Angle icon
- 2 Touch the desired angle
- 3 Press the Enter key
- 4 Press the Finish key

The new angle feature will be constructed over the original angle.

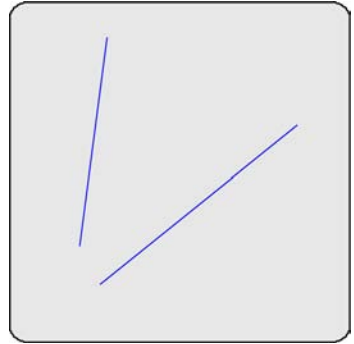



**Angle constructed from two lines**

Up to four angle constructions can be made from two lines:

- Interior angle:  
The angle included between the lines
- 180 minus:  
180 degrees minus the angle included between the lines
- 180 plus:  
180 degrees plus the angle included between the lines
- 360 minus:  
360 degrees minus the angle included between the lines

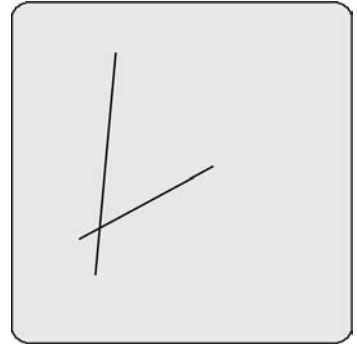
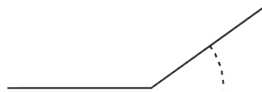
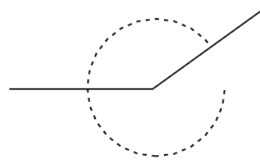
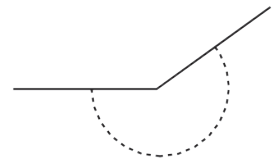
*Interior angle**180 minus**180 plus**360 minus*

To construct angles from two lines:

- 1 Touch the Measure Angle icon
- 2 Touch the first line feature
- 3 Press the Enter key
- 4 Touch the second line feature
- 5 Press the Enter key
- 6 Press the Finish key

The interior angle will be constructed. Alternative angle constructions can be selected from the drop-down menu in the DRO window.

## Creating features

Features can be created by entering information that describes feature size and position. Information can be entered in metric or English units of measure.

The following feature types can be created:

- Points
- Lines
- Distances
- Rectangles
- Circles
- Arcs
- Slots

### Creating a point

To create a point:

- 1 Touch the measure point icon, and then touch the data entry icon. The data entry box will be displayed.

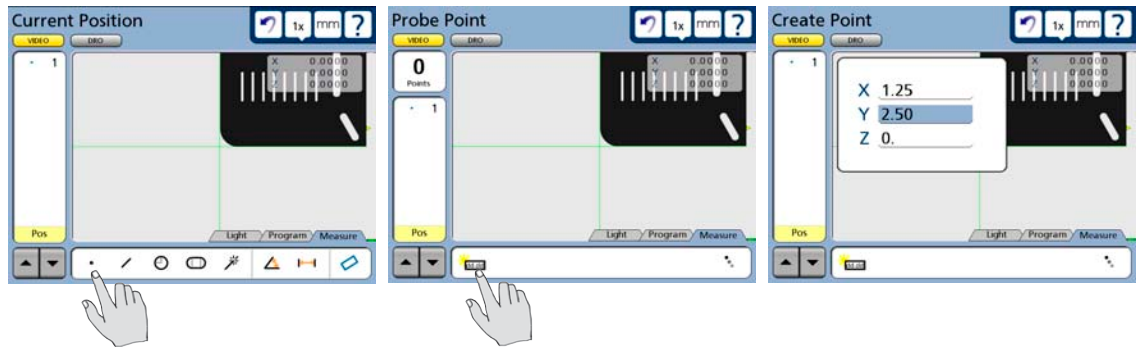

- 2 Enter the feature data in the fields provided and press Finish.

## Creating a line

To create a line:

- 1 Touch the measure line icon, and then touch the data entry icon. The data entry box will be displayed.

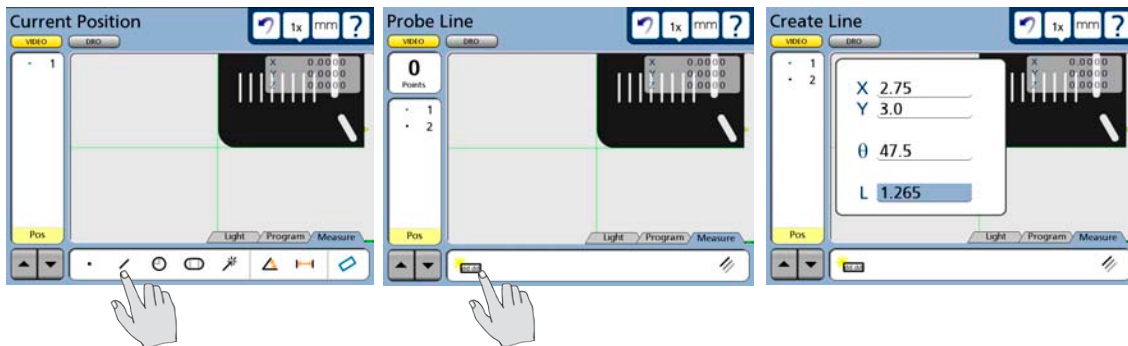

- 2 Enter the feature data in the fields provided and press Finish.

## Creating a circle

To create a circle:

- 1 Touch the measure circle icon, and then touch the data entry icon. The data entry box will be displayed.

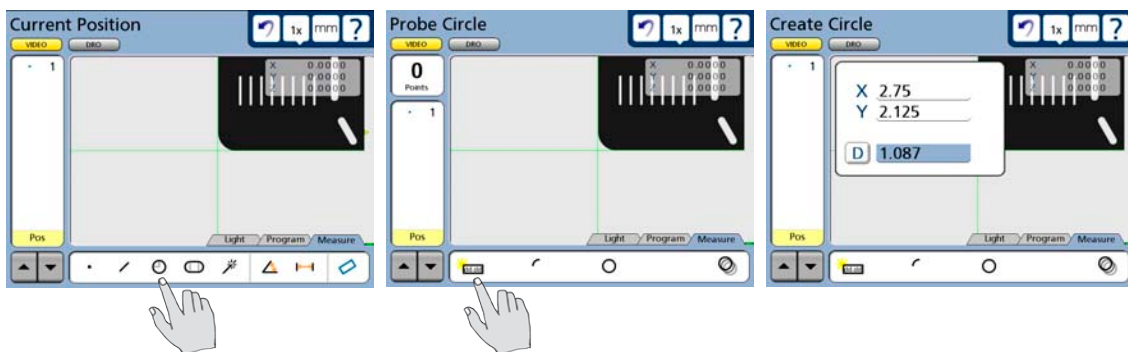

- 2 Enter the feature data in the fields provided and press Finish.

### Creating an arc

To create an arc:

- 1 Touch the measure circle icon, the measure arc icon and then touch the data entry icon. The data entry box will be displayed.

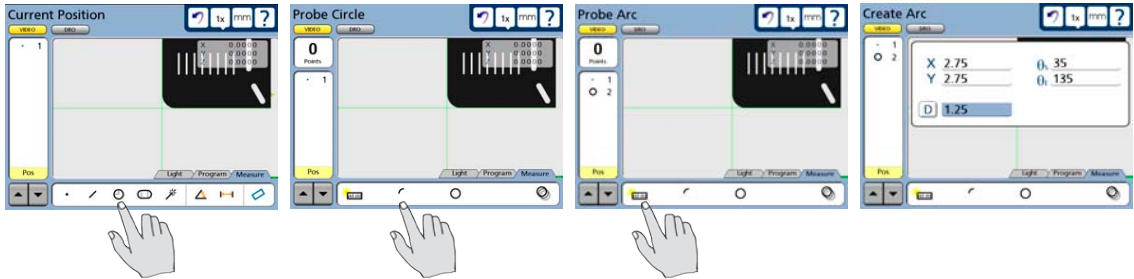

- 2 Enter the feature data in the fields provided and press Finish.

### Creating a slot

To create a slot:

- 1 Touch the measure slot icon, and then touch the data entry icon. The data entry box will be displayed.

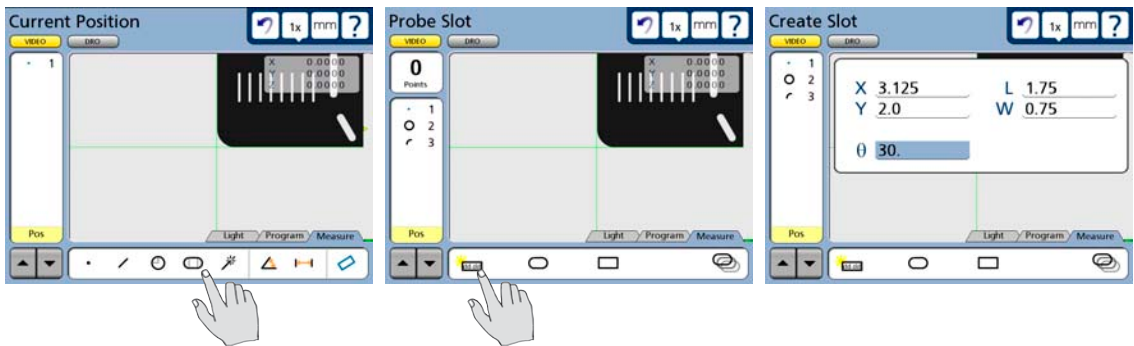

- 2 Enter the feature data in the fields provided and press Finish.

## Creating a rectangle

To create a rectangle:

- 1 Touch the measure slot icon, the measure rectangle icon and then touch the data entry icon. The data entry box will be displayed.

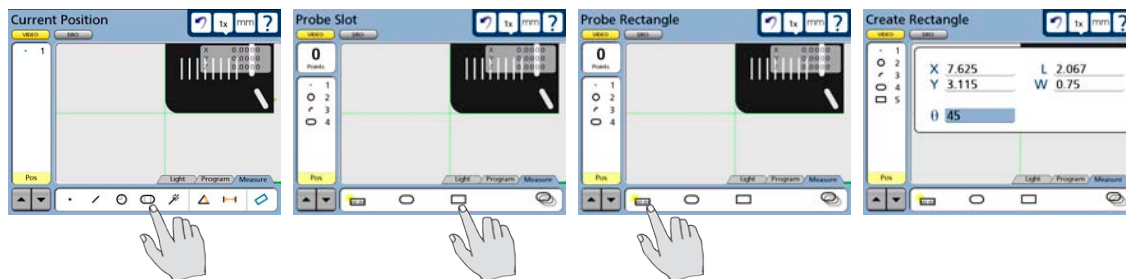

- 2 Enter the feature data in the fields provided and press Finish.

# Chapter 7: Tolerancing

Tolerances can easily be applied to position, size, orientation, form, runout and concentricity measurements using the tools found in the tolerance screens.



## CAUTION

Discrete point measuring machines estimate the size, position, orientation, and form of geometric features based on points probed. When parts are designed with critical tolerances, be sure that you have probed sufficient points to calculate a reliable estimate. For example, if you probe a circle with only three points, the circularity will be perfect and the circle will always pass a form tolerance test.



## CAUTION

The QC-300 uses a best fit algorithm to estimate the size, position, orientation and form of geometric features. While the best fit yields very useful information, the results do not necessarily reflect how well the parts will fit together and perform their function. For example, a hole diameter could be calculated as 10.000 mm but have poor form. In this case, a 9.9 mm pin might not fit in the 10.000 mm hole.



## NOTE

Tolerance calculations comply with the ASME Y14.5M-1994 standard except as noted in the tolerance section of Chapter 12: Reference Materials.

This chapter includes the following tolerance information:

Applying tolerances to features.....	141
Selecting a feature.....	141
Displaying the tolerance screen.....	141
Selecting a tolerance type.....	141
Selecting a specific tolerance.....	142
Entering nominal, limit or tolerance values.....	142
Omitting a tolerance category.....	143
Tolerance types.....	144
Bidirectional.....	144
True position.....	146
MMC/LMC (Material condition).....	147
Runout.....	149
Roundness.....	149
Concentricity.....	149
Straightness.....	149
Parallelism.....	150
Perpendicularity.....	150
Angle.....	150
Width.....	151

## Applying tolerances to features

Tolerances are applied to feature measurements using tolerance screens. The method of applying tolerances to features is diagrammed below and is nearly identical for all tolerance types.

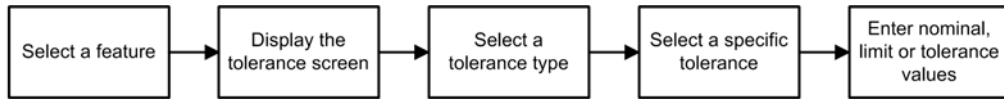

In the following example, a true position tolerance is applied to a circle feature.

### Selecting a feature

Touch the desired feature in the feature list to select it.

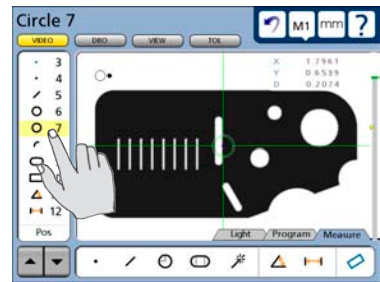

### Displaying the tolerance screen

Touch the Tol screen button to display the tolerance screen.

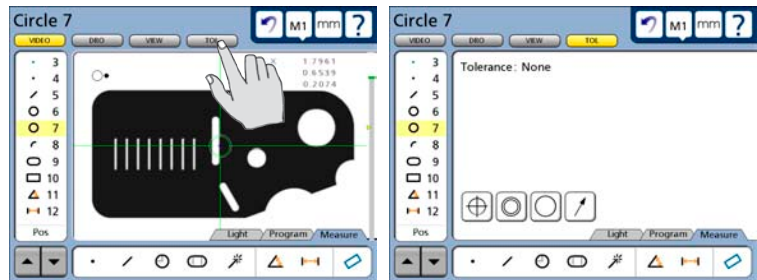

### Selecting a tolerance type

Touch the desired tolerance type button to select a tolerance type. In this example, the position tolerance type is selected.

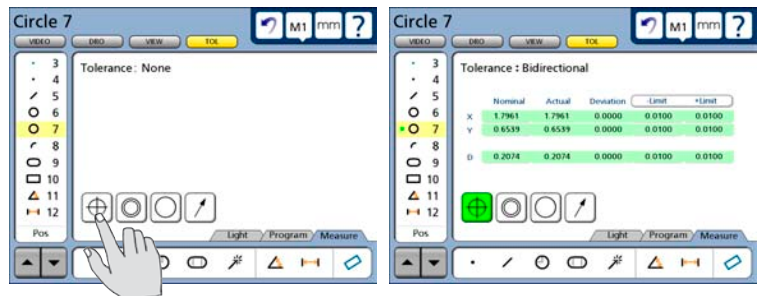



## Selecting a specific tolerance

Touch the Tolerance menu title and then select the specific tolerance from the drop-down menu. The true position tolerance is selected in this example.

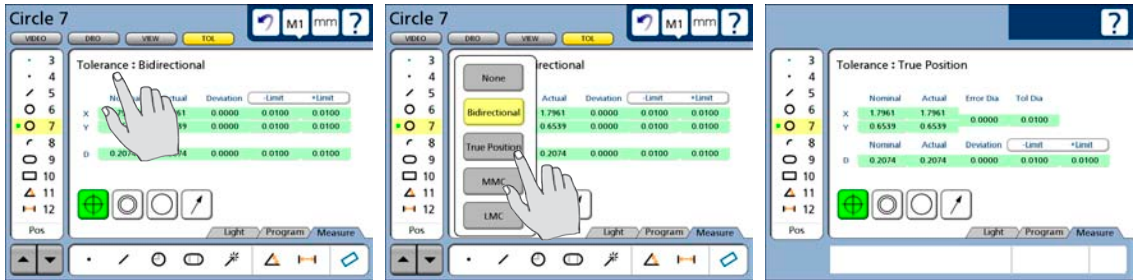

## Entering nominal, limit or tolerance values

In this example, the Nominal and Tol Dia (Tolerance diameter around the nominal position) values are entered by touching the desired data fields and entering a new values using the number keys. Error and Deviation values are generated as soon as the Nominal and Tol Dia values are entered.

### Tolerance : True Position

	Nominal	Actual	Error Dia	Tol Dia	
X	1.7961	1.7961	0.0000	0.0100	
Y	0.6539	0.6539	0.0000	0.0100	
D	0.2074	0.2074	0.0000	0.0100	0.0100

	Nominal	Actual	Deviation	-Limit	+Limit
D	0.2074	0.2074	0.0000	0.0100	0.0100

*The Nominal, Tol Dia and Limit values are entered...*

### Tolerance : True Position

	Nominal	Actual	Error Dia	Tol Dia	
X	1.8000	1.7961	0.0110	0.0250	
Y	0.6500	0.6539	0.0039	0.0250	
D	0.2000	0.2074	0.0074	0.0100	0.0100



  

	Nominal	Actual	Deviation	-Limit	+Limit
D	0.2000	0.2074	0.0074	0.0100	0.0100

*resulting in new error and deviation values*

Pass/fail results are indicated by green and red colors in the tolerance screen and in the feature list. Pass is indicated by green, fail is indicated by red in the tolerance screen.

Any tolerance failure will be indicated by a red square next to the feature in the feature list. A green square will be displayed in the feature list when all tolerance tests pass.

*Green square indicates pass* →   7

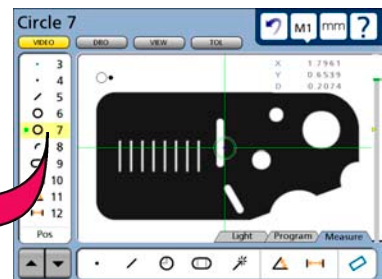

## Omitting a tolerance category

When a tolerance category is unnecessary, it can be omitted. To omit a category, select the Nominal data field, remove any data by repeatedly pressing the Cancel key and press the Enter key. In this example, the Diameter category is omitted.



*Touch the category to select it...*

*repeatedly press the Cancel key...*

*and press the Enter key*

## Tolerance types

As mentioned earlier, the method of applying tolerances to features is nearly identical for all tolerances. This section describes the tolerance screen for each tolerance type. The following tolerances can be applied to feature measurements:

- Bidirectional
- Runout
- Parallelism
- True position
- Roundness
- Perpendicularity
- MMC
- Concentricity
- Angle
- LMC
- Straightness
- Width

## Bidirectional

Bidirectional tolerances can be applied to points, lines, circles, arcs, slots and rectangles.

### Points

The tolerance screen for points is used to specify the acceptable deviation from a nominal position in the X, Y and Z axes. The bidirectional tolerance compares the measured location of a point to the nominal location of the feature's center point.

Enter the nominal values into the X, Y and Z axis data fields provided. Enter the allowed limits into the Limit data fields as +/- ranges or as absolute limits. Touch the Limit data fields to toggle between +/- ranges or absolute limits.

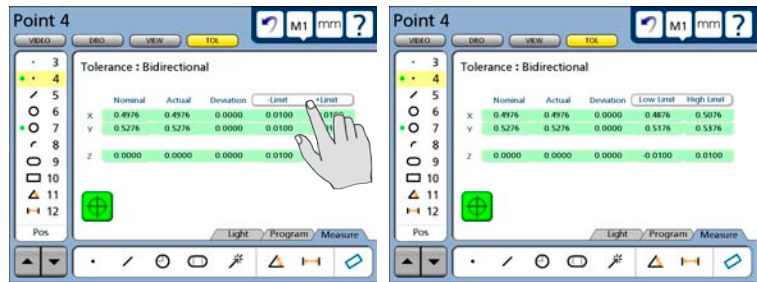

### Lines

The tolerance screen for lines is used to specify the acceptable deviation from nominal positions in the X and Y axes. The bidirectional tolerance compares the measured location of the center point of a line to the nominal location of the line's center point.

Enter the nominal values into the X and Y axis data fields. Enter the allowed limits into the Limit data fields as +/- ranges or as absolute limits. Touch the Limit data fields to toggle between +/- ranges or absolute limits.

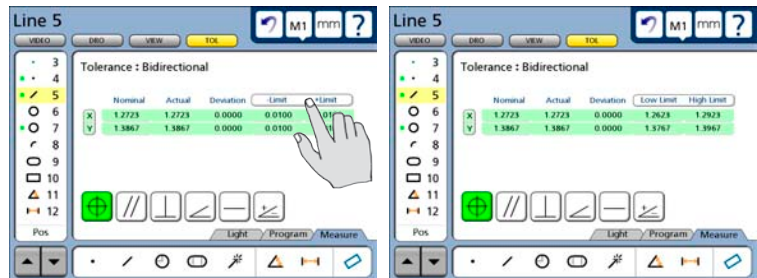

## Circles and arcs

The tolerance screens for circles and arcs are identical, and are used to specify the acceptable deviation from nominal positions in the X and Y axes, and from the nominal diameter or radius. The bidirectional tolerance compares the measured location of the center point of the arc or circle to the nominal center point and compares the measured diameter or radius to the nominal. Touch the D (diameter) or r (radius) choice field in the DRO screen to toggle between the display of diameter and radius if desired.

Enter the nominal values into the X and Y axis and D (diameter) data fields provided. Enter the allowed limits into the Limit data fields as +/- ranges or as absolute limits. Touch the Limit data fields to toggle between +/- ranges or absolute limits.

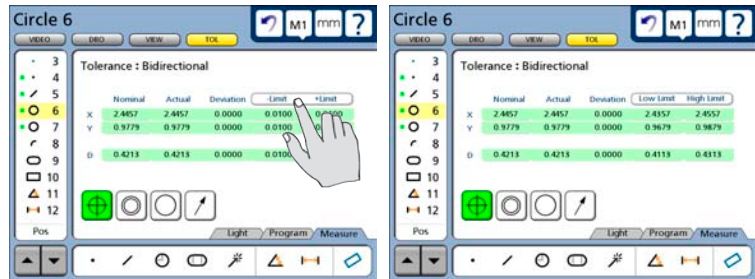

## Slots and rectangles

The tolerance screens for slots and rectangles are identical and are used to specify the acceptable deviation from nominal positions in the X and Y axes, and from the nominal length and width. The bidirectional tolerance compares the measured location of the center point of the slot or rectangle to the nominal center point and compares the measured size to the nominal size.

Enter the nominal values into the X-Y axis and L-W data fields provided. Enter the allowed limits into the Limit data fields as +/- ranges or as absolute limits. Touch the Limit data fields to toggle between +/- ranges or absolute limits.

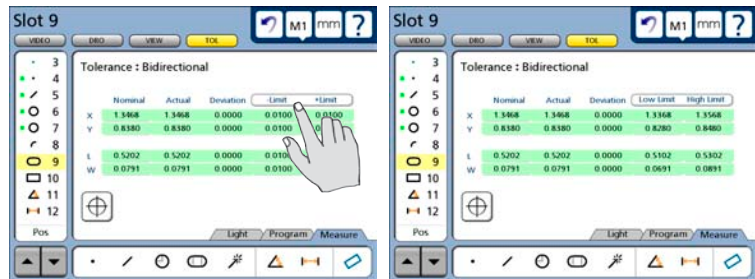

## True position

True position tolerances can be applied to points, lines, circles and arcs.

### Points and lines

The tolerance screens for points and lines are identical, and are used to specify the acceptable deviation from the nominal feature position. The true position tolerance compares the measured location of the center point to the nominal center point.

Enter the nominal values into the X and Y axis data fields. Enter the allowed tolerance diameter into the Tol Dia field.

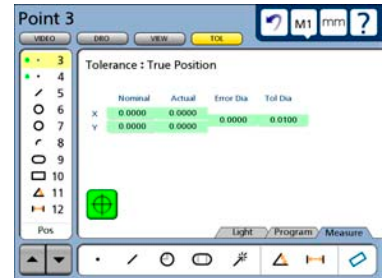

### Circles and arcs

The tolerance screens for circles and arcs are identical, and are used to specify the acceptable deviation from the nominal feature position, and from the nominal diameter. The true position tolerance compares the measured location of the center point of the circle or arc to the nominal center point and compares the measured diameter to the nominal diameter. Touch the D (diameter) or r (radius) choice field in the DRO screen to toggle between the display of diameter and radius if desired.

Enter the nominal values into the X and Y axis and D (diameter) data fields provided. Enter the allowed Tol Dia (Tolerance diameter) and feature diameter limits into the Limit data fields as +/- ranges or as absolute limits. Touch the Limit data fields to toggle between +/- ranges or absolute limits.

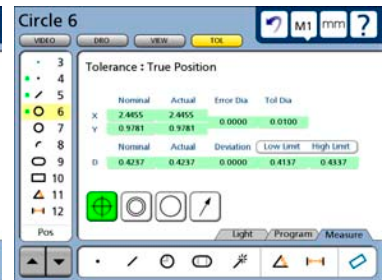
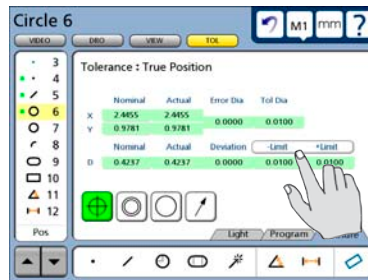

## MMC/LMC (Material condition)

MMC and LMC tolerances can be applied to bosses or to bores, compare measured center locations to the nominal centers and compare measured diameters to nominal diameters. MMC and LMC tolerances can be applied to circles and arcs.

### MMC Circles and arcs

The MMC tolerance screens for circles and arcs are identical, and are used to specify the maximum material that can exist within a bore or on the surface of a boss.

MMC tolerances generate position bonuses as a result of size tolerance surpluses. For example, when the size of a bore is larger than MMC, but within the acceptable tolerance range, a position tolerance bonus is generated for the bore and its acceptable location is given more flexibility. However, if a bore is within the position tolerance diameter, no position bonus is generated and the bore must be located exactly as specified.

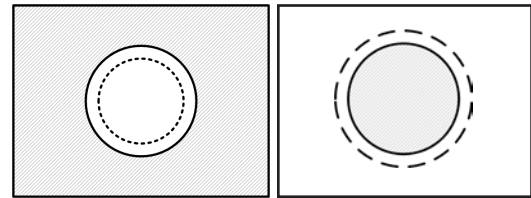

Maximum material within a bore

Maximum material on a boss

Touch the Boss or Bore choice field to specify the feature type as a Boss or a Bore.

Enter the nominal values into the X and Y axis and D (diameter) data fields provided. Enter the allowed Tol Dia (Tolerance diameter) and feature diameter limits into the Limit data fields as +/- ranges or as absolute limits.

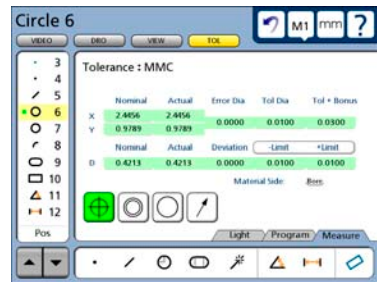
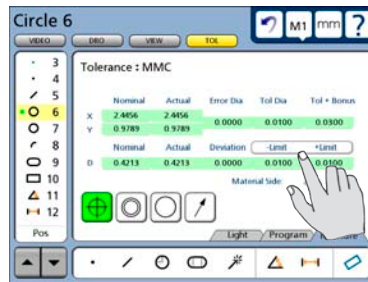

Touch the Limit data fields to toggle between +/- ranges or absolute limits.

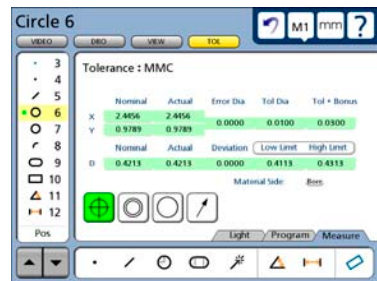
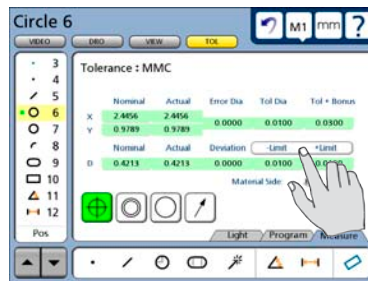

## LMC Circles and arcs

The LMC tolerance screens for circles and arcs are identical, and are used to specify the minimum material that can exist within a bore or on the surface of a boss.

LMC tolerances can generate position bonuses as a result of size tolerance surpluses. For example, when the size of a bore is smaller than LMC, but within the acceptable tolerance range, a position tolerance bonus is generated for the bore and its acceptable location is given more flexibility. However, if a bore is within the position tolerance diameter, no position bonus is generated and the bore must be located exactly as specified.

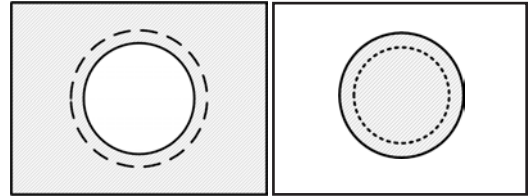

Minimum material within  
a bore

Minimum material on  
a boss

Touch the Boss or Bore choice field to specify the feature type as a Boss or a Bore.

Enter the nominal values into the X and Y axis and D (diameter) data fields provided. Enter the allowed Tol Dia (Tolerance diameter) and feature diameter limits into the Limit data fields as +/- ranges or as absolute limits.

Circle 6

Tolerance : LMC

	Nominal	Actual	Error Dia	Tol Dia	Tol + Bonus
X	2.456	2.456	0.0000	0.0100	0.0300
Y	0.9789	0.9789	0.0000	0.0100	0.0300
D	0.4213	0.4213	0.0000	0.0100	0.0100

Material Side:

Circle 6

Tolerance : LMC

	Nominal	Actual	Error Dia	Tol Dia	Tol + Bonus
X	2.456	2.456	0.0000	0.0100	0.0300
Y	0.9789	0.9789	0.0000	0.0100	0.0300
D	0.4213	0.4213	0.0000	0.0100	0.0100

Material Side: Boss

Touch the Limit data fields to toggle between +/- ranges or absolute limits.

Circle 6

Tolerance : LMC

	Nominal	Actual	Error Dia	Tol Dia	Tol + Bonus
X	2.456	2.456	0.0000	0.0100	0.0300
Y	0.9789	0.9789	0.0000	0.0100	0.0300
D	0.4213	0.4213	0.0000	0.0100	0.0100

Material Side:

Circle 6

Tolerance : LMC

	Nominal	Actual	Error Dia	Tol Dia	Tol + Bonus
X	0.0963	0.0963	0.0000	0.0004	0.0012
Y	0.0385	0.0385	0.0000	0.0004	0.0012
D	0.0166	0.0166	0.0000	0.0162	0.0170

Material Side: Boss

## Runout

Runout tolerances can be applied to circles and arcs. The tolerance screens are identical, and are used to specify the acceptable deviation from a circle or arc around the center of the Reference feature axis.

Enter the acceptable position deviation into the Tol Zone data field and then enter the number of the reference feature for the runout tolerance into the Ref Feature data field.

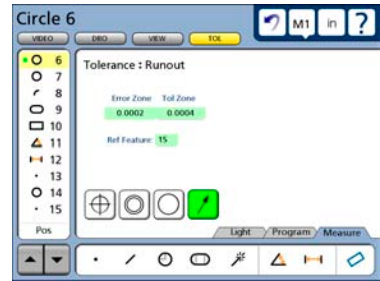

## Roundness

Roundness tolerances can be applied to circles and arcs. The tolerance screens are identical, and are used to specify the acceptable deviation from a perfect circle or circle segment.

Enter the acceptable form deviation into the Tol Zone data field.

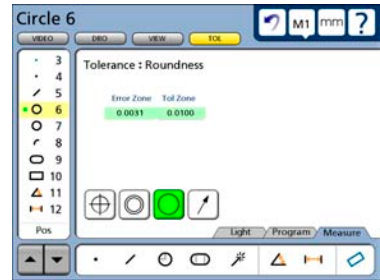

## Concentricity

Concentricity tolerances can be applied to circles and arcs. The tolerance entry screens are identical, and are used to specify the acceptable position deviation from a circle or arc concentric to a Reference feature.

Enter the acceptable position deviation into the Tol Zone data field and then enter the number of the reference feature for the Concentricity tolerance into the Ref Feature data field.

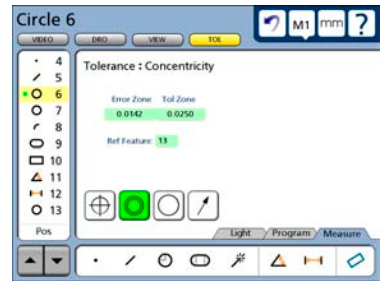

## Straightness

The straightness tolerance can be applied to lines and is used to specify the acceptable deviation from a perfect line.

Enter the acceptable form deviation into the Tol Zone data field .

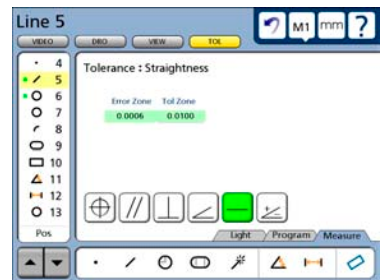



## Parallelism

Parallelism tolerances can be applied to lines and are used to specify the acceptable deviation from a line perfectly parallel to a Reference feature.

Enter the acceptable parallelism deviation into the Tol Zone data field, and then enter the number of the reference feature for the Parallelism tolerance into the Ref Feature data field.

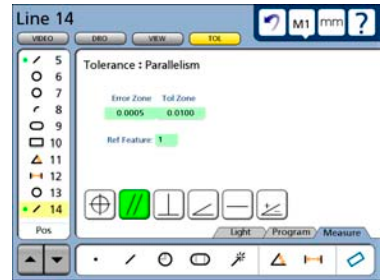

## Perpendicularity

Perpendicularity tolerances can be applied to lines and are used to specify the acceptable deviation from a line perfectly perpendicular to a Reference feature.

Enter the acceptable perpendicularity deviation value into the Tol Zone data field, and then enter the number of the reference feature for the Perpendicularity tolerance into the Ref Feature data field.

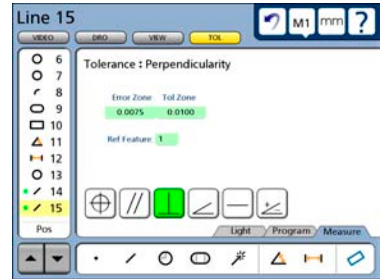

## Angle

Angle tolerances can be applied to lines and angles. The tolerance screens are identical, and are used to specify the acceptable deviation from a nominal angle.

Enter the allowed angle limits into the Limit data fields as +/- ranges or as absolute limits. Touch the Limit data fields to toggle between +/- ranges or absolute limits.

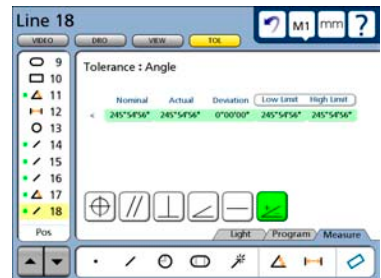
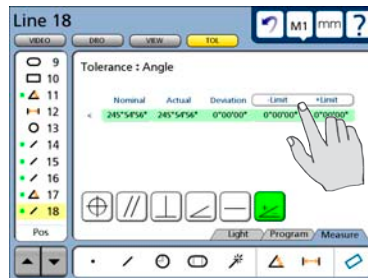

## Width

Width tolerances can be applied to distances and are used to specify the acceptable deviation from a nominal length. The length can be specified as a vector length (L) or as separate X, Y and Z lengths.

Enter the allowed width limits into the Limit data fields as +/- ranges or as absolute limits. Touch the Limit data fields to toggle between +/- ranges or absolute limits.

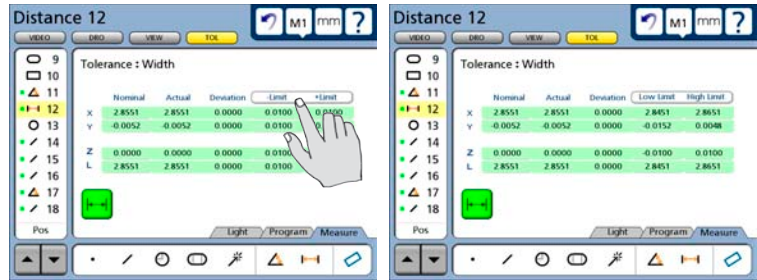

# Chapter 8:

# Programming

QC-300 programs are sequences of measurement activities performed on a part by the operator and stored by the system for playback later on other identical parts. Using the programming capabilities of the QC-300 greatly increases productivity by compressing the many manual steps required to measure, tolerance and report part dimensions into a few semi-automated steps which are little more than operator responses to system prompts.

Programs can be:

- Created (recorded)
- Edited
- Run on new parts
- Archived
- Deleted

## Creating programs

The basic programming process shown here is identical for all part types. The details of program recording are described in the remaining pages of this section and are included in an example that measures the largest hole in the QC Quickie slide, applies a position tolerance and prints the results.

*Enter messages that will be displayed for the operator as the program is played back. Messages can be inserted anywhere in the program.*

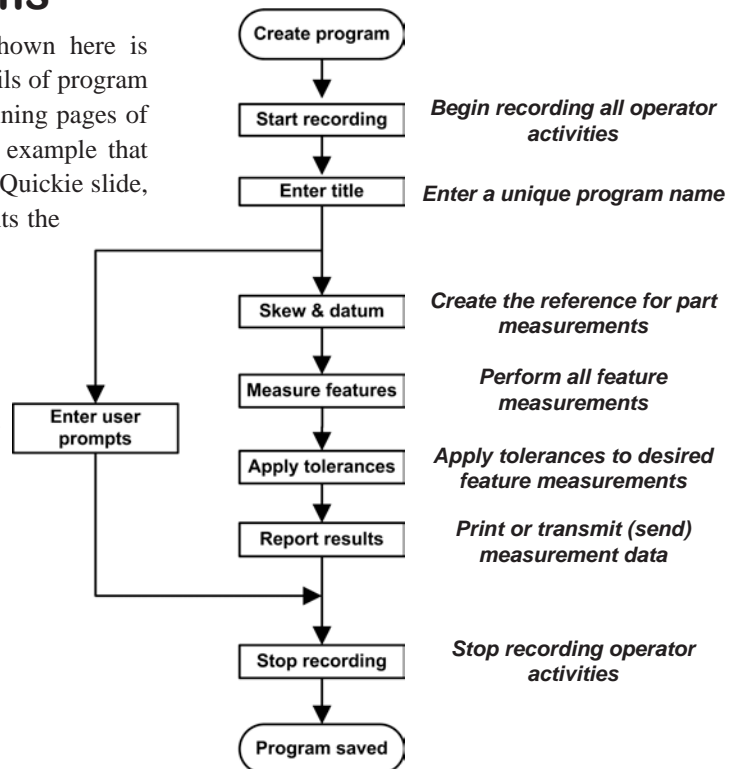

## Starting program recording

Touch the Program tab to display the programming tools. When no previous programs have been recorded, only the record icon will be shown. When other programs already exist, all the program tool icons will be shown.

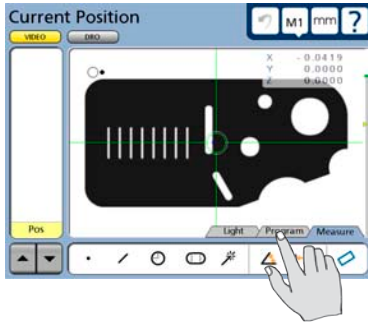

*Touch the Program tab...*

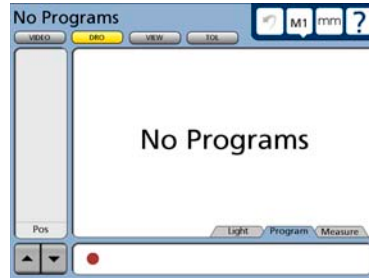

*to display the record icon when no other programs exist, or...*

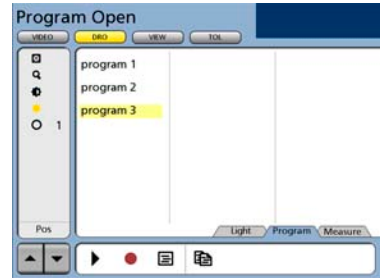

*to display all the programming icons when other programs do exist*

Touch the record icon to begin recording a program. The program title entry screen will be displayed.

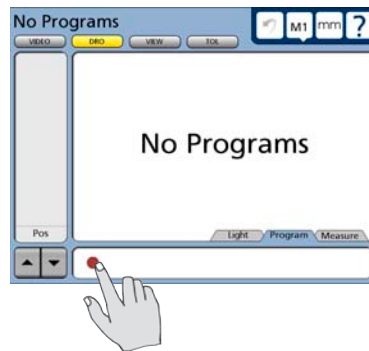

*Touch the record icon...*

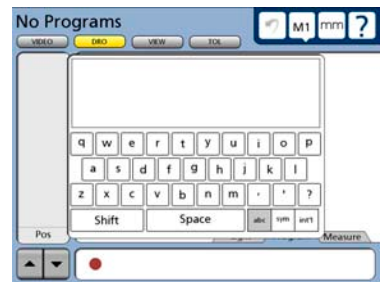

*to display the title entry screen*

## Entering a program title (or user message)

The method used to enter a program title is also used to enter any text message that will be played back during program execution as a user prompt.

To enter a program title:

Touch the character and control keys on the text entry screen to enter a unique name for your new program. The number keys on the front panel can also be used to enter numeric characters. Characters can be upper or lower case and can be separated by spaces.

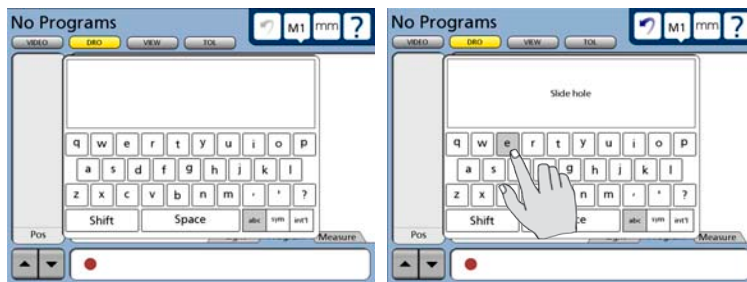

Touch the sym or int'l control keys to access symbol or international characters.

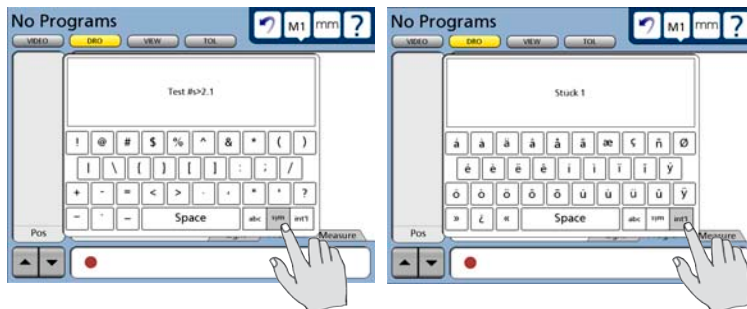

Press the Finish key to enter the new program name and begin recording the program. The DRO or Video screen will be displayed.

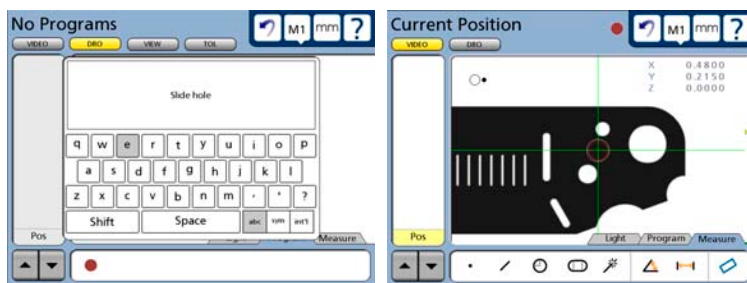

The system is now ready to record all datum, measurement, tolerance and reporting activities. Perform all the datum, measurement, tolerance and reporting activities just as you would if a program were not being recorded. Program recording is conducted by the system in the background and is invisible to the operator.

## Measuring a skew and creating a datum (including a message)

Skew and datum operations are described in [Chapter 6: Measuring](#). In this example, the bottom edge is measured for skew compensation, the left edge is measured and the intersection point of the bottom and left edge lines is zeroed in the X, Y and Z axes and used as a datum for subsequent measurements.

First, you may optionally create a message that prompts the user to perform the operations described above. Press the Finish key to complete the message.

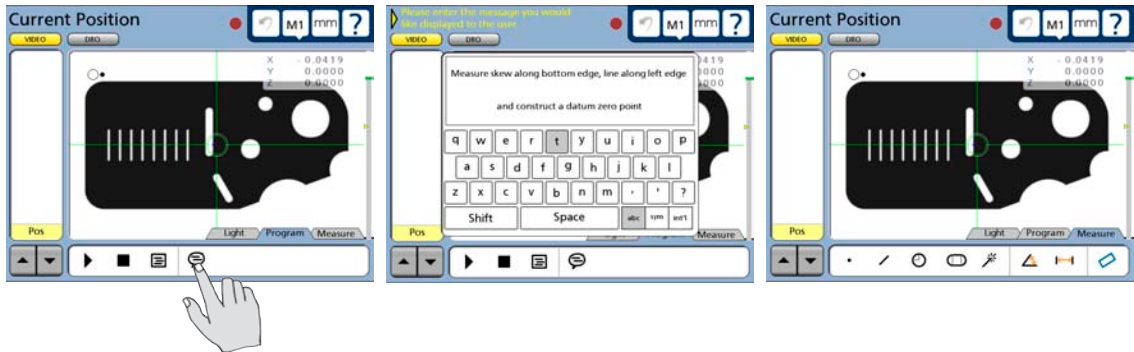

*Touch the message icon...*

*to include a user prompt message...*

*then press the Finish key to return to a measurement screen*

The details of skew and datum measurements are described in [Chapter 6: Measuring](#). Measure the skew and left side and then construct a zero datum point at the intersection of the two lines. Press the Video key to return to the Video measure screen.

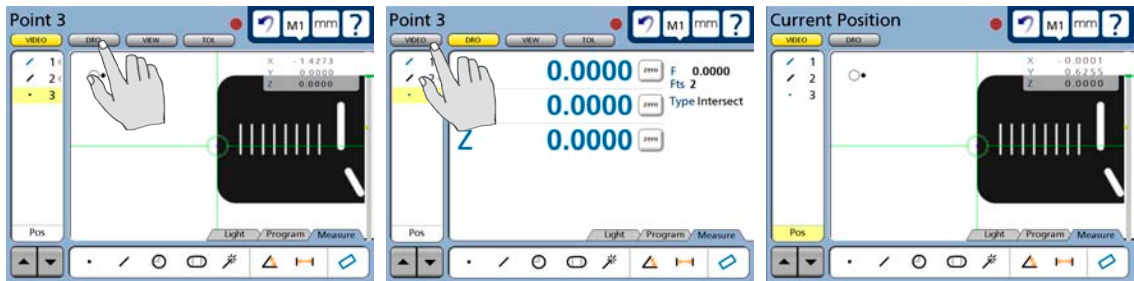

*The skew and left edge are measured, then the datum is constructed. Then the Video screen is displayed*

## Measure a feature (including a message)

Feature measurements are described in [Chapter 6: Measuring](#). In this example, the largest hole in the QCQuickie slide is measured.

First, you may optionally create a message that prompts the user to measure the hole. Press the Finish key to complete the message.

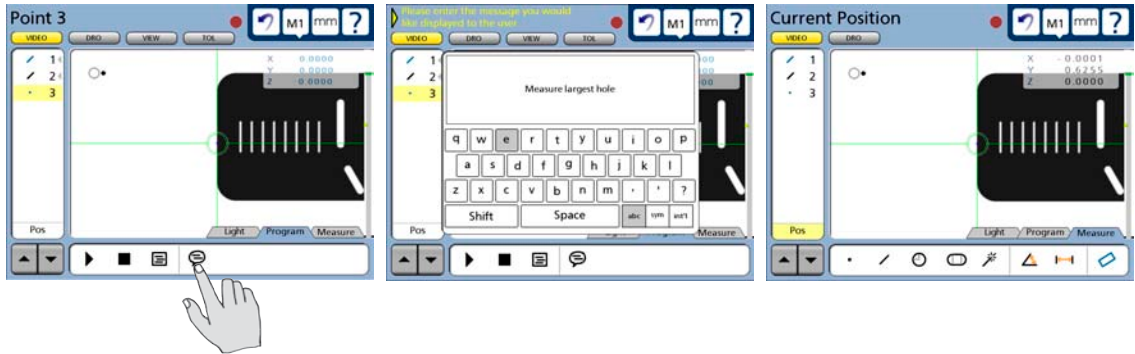

*Touch the message icon... to include a user prompt message... then press the Finish key to return to a measurement screen*

Details of performing circle measurements are described in [Chapter 6: Measuring](#). Measure the hole.

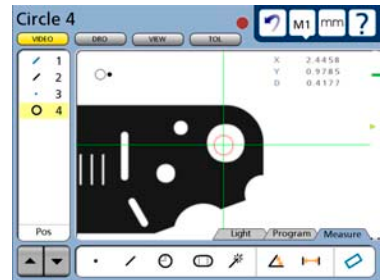

## Applying a tolerance

Tolerance operations are described in [Chapter 7: Tolerancing](#). In this example, a true position tolerance of 0.025 mm will be applied to the hole feature measured in the last step.

Touch the Tol button to display the Tolerance screen, apply the 0.025 mm true position tolerance and touch the Video button to return to the Video screen.

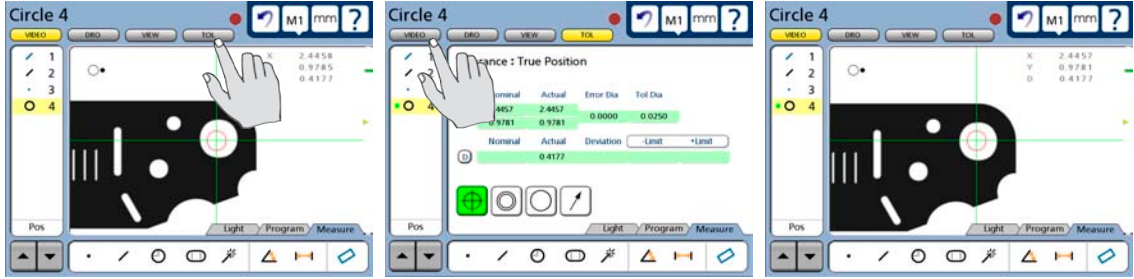

*Touch the Tol button...*

*apply the tolerance and touch the Video button...*

*to return to the Video screen*

## Reporting results

Measurement results can be printed on the USB port or transmitted to a computer on the RS232 serial port. Parameters governing reports and data transmissions are configured in the Print setup screen described in [Chapter 9: Communication](#), and in [Chapter 10: Setup](#).

Result reporting is included in a program by simply pressing the Print key while in recording a program.





## Stopping the program recording

Touch the Program tab to display the programming icons, and then touch the Stop icon to stop recording the program. The program title will be shown and program steps will be displayed in the feature list.

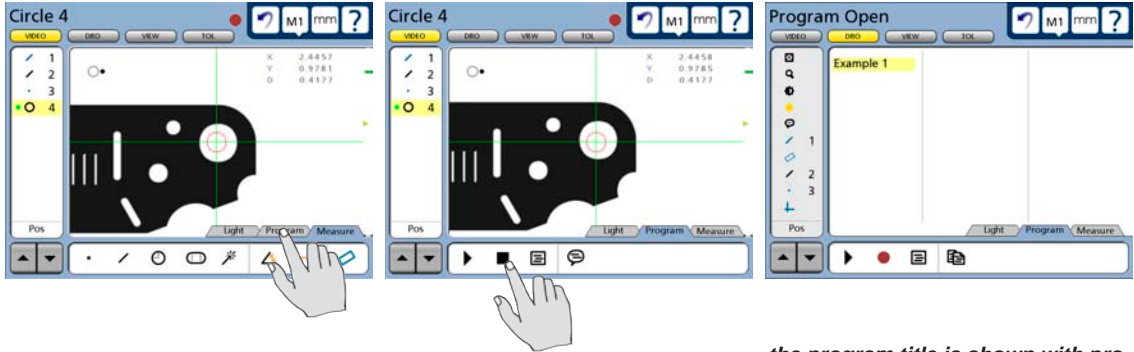

Touch the Program tab...

and then touch the Stop icon...

the program title is shown with program steps are in the feature list

The program is now saved and can be edited or run on new parts.

Touch the Measure tab to return to the measure mode of operation.

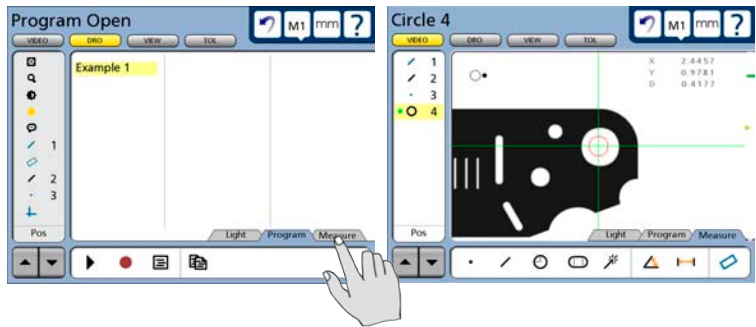

## Editing Programs

Programs can be edited to:

- Revise magnifications
- Revise tolerances
- Revise brightness and contrast
- Revise lighting
- Revise user prompt messages
- Append new steps to the end of the list of program steps

### Editing existing steps

The process for editing existing steps is diagrammed below and is identical for all types of revisions.

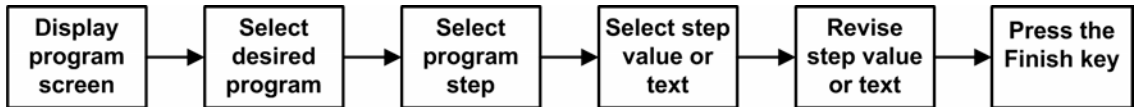

### Editing magnifications

To revise a magnification:

- 1 Touch the Program tab to display the program screen and then touch a program title to select the desired program.

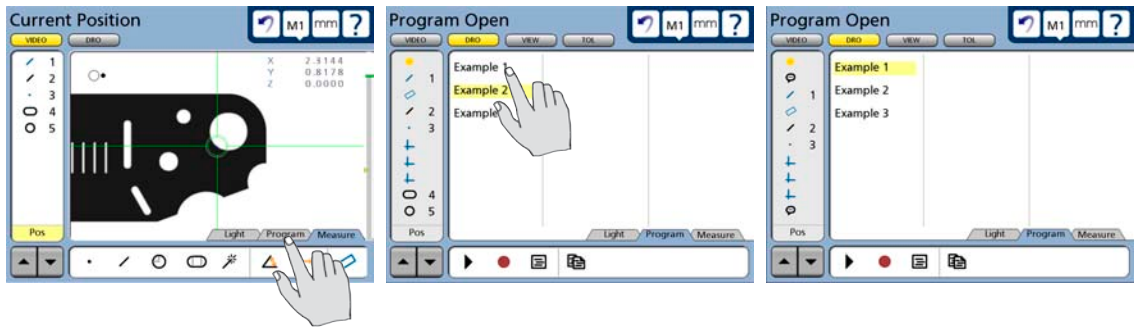

- 2 Touch the magnification step to display the magnification setting.

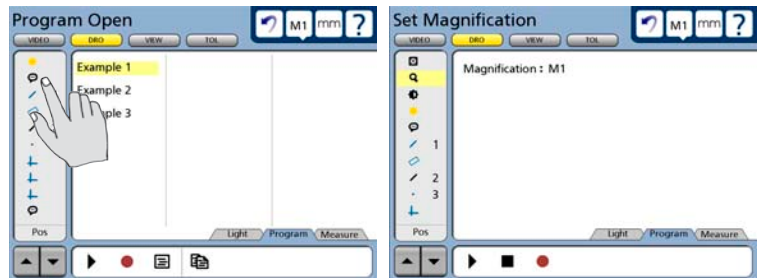

3 Touch the magnification setting to display all magnification alternatives.

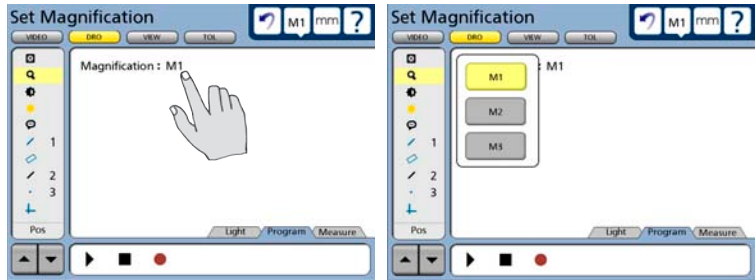

4 Touch the desired magnification and then either press the Finish key to save the revision and return to the measure mode, or proceed to the next revision.

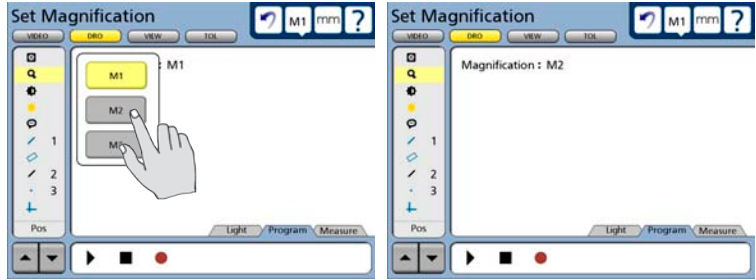

## Editing tolerances

To revise or add a tolerance:

1 Touch the Program tab to display the program screen and then touch a program title to select the desired program.

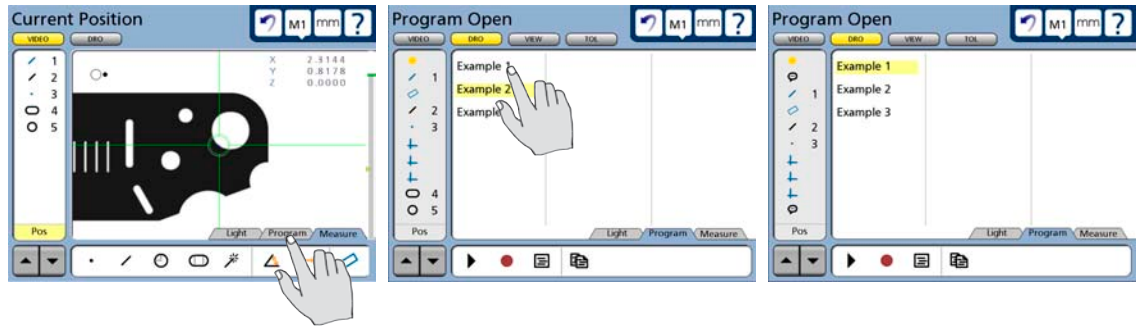

2 Touch the desired feature, touch the Tol button to display the tolerance screen and apply the new tolerances.

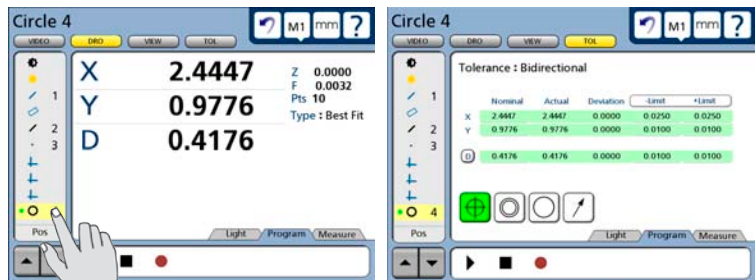

## Editing brightness and contrast

To revise a brightness and contrast levels:

- 1 Touch the Program tab to display the program screen and then touch a program title to select the desired program.

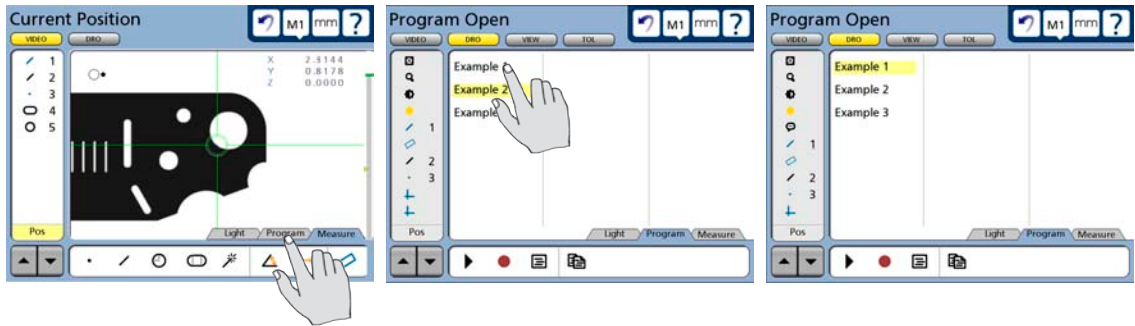

- 2 Touch the brightness/contrast step to display the brightness and contrast settings.

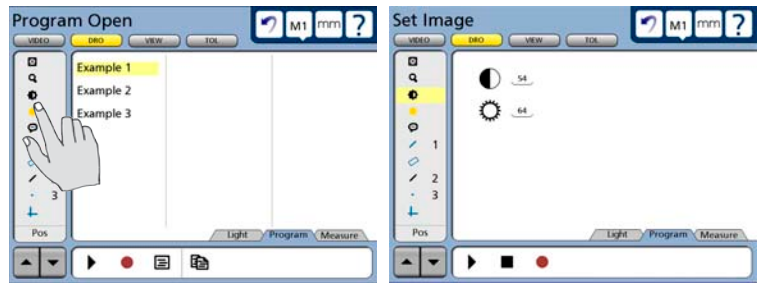

- 3 Touch the desired setting and enter the new value, then either press the Finish key to save the revision and return to the measure mode, or proceed to the next revision.

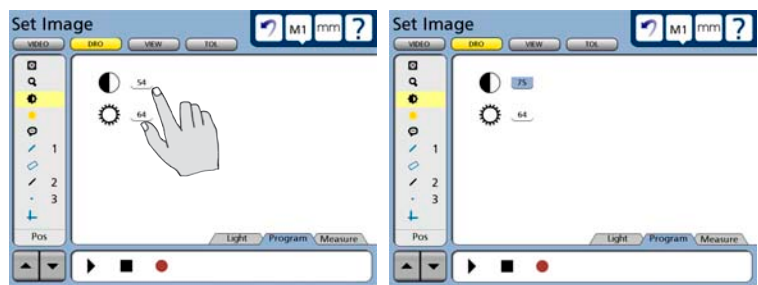

## Editing light intensities

To revise light intensity levels:

- 1 Touch the Program tab to display the program screen and then touch a program title to select the desired program.

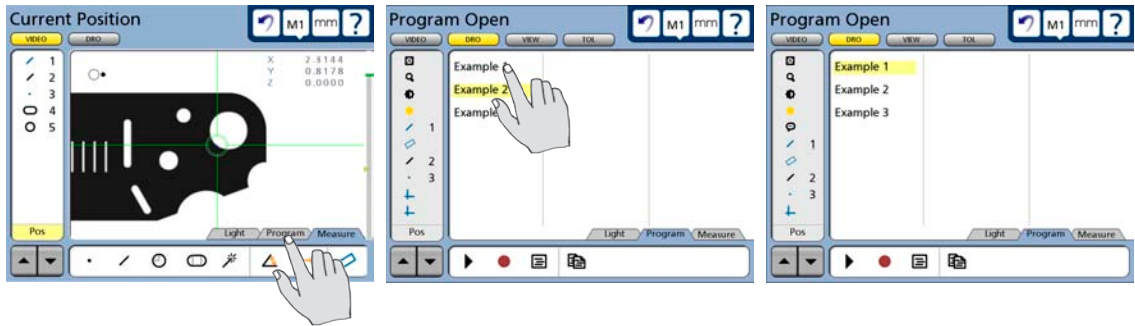

- 2 Touch the light intensity step to display the light intensity settings.

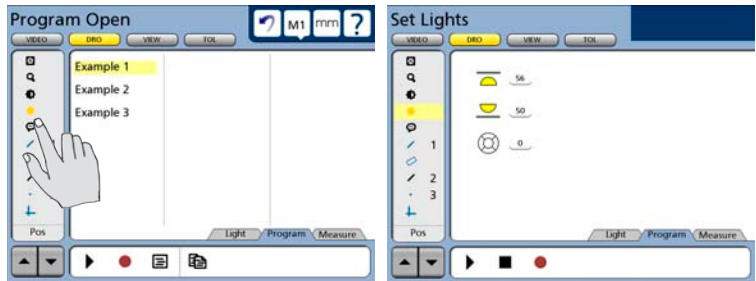

- 3 Touch the desired light setting and enter the new intensity value, then either press the Finish key to save the revision and return to the measure mode, or proceed to the next revision.

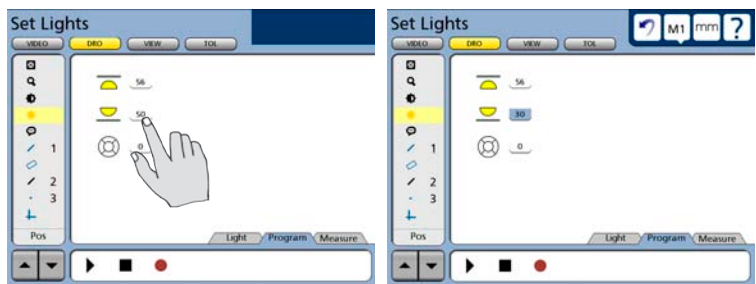

## Editing user prompt messages

To revise message text:

- 1 Touch the Program tab to display the program screen and then touch a program title to select the desired program.

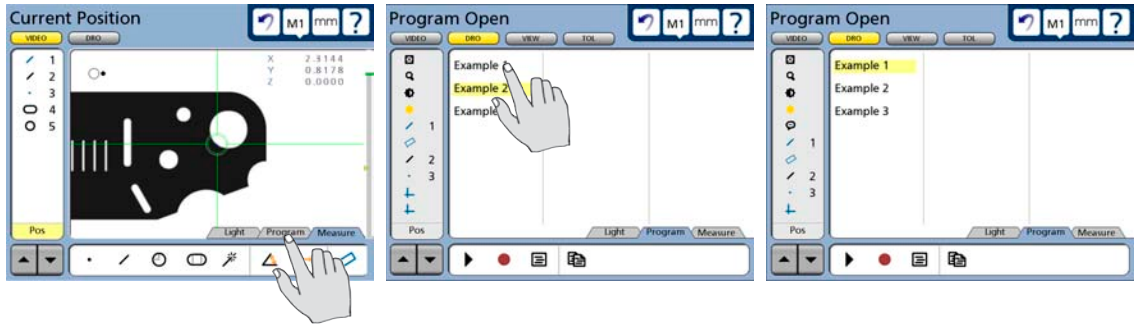

- 2 Touch the desired message step to display the message text.

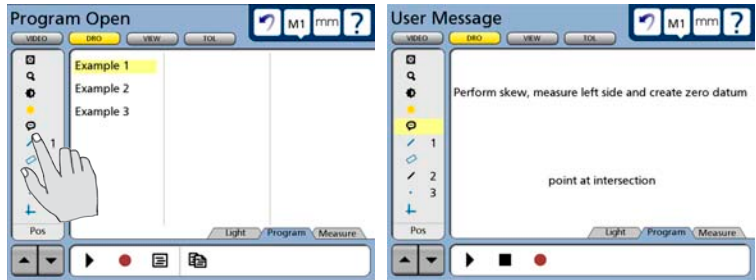

- 3 Touch the message text to display the text editing window and then enter the new text. The Cancel key is used to delete individual characters. When the editing is complete, either press the Finish key to save the revision and return to the measure mode, or proceed to the next revision.

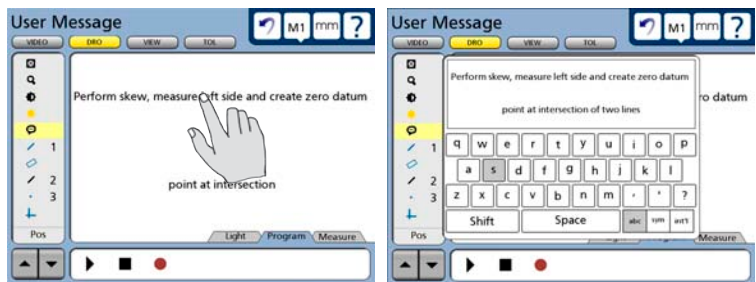

### Appending new program steps to an existing program

The process for appending new steps to an existing program is diagrammed below. As shown in the diagram, it is necessary to run the existing program before appending new steps so that all the preceding conditions created by the program will be correct when the new steps are added. For example, any datums created by the program will be current and correct up to the point that new steps are added.

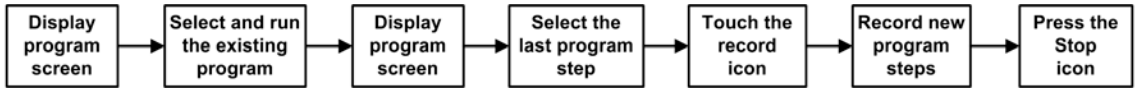

To append new steps to an existing program:

- 1 Touch the Program tab to display the program screen and then touch a program title to select the desired program.

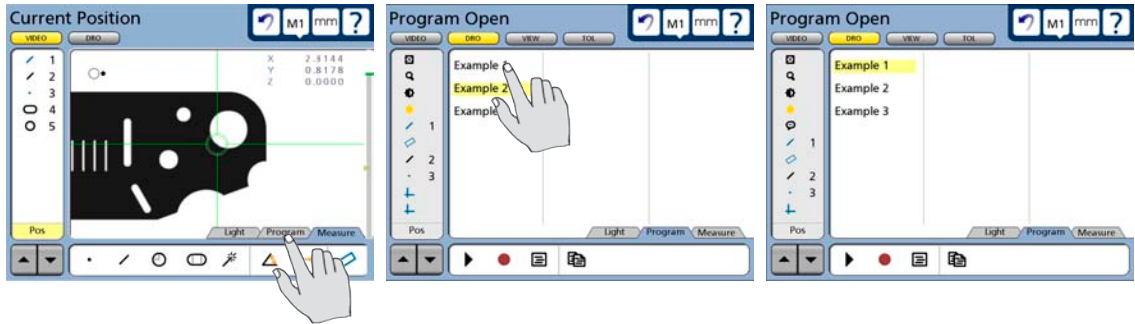

- 2 Touch the run icon to run the program and when execution is complete select the program screen again.

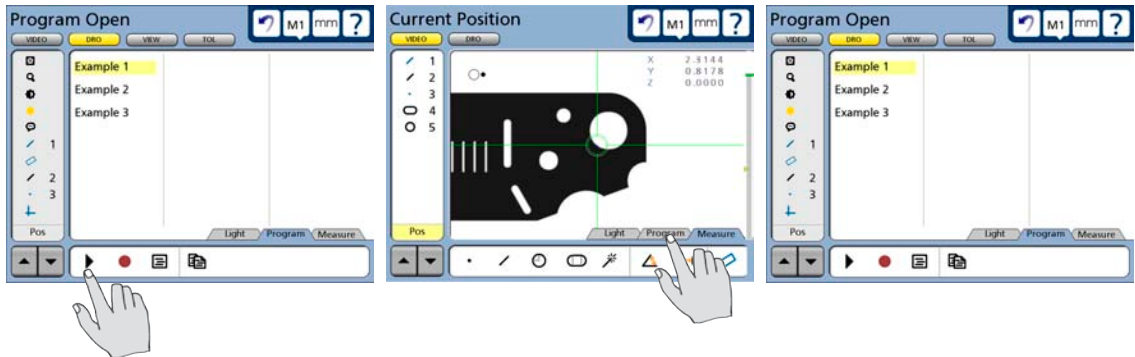

- 3 Scroll to the end of the program list if necessary and select the last program step.

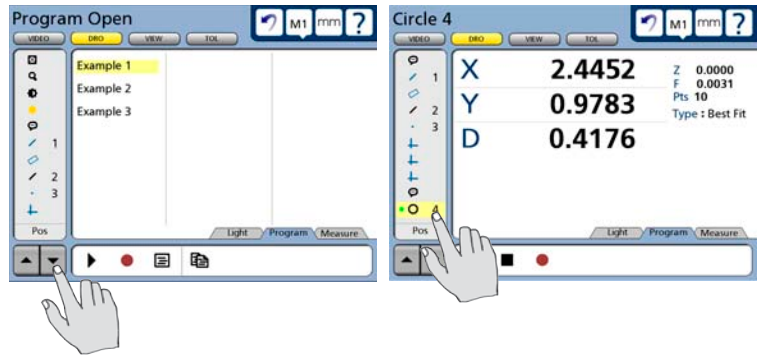

- 4 Touch the Record icon, touch the Measure tab and perform all the new program steps.

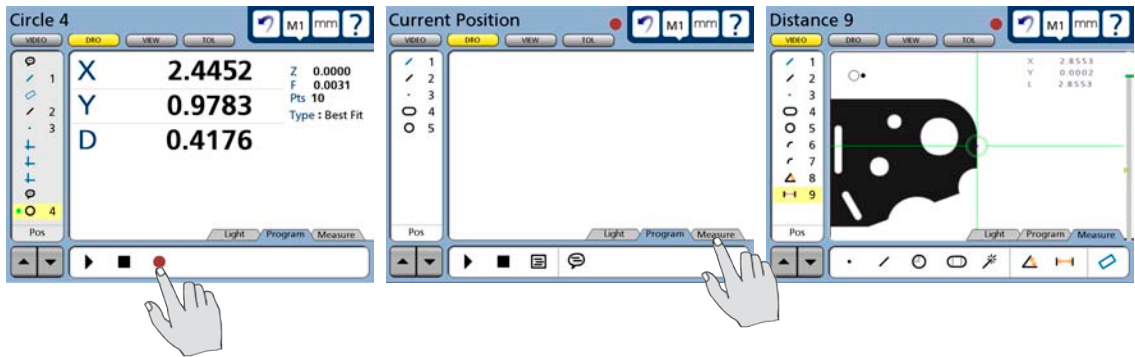

- 5 Touch the Program tab and touch the Stop icon to complete and save the program with its new steps.

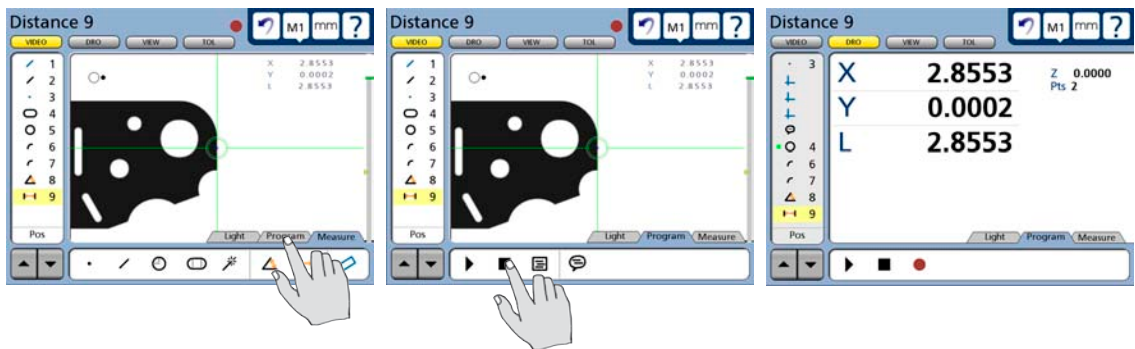



## Running programs

Programs are run by selecting the desired program and touching the Run icon as shown in this diagram.

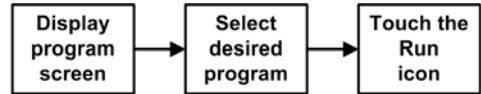

The operator will position the part and collect measurement data points in response to program text and the green run-time arrow displayed on the screen. When the program has successfully completed executing, feature data is shown in the feature list and the screen leaves the program execution mode and displays current position.

To run a program:

- 1 Touch the Program tab to display the program screen and then touch a program title to select the desired program.

Touch the Run icon to run the selected program.

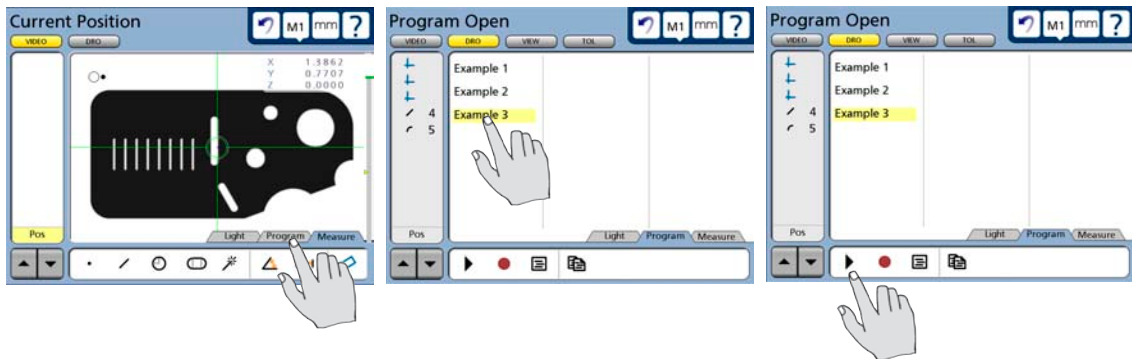

- 2 During execution after the datum is established, text and the green run-time arrow will guide the operator through the program measurement steps.

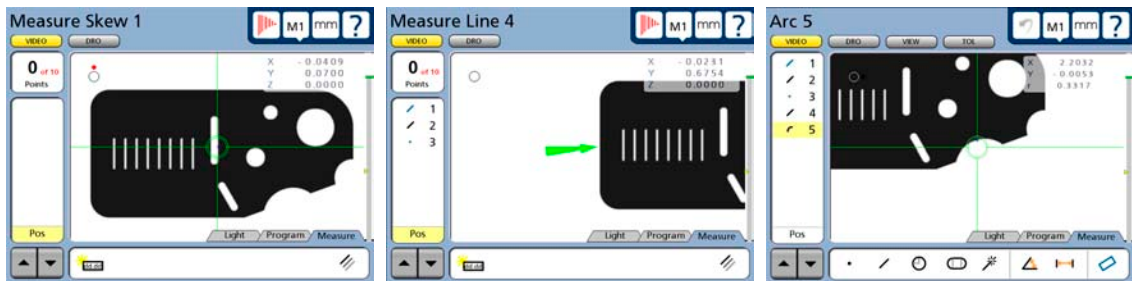

When the program is finished, the feature data will be shown in the Feature list and the current position will be shown.

## Archiving and retrieving programs

Programs are included in the settings files and can be saved and retrieved as part of the complete collection of all QC-300 system settings. To save or retrieve programs (and all system settings), touch the Save Settings or Load Settings button on the Supervisor setup screen.

Refer to [Chapter 10: Setup](#) for more details regarding the Save Settings and Load Settings functions.



### CAUTION

The settings include all operational parameters of the QC-300,

including SLEC and other error correction data. When the settings file is loaded from the USB drive, all existing settings will be overwritten and permanently replaced. Be sure that all program and settings data are appropriate for your system before loading a new file.

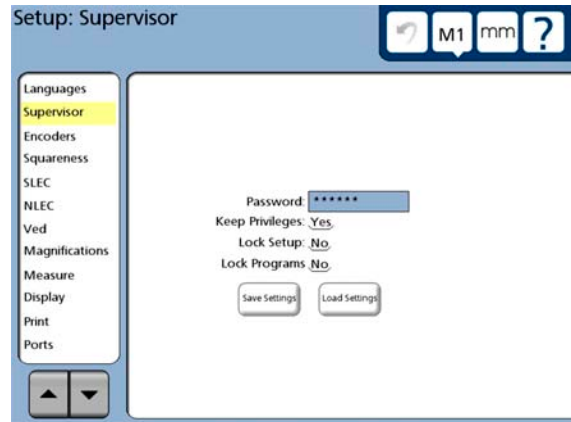

## Deleting programs

Programs are deleted by selecting the desired program and pressing the Cancel key. You will be asked to confirm your intention to delete the program.

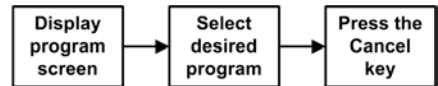

To delete a program, touch the Program tab to display the program screen and then touch a program title to select the desired program. Then press the Cancel key  to delete the program, then touch the Yes button to confirm your intention.

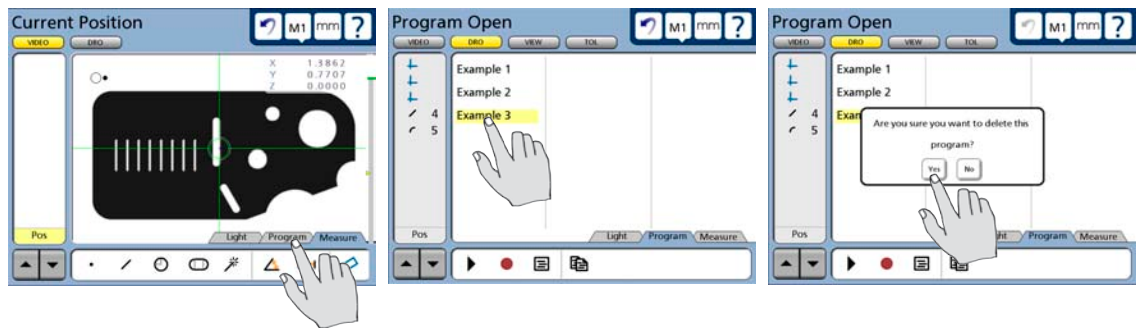

# Chapter 9:

# Communication

The QC-300 can communicate with a computer over a standard RS232 serial port and with printers over the USB port.

## Connecting to a computer

1 Verify that the QC-300 and computer power are off.

2 Connect a computer COM port to the QC-300 RS-232 serial port using a standard straight-through serial cable (Metronics part number 11B12176). Make sure the cable connectors are tight, but do not overtighten the connector screws.

3 Apply power to the computer, and then the QC-300. The default QC-300 settings for communication over the RS-232 serial port are shown here.

- Baud rate: 9600
- Parity: None
- Data bits: 7
- Stop bits: 1
- Flow control: Hardware

4 Launch the computer application that will be used to communicate with the QC-300, and configure the communication properties of the COM port to match those of the QC-300.



## Sending data to a computer

Feature measurement data can be sent to a computer over the RS-232 serial port in the following formats:

- None No data will be sent to the computer
- Select User will be prompted to select the data that will be sent
- Report A standard report of all feature data or a tolerance report of only features that have tolerances applied will be sent
- Screen Only the encoder values currently shown on the DRO screen (current position) will be sent. Screen values can be sent each time the print key is pressed, or can be buffered and sent when an entire page of values is ready.

To send data to a computer:

1 Touch the question mark Icon and display the setup menu, then display the Print setup screen.

2 Verify that the desired data is specified in the Print Button choice field. None, Select, Report or Screen can be specified. If Screen is specified, set the Buffer Page choice field as desired. In this example, the Report is specified.

Print Button: Report

3 Verify that the Serial Device is specified in the Destination field. In this example, the communication will be with a computer, so the Serial port is specified.

Destination: Serial Device

4 Verify that the desired report is specified in the Report Type setup choice field. Standard or Tolerance can be specified. In this example, a Tolerance report is specified.

Report Type: Tolerance

5 Specify other settings that are consistent with the computer application's requirements.

6 Press the Finish key to exit the setup mode, and then press the Print key to send the data to a computer.

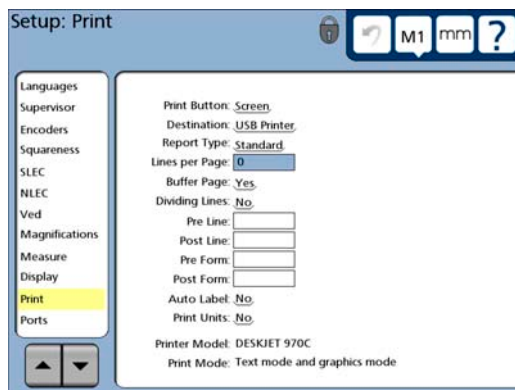

## Connecting a printer

The QC-300 supports certain HP USB printers. The printer must be approved for use by Metronics. The current printer is shown in the Print setup screen discussed in [Chapter 10: Setup](#).

1 Verify that the QC-300 and printer power are off. Connect the USB printer to the USB Type A port on the side of the enclosure, or connect the parallel printer to the parallel port connector on the rear connector panel.

2 Make sure the USB cable plug is fully inserted, or that the parallel connector is tight, but be careful not to overtighten the connector screws.



### Printer format strings

The formatting strings listed below include one or more ASCII codes listed at the end of this chapter. This formatting is configured in the Print setup screen discussed in [Chapter 10: Setup](#).

- Pre Line: ASCII control character (or string) for printer control before printing a line.
- Post Line: ASCII control character (or string) for printer control after printing a line.
- Pre Form: ASCII control character (or string) for printer control before printing a form.
- Post Form: ASCII control character (or string) for printer control after printing a form.

### Report formats

Reports of feature measurement data can be printed with the formats discussed in the Print setup screen portion of [Chapter 10: Setup](#). These can include:

- Number of lines per page
- Form
- Pre/Post line formats
- Pre/Post formats
- Axis labels
- Units of measure

QC-300 Feature Print Out						
Date	Time		Operator			
Job			Part			
NO.	FEATURE	ID	UNITS	POSITION	DIMENSION	FORM
001	Point	1	mm	X = -0.876 A DMS Y = -0.175		
002	Line	2	mm	X = -0.120 A DMS Y = -0.152	< = 82.41.16	+T = 0.000 -T = 0.000
003	Circle	3	mm	X = 0.464 A DMS Y = -0.073	r = 0.073 d = 0.145	+T = 0.000 -T = 0.000
004	Distance	4	mm		X = 2.273 Y = 0.711	
005	Line	5	mm	X = 0.116 A DMS Y = 0.174	< = 30.15.23	+T = 0.000 -T = 0.000
006	Line	6	mm	X = -0.116 A DMS Y = -0.174	< = 77.44.45	+T = 0.000 -T = 0.000
007	Angle	7	mm	X = -0.063 A DMS Y = 0.070	<1= 132.30.37 <2= 227.29.22	
008	Line	8	mm	X = 0.000 A DMS Y = 0.000	< = 270.00.00	+T = -T =

## Printing a report

Feature measurement data or record of QC-300 system settings can be printed at the USB port.

### Printing feature measurement data

Feature measurement data can be printed in the following formats:

- None No data will be printed
- Select User will be prompted to select the data that will be printed
- Report A standard report of all feature data or a tolerance report of only features that have tolerances applied will be printed
- Screen Only the encoder values currently shown on the DRO screen (current position) will be printed. Screen values can be printed each time the print key is pressed, or can be buffered and printed when an entire page of values is ready.

To print feature measurement data:

1 Touch the question mark Icon and display the setup menu, then display the Print setup screen.

2 Verify that the desired data is specified in the Print Button choice field. None, Select, Report or Screen can be specified. If Screen is specified, set the Buffer Page choice field as desired. In this example, the Report is specified.

Print Button: Report

3 Verify that the Serial Device is specified in the Destination field. In this example, the file will be printed to a USB printer, so the USB Printer is specified.

Destination: USB Printer

4 Verify that the desired report is specified in the Report Type setup choice field. Standard or Tolerance can be specified. In this example, a Standard report is specified.

Report Type: Standard

5 Specify other settings that are consistent with the computer application's requirements.

6 Press the Finish key to exit the setup mode, and then press the Print key to send the data to the printer.

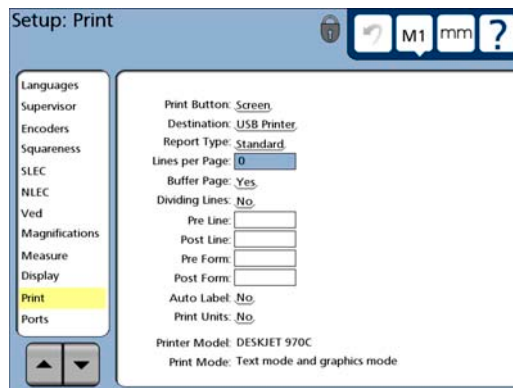

## Printing QC-300 system settings

To print a report of the QC-300 setup parameters:

- 1 Touch the question mark Icon and display the setup menu.
- 2 Press the Print key.

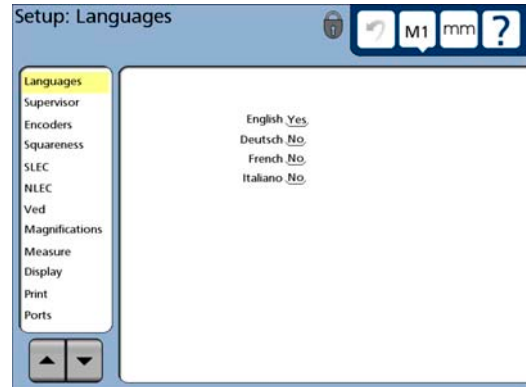

## RS232 connector pin designations

Pin No.	Description	Direction
2	Data in	Input
3	Data out	Output
7	Signal ground	Reference
8	Power on	Output (always high)

## ASCII Code table

ASCII Codes

8	backspace	46	.	84	T
9	horizontal tab	47	/	85	U
10	line feed	48	0	86	V
11	vertical tab	49	1	87	W
12	form feed	50	2	88	X
13	carriage return	51	3	89	Y
14	so	52	4	90	Z
15	si	53	5	91	[
16	dle	54	6	92	\
17	dcl	55	7	93	]
18	dc2	56	8	94	^
19	dc3	57	9	95	~
20	dc4	58	:	96	·
21	nak	59	;	97	a
22	syn	60	<	98	b
23	etb	61	=	99	c
24	can	62	>	100	d
25	em	63	?	101	e
26	sub	64	@	102	f
27	esc	65	A	103	g
28	fs	66	B	104	h
29	gs	67	C	105	i
30	rs	68	D	106	j
31	us	69	E	107	k
32	space	70	F	108	l
33	!	71	G	109	m
34	"	72	H	110	n
35	#	73	I	111	o
36	\$	74	J	112	p
37	%	75	K	113	q
38	&	76	L	114	r
39	'	77	M	115	s
40	(	78	N	116	t
41	)	79	O	117	u
42	*	80	P	118	v
43	+	81	Q	119	w
44	comma (,)	82	R	120	x
45	-	83	S	121	y
				122	z



# Chapter 10: Setup

The operating parameters of the QC-300 must be configured prior to using the system for the first time, and any time part measurement, reporting or communication requirements change. Day to day use of the QC-300 does not require reconfiguration of system settings.

The Setup Menu .....	176
Accessing and using the Setup Menu .....	176
Essential setup requirements .....	180
Setup screen descriptions .....	180
Language screen .....	181
Supervisor screen .....	182
Encoders screen .....	184
Squareness screen .....	187
SLEC screen.....	188
VED screen .....	193
Magnifications screen .....	196
Measure screen.....	203
Display screen.....	206
Print screen.....	210
Ports screen .....	212
Clock screen .....	213
Sound screen .....	214
Miscellaneous screen .....	215



## CAUTION

**Parameter changes made in any of the setup screens affect the operation of the QC-300. For this reason setup screens should be password-protected. Only qualified supervisory personnel should be given password access to setup screens.**

## The Setup Menu

All setup operating parameters of the QC-300 are configured using screens accessed from the setup menu. Touching setup menu items on the left side of the setup screen display the corresponding setup parameter data fields and choice fields on the right side of the screen.

Setup menu item

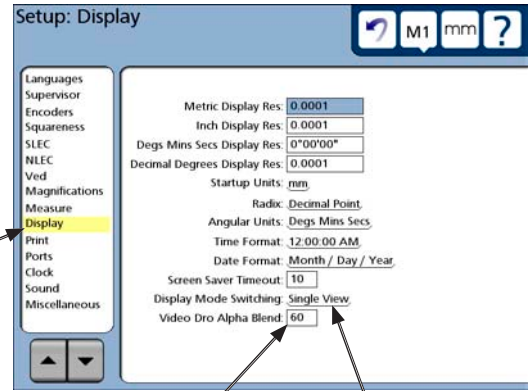

Setup data field

Setup choice field

Parameters configured in setup screens will be retained by the QC-300 until:

- The data-backup battery is changed
- The system data and settings are cleared by maintenance personnel
- They are changed using the setup menu screens
- Certain software upgrades are performed

## Accessing and using the Setup Menu

QC-300 operating parameters are entered into the system using touch screen selections and keys located on the front panel. The configuration process is facilitated by a simple menu structure of setup functions that can be quickly navigated on the large color LCD display.

The setup screens and functions are accessed from other screens by touching the Help (?) button, and then pressing the Setup button twice. Access to most setup parameter fields is restricted to users that can provide the supervisor password.

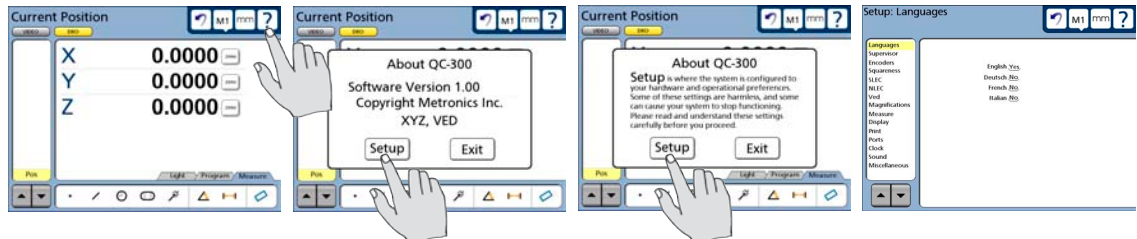

Touch the ? button...

then touch the Setup button twice...

for the Setup screen

### Entering the supervisor password

The supervisor password must be entered into the Supervisor setup screen to access most setup fields. To enter the supervisor password:

1 Access the setup menu as described on the previous page.

2 Touch the Supervisor menu item, enter the supervisor password using the number keys on the front panel and press the Enter key.

Password:   
 Keep Privileges: No  
 Lock Setup: No  
 Lock Programs: No

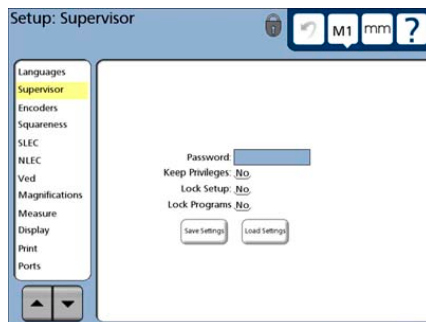

3 Setup editing privileges can be retained until the QC-300 power is cycled, eliminating the need to reenter the password if another setup editing session is required. Touch the Keep Privileges choice field to toggle the Keep Privileges parameter from No to Yes.

Password:   
 Keep Privileges: No  
 Lock Setup: No  
 Lock Programs: No



Password:   
 Keep Privileges: Yes  
 Lock Setup: No  
 Lock Programs: No

4 Views of the Setup can be locked so that the supervisor password is required to see the setup parameter settings. Touch the Lock Setup choice field to toggle the Lock Setup parameter from No to Yes, then delete the password from the Password field and press the Finish key.

Password:   
 Keep Privileges: Yes  
 Lock Setup: No  
 Lock Programs: No



Password:   
 Keep Privileges: Yes  
 Lock Setup: Yes  
 Lock Programs: No

Password:   
 Keep Privileges: Yes  
 Lock Setup: Yes  
 Lock Programs: No

5 Operator access to program functions can be limited to running existing programs by toggling the Lock Programs choice field to Yes. Touch the Lock Programs choice field to toggle the setup parameter from No to Yes.

Password:   
 Keep Privileges: Yes  
 Lock Setup: No  
 Lock Programs: No



Password:   
 Keep Privileges: Yes  
 Lock Setup: No  
 Lock Programs: Yes

### Selecting items from the Setup Menu

Setup menu items are selected by touching the item on the left side of the screen. Menu items will become highlighted to indicate that the selection is complete and the corresponding setup parameter choice and data fields will be shown on the right side of the screen. Touch the up or down scroll arrow to scroll to the desired menu item.

### Selecting setup parameter choices

Many setup parameters are selected from two choices: Yes or No. Other setup parameters offer more choices to the user. In all cases, selections are made by repeatedly touching the choice field to cycle through all the available parameter setting choices.

In this example, the RS232 Port Parity choices are shown by repeatedly touching the Parity choice field.

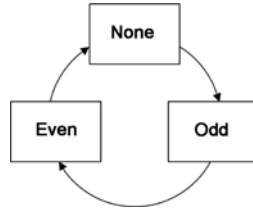

### Entering and deleting setup data

Some setup parameters must be entered as numeric values into setup data fields. To enter setup data, touch the desired data field and enter the data using the number keys. In this example, the RS232 Port EOC Delay data field is selected and data is entered using the number keys. Obsolete or erroneous setup data is deleted from a highlighted data field by pressing the Cancel key.

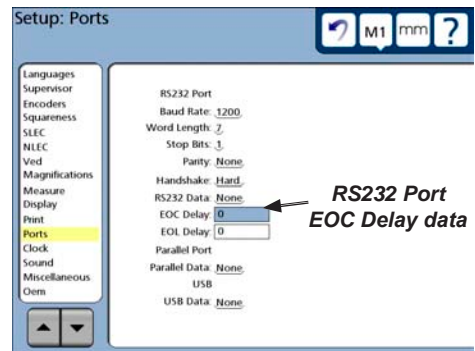
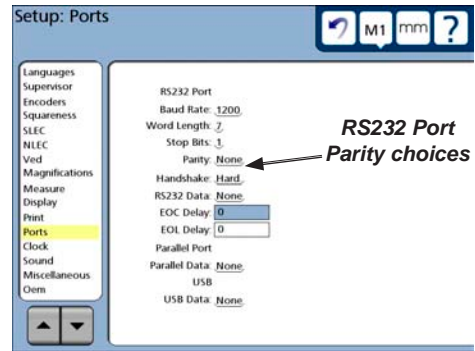
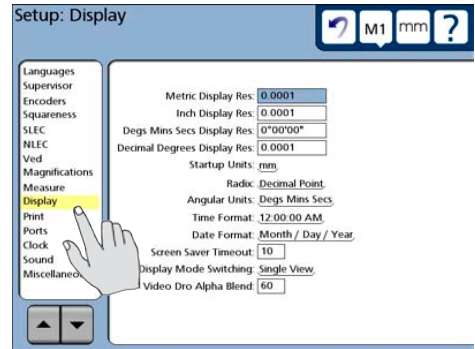
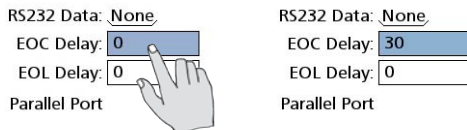

***Storing a parameter and advancing to the next step***

Press the Enter key to store the highlighted value and advance to the next setup field.

***Leaving the setup menu***

Press the Finish key to conclude the setup session.

## Essential setup requirements

The essential steps required to prepare a QC-300 for operation are presented in the required order of execution by this block diagram. Each block describes a setup task and refers to pages where detailed instructions are presented.

A variety of optional setup steps can be performed after the essential setup to specify display, reporting and other parameters. These optional and all other setup parameters and screens are described in detail following this description of the essential setup.



**Make sure that you're familiar with the methods of accessing and using the Setup menu described on the preceding pages of this chapter before performing essential or optional setup steps.**

## Setup screen descriptions

The setup screen descriptions are presented in the order of their appearance in the setup menu. However, the first time the QC-300 is configured, the order of setup screen use should follow the essential setup requirements diagram, and then continue in the order that best satisfies the application or the user's preferences. The subsequent use of setup screens will probably be infrequent and will address part requirement or hardware changes.

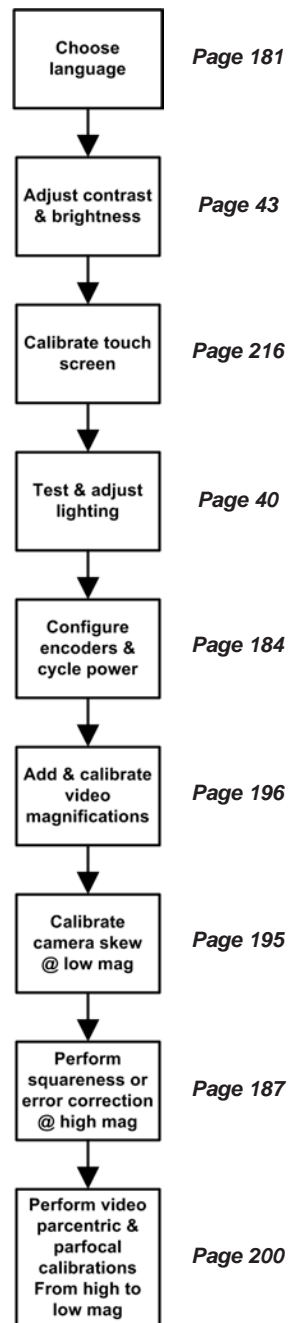

## Language screen

The Language screen contains selections for changing the language of text displayed on the LCD, included in transmitted data and printed on reports.

### ***Specifying the displayed language***

Touch the desired language to toggle the language choice to Yes.

English <u>Yes</u>	English <u>No</u>
Deutsch <u>No</u>	Deutsch <u>Yes</u>
French <u>No</u>	French <u>No</u>
Italiano <u>No</u>	Italiano <u>No</u>

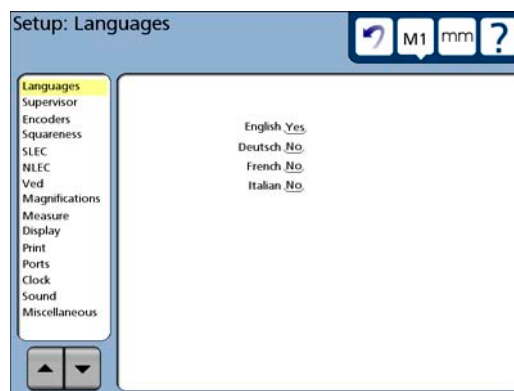
## Supervisor screen

The Supervisor screen contains fields for entering the supervisor password, choosing to keep privileges until the power is cycled and locking the setup menu so that setup parameters cannot be viewed. Button controls are also provided for saving system settings to, or loading setting from the USB port.

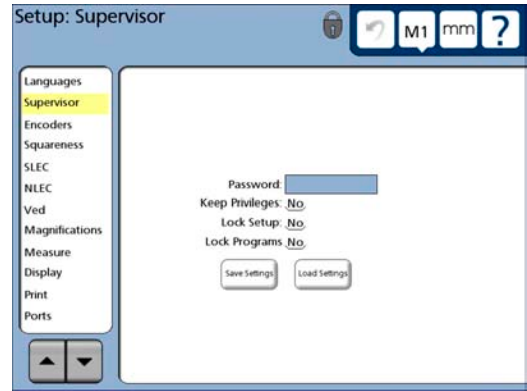

### Entering the supervisor password

The supervisor password must be entered into the Supervisor setup screen to access most setup fields. To enter the supervisor password, touch the Supervisor menu item, enter the supervisor password using the number keys on the front panel and press the Enter key.

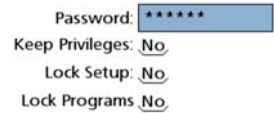

### Keeping setup privileges until the power is cycled

Setup editing privileges can be retained until the QC-300 power is cycled, eliminating the need to reenter the password if another setup editing session is required. To retain setup privileges, touch the Keep Privileges to toggle the Keep Privileges parameter from No to Yes.

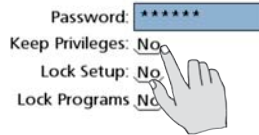

### Hiding setup parameters from unauthorized personnel

Views of the Setup can be locked so that the supervisor password is required to see the setup parameter settings. Touch the Lock Setup choice field to toggle the Lock Setup parameter from No to Yes, then delete the password from the Password field and press the Finish key.

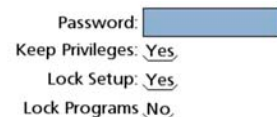
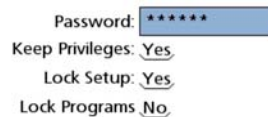
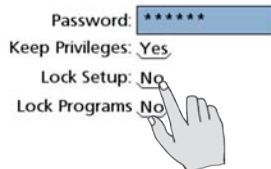

### Limiting access to program functions

Operator access to program functions can be limited to running existing programs by toggling the Lock Programs choice field to Yes. Touch the Lock Programs choice field to toggle the setup parameter from No to Yes.

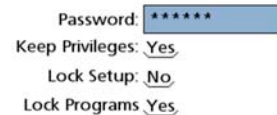



### ***Saving and loading settings***

System settings can be saved to storage devices, or loaded from storage devices attached to the USB port by connecting the USB storage device and touching the Save Settings or Load Settings button.

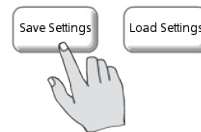

## Encoders screen

The Encoders screen contains data and choice fields for specifying encoder resolution, units of measure, encoder type, reference marks and other critical encoder parameters for each measurement axis.

### Selecting an axis to configure

Selections are made by repeatedly touching the Axis choice field to cycle through all the available measurement axes.

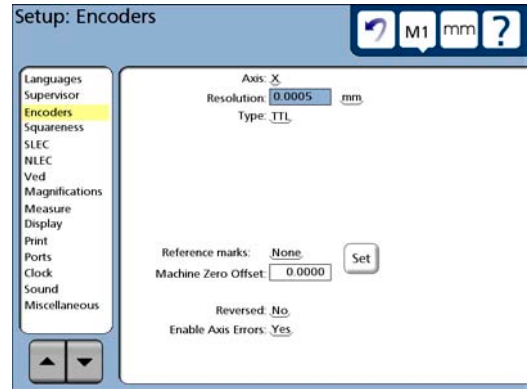

In this example, the measurement axis choices (X, Y and Z) are cycled by repeatedly touching the Axis choice field.

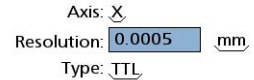
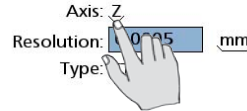
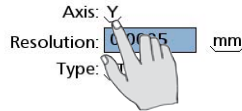
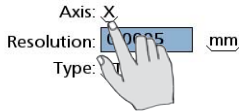

### Specifying encoder resolution

Encoder resolution is entered into the Resolution data field using the numeric keys on the front panel.

### Specifying encoder type

Encoder type is toggled between TTL and Analog by touching the Type choice field.

Type: TTL

Type: Analog



## Selecting reference marks

Selections are made by repeatedly touching the Reference marks choice field to cycle through all the available encoder reference mark types.

In this example, the reference mark choices (None, Manual, Single and Absolute) are cycled by repeatedly touching the Axis choice field.

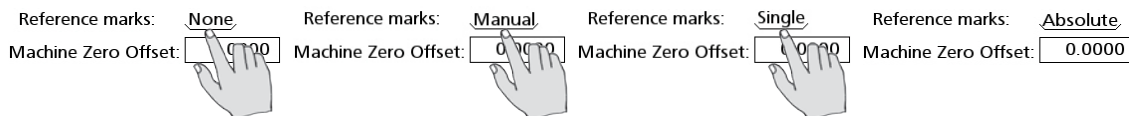

### None

No encoder reference marks are used. Machine zero will be established at the encoder locations encountered when the system is powered on. The machine zero location can be changed at any time using the Machine Zero Set function described later in this chapter.

### Manual

You will be prompted to move the stage to position the encoders at a point that you wish to use as machine zero each time the system is powered. The manual reference mark selection is commonly used with “hard stop” machine references. The machine zero location can be changed at any time using the Machine Zero Set function described later in this chapter.

### Single

You will be prompted to move the stage to cross encoder reference marks on each axis each time the system is powered. The reference mark crossing points of each encoder are used to determine the machine zero position. The machine zero location can be changed at any time using the Machine Zero Set function described later in this chapter.

### Absolute

Selecting Absolute reference marks causes a Teach button to be displayed. Touch the Teach button to initiate a process that will guide you through the steps required to cross encoder reference marks. Follow the instructions provided on the screen. You will be prompted to move the stage to cross reference marks on each axis. The reference mark crossing points of each encoder are used to determine the machine zero position. Sometimes the resulting machine zero position for absolute reference marks can be located outside the stage boundaries. In these cases, this machine zero location can be changed by the user to a more convenient “home” position for measurements using the Machine Zero Set function described on the next page.

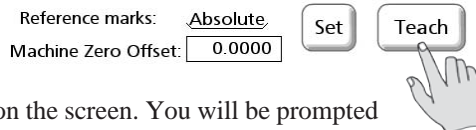

### Setting a new machine zero reference

A machine zero is established each time the QC-300 is powered. However, it might be necessary or convenient to change the location of the machine zero position to a new “home” position for measurements. To set a new machine zero position:

Select the Machine Zero Offset data field, move the stage to the desired new machine zero position and touch the Set button. The new machine zero for the current axis will be established and the offset displacement from the original machine zero to the new machine zero will be shown in the Machine Zero Offset data field. Repeat this process for each axis.

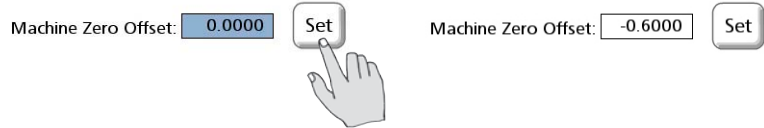

#### CAUTION

**SLEC and NLEC encoder error correction values are referred to a repeatable machine zero location. If the machine zero location is set to a different XY position, SLEC and NLEC correction values will no longer be valid.**

### Reversing the encoder count direction

Encoder count direction for each axis is toggled between normal and reversed by repeatedly touching the Reversed choice field.

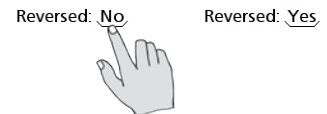

### Enabling axis error messages

Encoder error messages for each axis can be displayed on the LCD. These messages are enabled or disabled by repeatedly touching the Enable Axis Errors choice field.

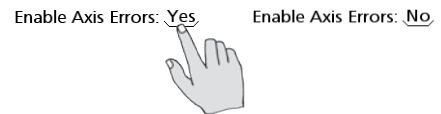

## Squareness screen

The Squareness screen contains data and choice fields for calibrating the squareness of the measuring system. The calibration of stage squareness requires the use of a certified square artifact. To calibrate squareness:

- 1 Place the square calibration artifact on the stage with one edge along the X-axis.
- 2 Measure the angle of the square calibration artifact (ideally 90 degrees).

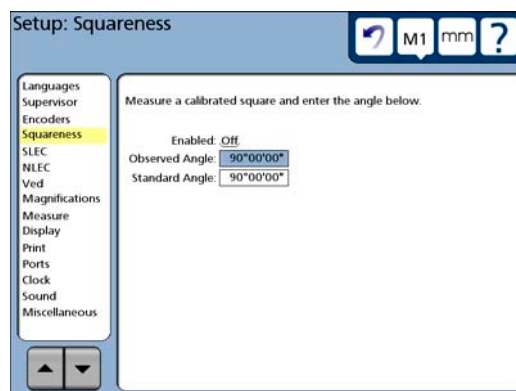

- 3 Select the Observed Angle data field, enter the measured angle using the number keys and press the Enter key to highlight the Standard Angle field.

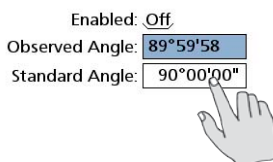

- 4 Enter the actual angle of the square calibration artifact obtained from the artifact's certification document into the Standard Angle data field.

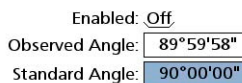

- 5 Touch the Enabled choice field to toggle the field to ON.

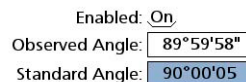
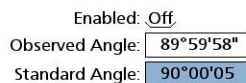
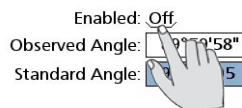

## SLEC screen

The SLEC screen contains fields for enabling and configuring linear error correction (LEC) or segmented linear error correction (SLEC) for each encoder axis.

### ***LEC or SLEC, which is right for my application?***

Any channel input device can include slight nonlinearities over its measurement range. LEC compensates for nonlinearities by applying a single linear correction value to the entire range of measurement. SLEC compensates for nonlinearities by applying correction values to the individual nonlinear segments of the measurement range.

LEC is the easiest error correction to set up, but does not provide correction for individual nonlinearities that could be present over small portions of the entire range. SLEC error correction can result in more accurate measurements, but requires more time and effort to set up.

If an overall nonlinearity exists without significant individual errors across the scale, LEC can be applied as an overall correction method. However, if an encoder is thought to have significant individual nonlinearities across the range of measurement, SLEC should be applied as the correction method.

### ***LEC (Linear error correction)***

LEC compensates for encoder nonlinearities by applying a single linear correction value to the entire range of measurement. The procedure for configuring the LEC error correction is diagrammed and explained below.

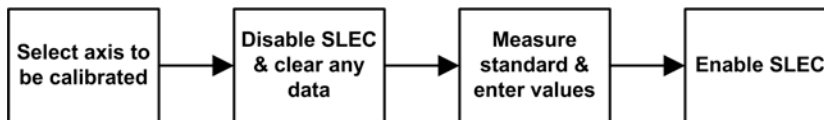

- 1 Touch the SLEC menu item and then touch the Axis choice field repeatedly to cycle to the desired axis.

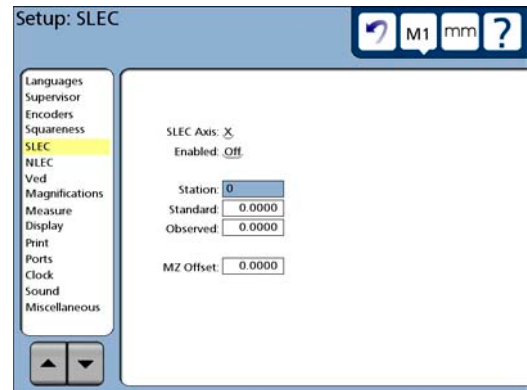
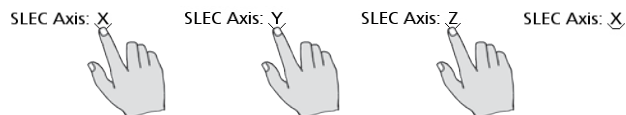

2 Make sure the Enabled choice field is toggled to Off, and erase any existing data in all the data fields using the methods described earlier in this chapter. Station 0 should be displayed with zeros in the Standard, Observed and MZ Offset fields when this step is complete.

Enabled: On      Enabled: Off



SLEC Axis: X  
Enabled: Off

Station:   
Standard:   
Observed:

MZ Offset:

3 The length of the calibration standard should cover as much of the axis range of motion as possible. Measure the standard and enter the Standard (certified) and Observed (measured) values into the corresponding data fields.

SLEC Axis: X  
Enabled: Off

Station:   
Standard:   
Observed:

MZ Offset:

4 Touch the Enabled choice field to toggle error correction On.

Enabled: Off      Enabled: On



## SLEC (Segmented linear error correction)

SLEC compensates for encoder non-linearities by applying correction values to individual nonlinear segments. These SLEC correction values are created by the QC-300 system using data provided by the user in the SLEC Setup screen. The SLEC setup data provided by the user consists of Standard (certified) and Observed (measured) values of a standard, or standards that cover the entire range of axis motion.

The SLEC measurements can divide the axis range of motion into up to 150 segments. The example diagrammed on the next page shows standard values compared to observed values for 6 segments. The deviation (difference between standard and observed) is also shown. Segments are defined as any straight line on the graph of deviations, beginning with segment zero.

The standard and observed values at the end of each segment are entered as data for a station in the SLEC Setup screen. For example, the standard and observed values at the end of segment 0 on the diagram are 40 and 40, and are entered into the Standard and Observed data fields for station 1.

When the procedure is complete and setup data are entered, correction values will be calculated for the encoder based on the standard and observed values at the end of the segments. The procedure for configuring the SLEC error correction is diagrammed and explained below.

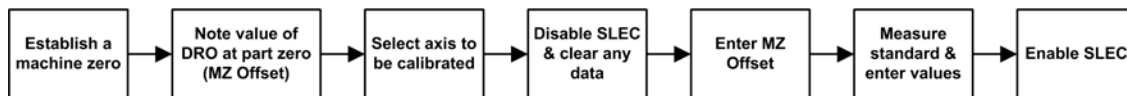

1 Cycle the power to establish a repeatable machine zero. You will be prompted to move the encoders to cross reference marks or perform a hard stop to the establish machine zero. Perform the machine zero operation.



### NOTE

**If a hard stop zero is performed, the same stop will be required each time the QC-300 is started.**

2 The length of the calibration standard should cover as much of the range of axis motion as possible. Move the stage to position the encoder of the axis being calibrated at the beginning (part zero position) of the calibration standard. Make a note of this calibration axis value shown in the DRO; this will be entered later as the machine zero (MZ) Offset.

3 Access the setup menu, touch the SLEC menu item and then touch the Axis choice field repeatedly to cycle to the axis that will be calibrated.

SLEC Axis: X



SLEC Axis: Y



SLEC Axis: Z



SLEC Axis: X



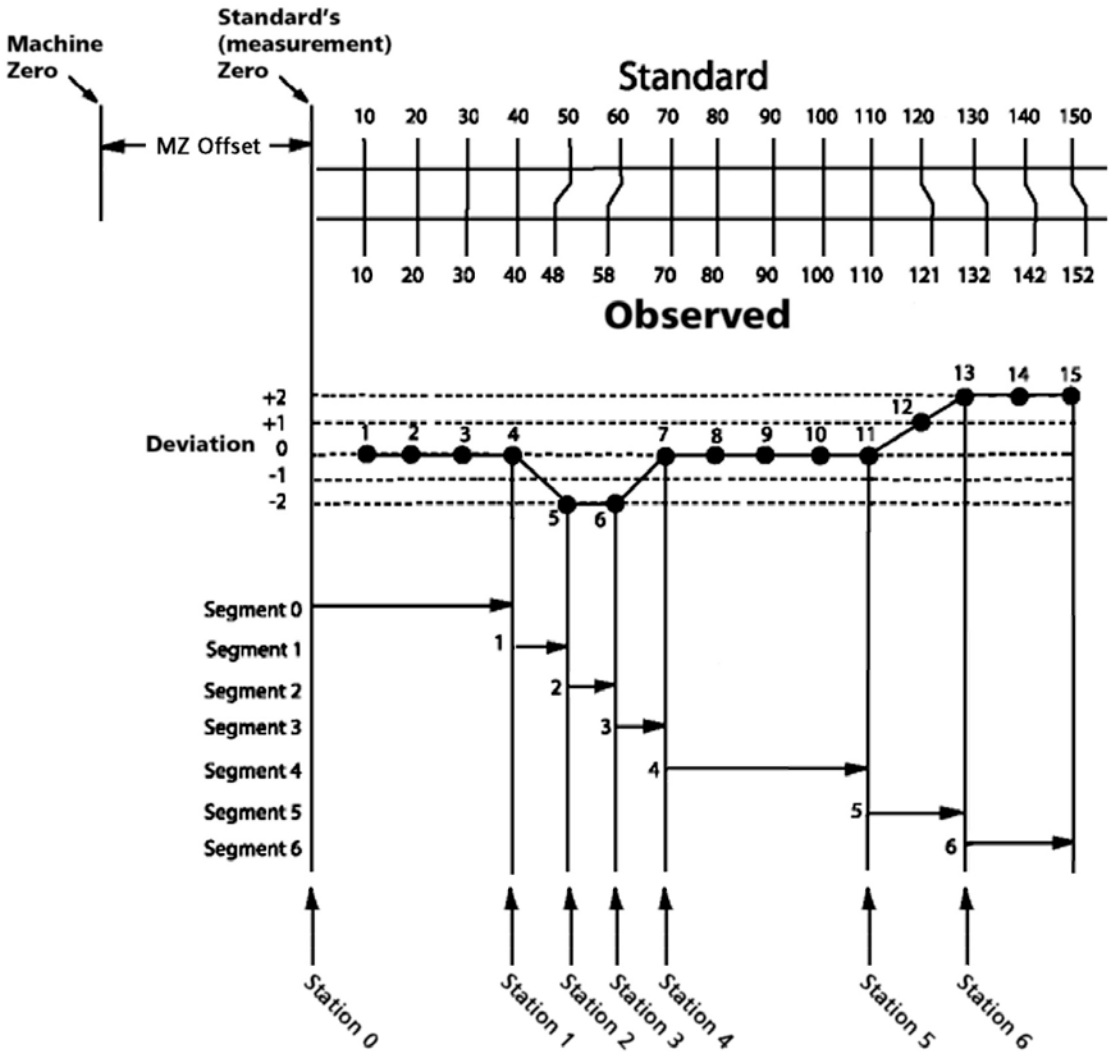

4 Make sure the Enabled choice field is toggled to Off, and erase any existing data in all the data fields using the methods described earlier in this chapter. Station 0 should be displayed with zeros in the Standard, Observed and MZ Offset fields when this step is complete.

Enabled: On      Enabled: Off



SLEC Axis: X  
Enabled: Off

Station:	0
Standard:	0.0000
Observed:	0.0000
MZ Offset:	0.0000

5 Enter the MZ Offset value noted earlier in step 2.

SLEC Axis:  X  
Enabled:  Off

6 Zero the DRO for the axis being calibrated at the part zero position of the standard and enter zeros into the Standard and Observed data fields for Station zero.

Station:   
Standard:   
Observed:

MZ Offset:

7 Measure the standard, incrementing the Station number and entering the Standard (certified) and Observed (measured) values into the corresponding data fields for each segment.

This example shows measurements across 150 mm on the X-axis, and the SLEC screens for entering the six segments of standard and observed data to provide error correction.

**Reminder**

Segments are straight lines on the deviation graph. Only the beginning and end points of each straight line segments must be entered into SLEC data fields.

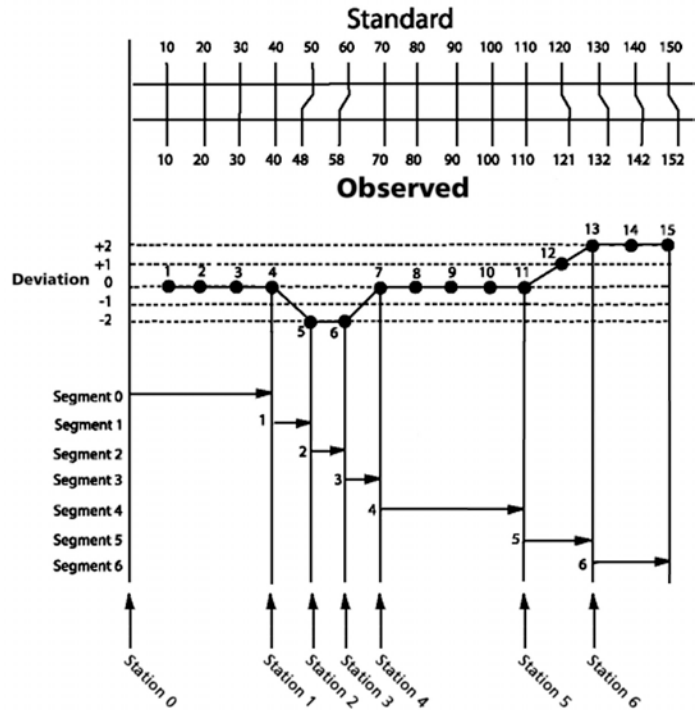

SLEC Axis:  X  
Enabled:  Off

Station:   
Standard:   
Observed:

MZ Offset:

**Station 1 of 6**

SLEC Axis:  X  
Enabled:  Off

Station:   
Standard:   
Observed:

MZ Offset:

**Station 2 of 6**

SLEC Axis:  X  
Enabled:  Off

Station:   
Standard:   
Observed:

MZ Offset:

**Station 3 of 6**

SLEC Axis:  X  
Enabled:  Off

Station:   
Standard:   
Observed:

MZ Offset:

**Station 4 of 6**

SLEC Axis:  X  
Enabled:  Off

Station:   
Standard:   
Observed:

MZ Offset:

**Station 5 of 6**

SLEC Axis:  X  
Enabled:  Off

Station:   
Standard:   
Observed:

MZ Offset:

**Station 6 of 6**

8 Touch the Enabled choice field to toggle it On.

SLEC Axis:  X  
Enabled:  On

Station:   
Standard:   
Observed:

MZ Offset:

## VED screen

The VED screen contains fields for specifying edge detection and auto-enter parameters, setting user permissions for zeroing axes on the video DRO and for performing video magnification and camera skew calibrations.

### Specifying minimum probed points

The number of points to be collected for a circle, arc or line is specified by the user in the probe pop-up screen discussed in [Chapter 5: Probes](#). When the number of points actually collected falls below the required percentage of the number specified in the probe pop-up screen, a “Failed measurement” error message is displayed and the measurement is aborted. To specify the required percentage of points, touch the Probe Points Requirement data field and enter the desired percentage using the number keys.

Probe Points Requirement  Probe Points Requirement  %



### Specifying light settling time

When a lighting level is changed during the execution of a program, a settling time is included that allows the new light level to become stable. To change this settling time, touch the Light Step Delay data field and enter the new time in milliseconds using the number keys.

Light Step Delay  Light Step Delay



### Specifying contrast threshold

Screen contrast is a combination of the illumination difference between adjacent light and dark regions on the screen and the sharpness of the transition from light to dark. Perfect contrast could be loosely described as very light and very dark regions that meet at a very sharp transition. The contrast threshold is expressed as a percentage of perfect contrast and defines the minimum contrast required for video edge detection.

The contrast threshold value can be specified by touching the contrast threshold data field and entering a percentage, or by touching and sliding the yellow arrow up or down the contrast bar on the right side of the LCD.

Contrast Threshold  Contrast Threshold



#### NOTE

The contrast threshold cannot be changed on the LCD when Lock Contrast Threshold is set to Yes on this screen as described later in this section.

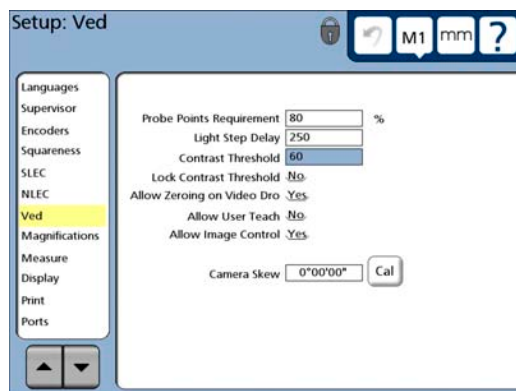

### Locking the contrast threshold

When the contrast threshold adjustment is unlocked, the user can change the contrast threshold requirement for edge detection by touching and sliding the yellow arrow up or down the contrast bar on the right side of the LCD. Locking the contrast threshold prevents users from adjusting the contrast threshold on the LCD screen.

To lock the contrast threshold, touch the Lock Contrast Threshold choice field to toggle the choice to Yes.

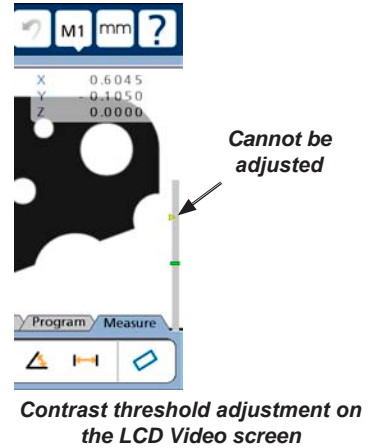
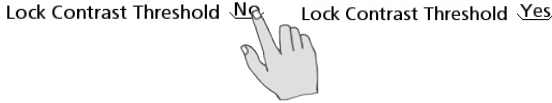

### Enabling axis-zeroing on the video DRO

Measurement axes can be zeroed from the DRO screen at any time by touching an axis Zero button.

As a convenience to the user, the small video DRO display can also be configured to include axis zero bars on the LCD video screen.

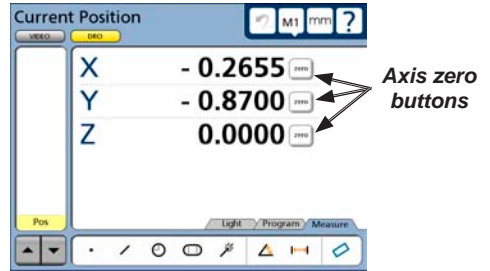
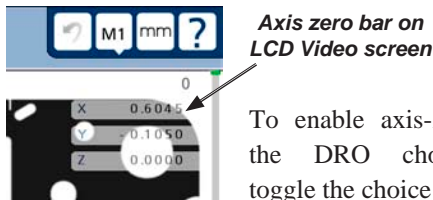

To enable axis-zeroing from the video DRO, touch the Allow Zeroing on the DRO choice field to toggle the choice to Yes.

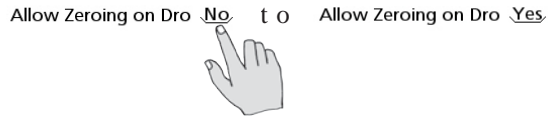

### Enabling user access to magnification calibrations

Normally, video magnification calibrations are performed by supervisors, distributors and OEMs. However, the magnification calibration tools located on the Magnification setup screen can also be made available to users.

Touch the Allow User Teach choice field to toggle the choice to Yes to provide user access to the calibration tools.

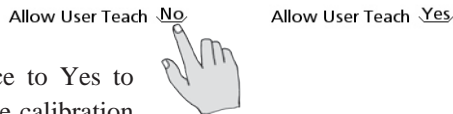

### Magnification calibration tools

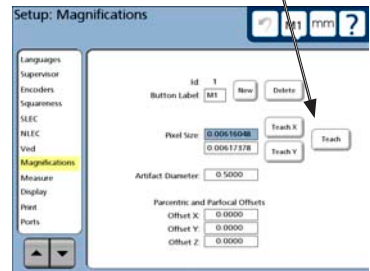

Magnification setup screen

## Displaying image controls

Image controls can be displayed in addition to the light adjustment tools for optimizing the video image for measurement. The image controls can be used to adjust the contrast and brightness of the image. Light and Image control tools can be alternately shown by repeatedly touching the Light/Image tab.

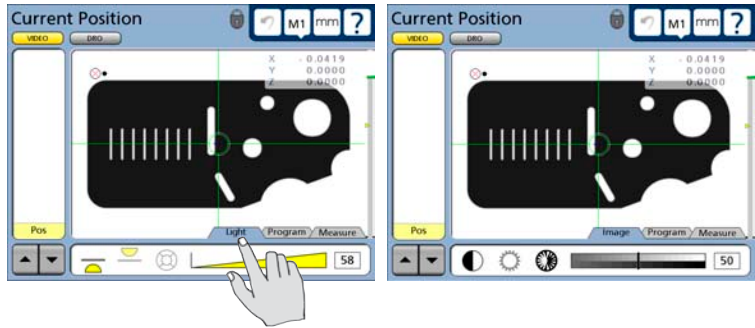

Touch the Allow Image Control choice field to toggle image controls between enabled and disabled.

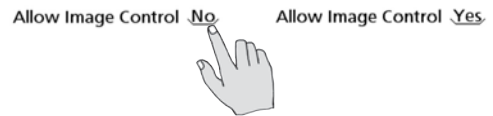

## Performing camera skew calibrations

Small amounts of rotational camera misalignment exists in most camera mounting systems. The camera skew calibration measures this misalignment and applies a skew compensation to subsequent measurements to eliminate the effect of rotational misalignments.

To perform a camera skew calibration:

- 1 Touch the Magnification button to cycle to the lowest magnification.
- 2 Touch the CAL button.

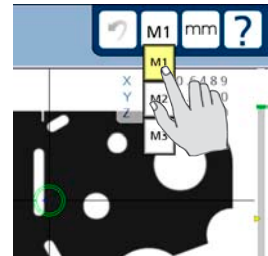
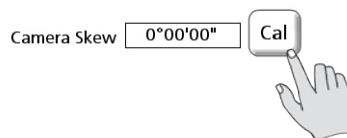

- 3 The video screen will be displayed with instructions for performing the calibration. Follow the instructions to complete the calibration.



### NOTE

Systems should be aligned mechanically to within a few degrees. This calibration is not intended as a substitute for good mechanical alignment.

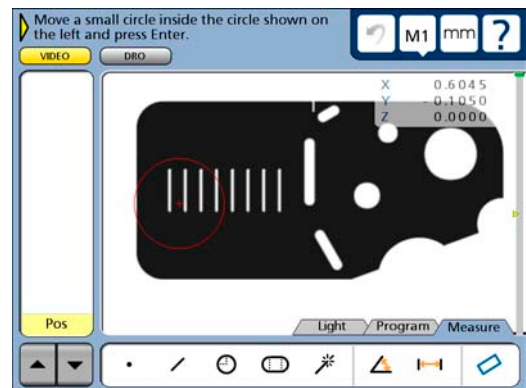

## Magnifications screen

The magnifications screen contains fields and tools for adding and deleting video magnifications, calibrating video pixel size, and performing video parcentric and parfocal calibrations.

### Adding video magnifications

To add a video magnification, touch the New button. The next higher ID number and default button label will be added.

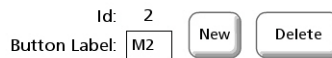
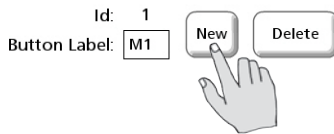
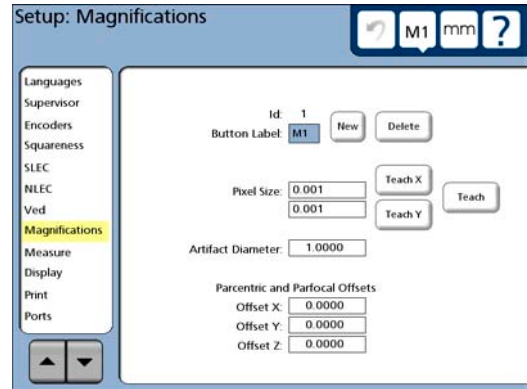

The button label can be changed to any three digit alphanumeric character string by touching the Button Label data field and deleting or entering characters using the keyboard screen or the front panel keys.

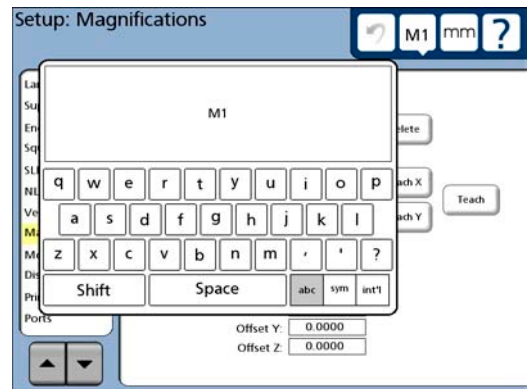
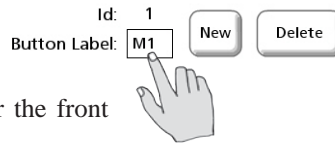

Use the Cancel key to delete characters. Use the Finish key to complete and store the new label. The pixel size of the new video magnifications must be calibrated before using the magnifications in measurements.

### Deleting video magnifications

To delete a magnification, touch the Magnification button, select the magnification to be deleted, and then touch the Delete button.

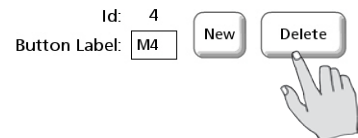
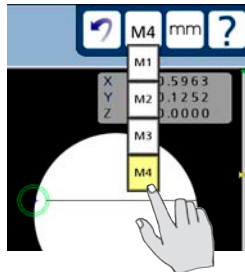

### Calibrating video magnification pixel size

The pixel size of each video magnification must be calibrated before conducting measurements. Pixel sizes are calibrated by measuring a circle artifact of known diameter using the Teach function, or by measuring a straight edge using the Teach X and Teach Y functions.

#### Calibrating with a circle artifact

To calibrate pixel size using a circle artifact:

- 1 Select the desired magnification by touching the Magnification button or by touching the ID number field.
- 2 Touch the Artifact Diameter data field and enter the known circle artifact diameter using the number keys.

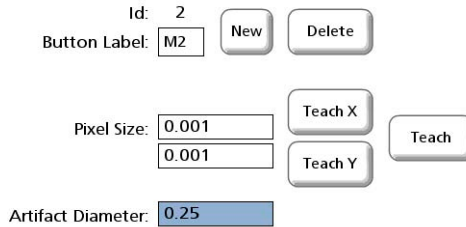
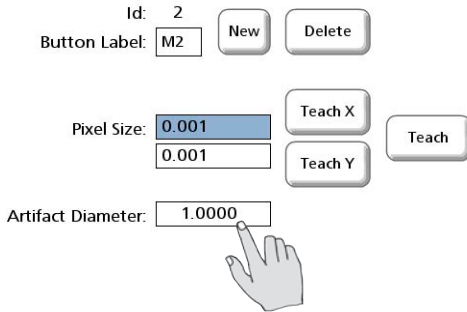
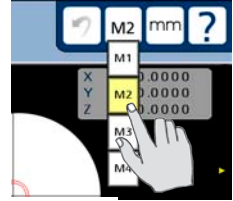

- 3 Touch the Teach button. The video screen will be shown with instructions for measuring the circle artifact.

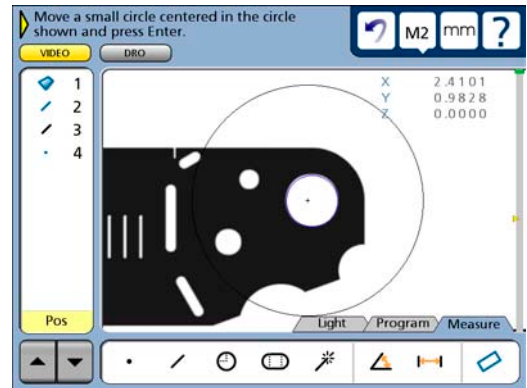
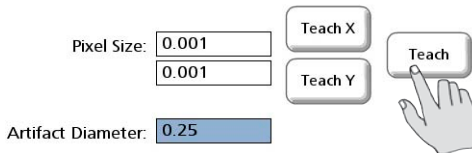

- 4 Follow the instructions provided on the screen to position and measure the circle. The X and Y pixel sizes will be displayed in the Pixel Size data fields.

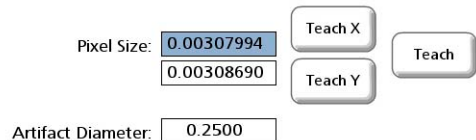

### Calibrating with a straight edge

To calibrate pixel size using a straight edge or line:

1 Select the desired magnification by touching the Magnification button or by touching the ID number field.

2 Touch the Teach X button. The video screen will be shown with instructions for measuring a straight edge on the x-axis.

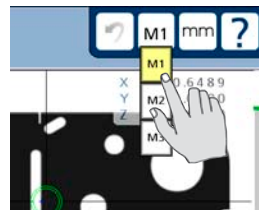
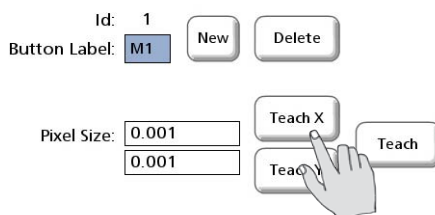

3 Follow the instructions to position and measure the edge on both sides of the x-axis. The x-axis pixel size will be displayed in the X pixel size data field.

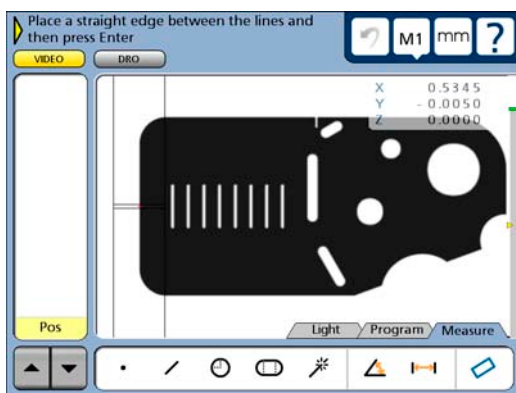

Measure a vertical edge on the left and...

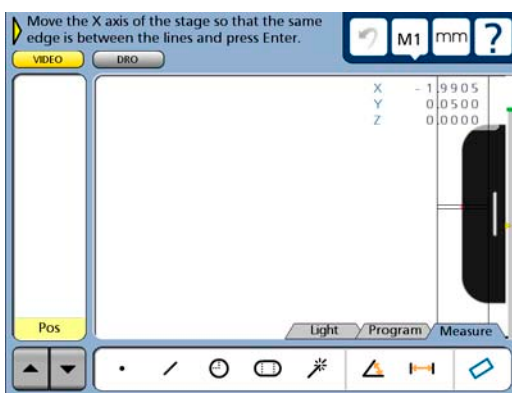

on the right side of the screen

4 Touch the Teach Y button. The video screen will be shown with instructions for measuring a straight edge on the y-axis.

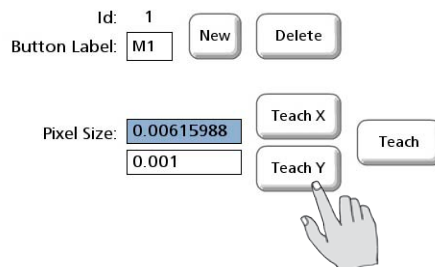



- 5 Follow the instructions to position and measure the edge on the top and bottom of the y-axis. The y-axis pixel size will be displayed in the Y pixel size data field.

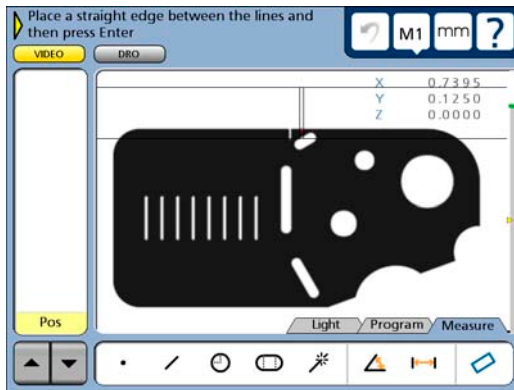

*Measure a horizontal edge on the top and...*

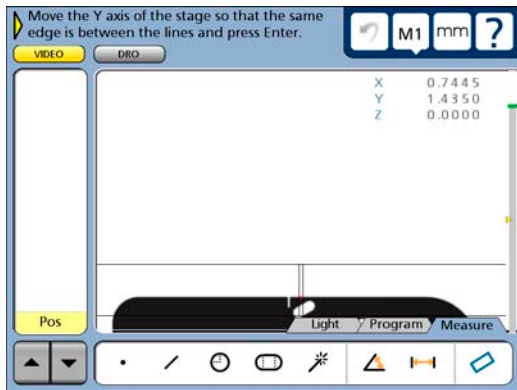

*on the bottom of the screen*

## Performing video parcentric and parfocal calibrations

Parcentric calibration eliminates X and Y axis measurement offset errors that can occur when changing video magnifications. Parfocal calibration eliminates z-axis measurement offset errors that can occur when the video focus is adjusted when changing magnifications.



### NOTES

As shown in the essential setup requirement diagram earlier in this chapter, camera skew calibration, squareness calibration and error correction must be performed prior to this process.

As shown in the diagram on the right, leveling, establishing a datum and measuring a circle are required steps in this procedure. Refer to **Chapter 6: Measuring** for details regarding these activities if necessary.

Parcentric and parfocal calibrations are performed simultaneously using a single circle artifact in the calibration process diagrammed at the right and described below. To perform parcentric and parfocal calibrations:

1 Zero any existing Parcentric and Parfocal X, Y and Z offsets by selecting each magnification and entering zero values into the Offset X, Offset Y, and Offset Z data fields.

#### Parcentric and Parfocal Offsets

Offset X:	0.0000
Offset Y:	0.0000
Offset Z:	0.0000

**Zero all offsets**

2 Select the highest video magnification. In this example, M1 happens to be the highest magnification. Your system might be different.

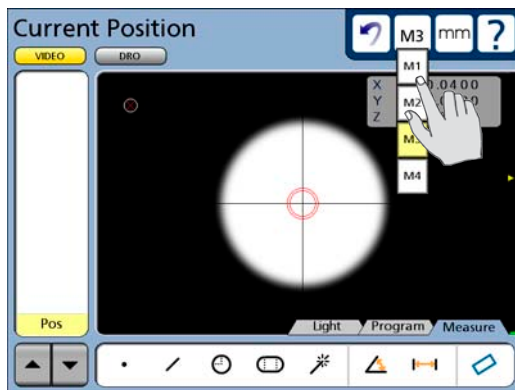

**Select the highest magnification**

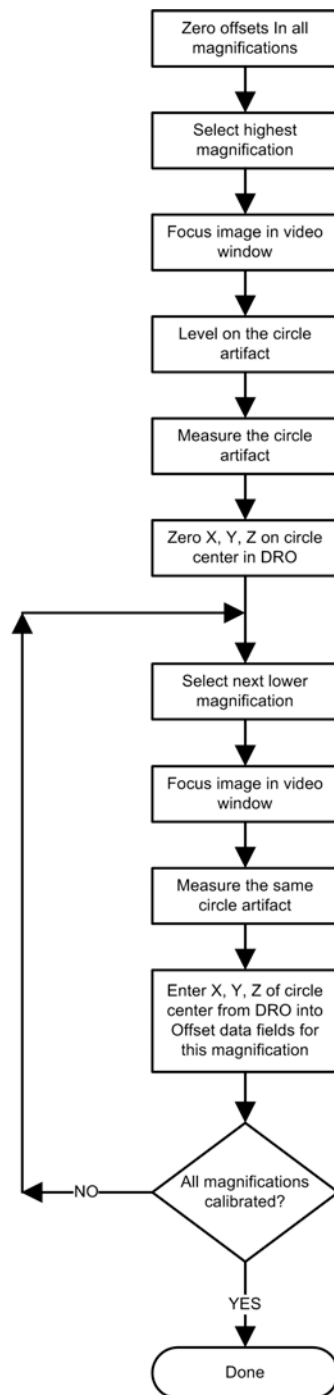

- 3 Focus the circle artifact image in the video window using the video camera focus adjustment.

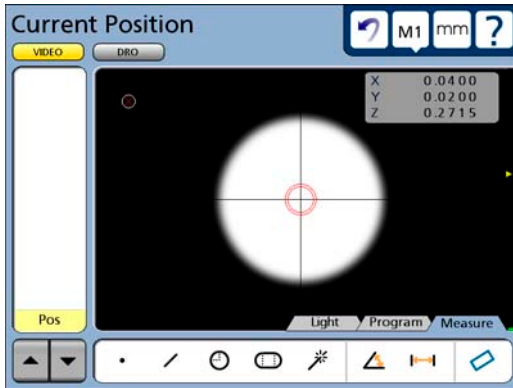

*Focus the circle artifact image...*

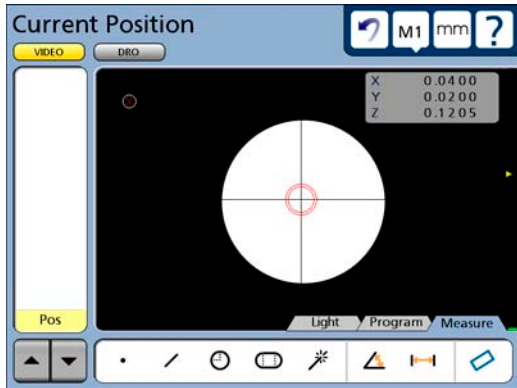

*using the camera focus adjustment*

- 4 Perform a level measurement using the circle artifact. The level measurement will zero the z-axis at the highest video magnification.

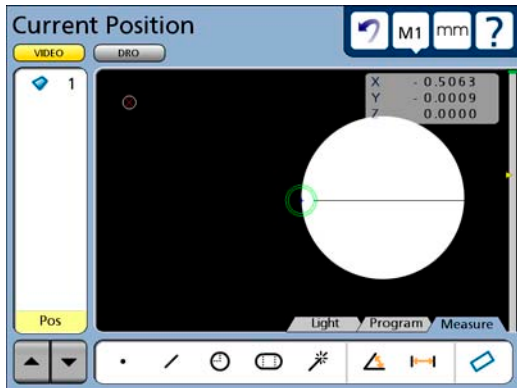

- 5 Measure the circle artifact and create a zero datum point at the center of the circle feature in the DRO screen. This will zero the X and Y axes at the center of the circle. Subsequent measurements of this circle artifact at other magnifications will result in X, Y and Z axis offsets with respect to this magnification. These offsets will be entered into the Magnification setup screen for each corresponding magnification.

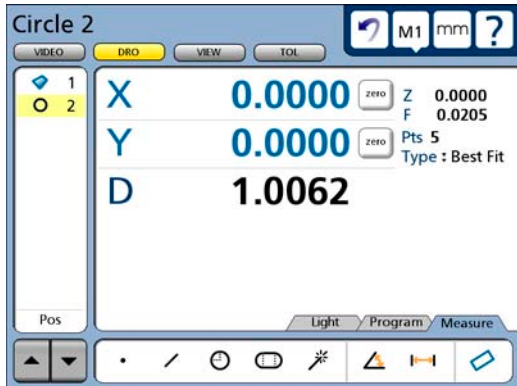

6 Select the next lower magnification. This is M2 in this example.

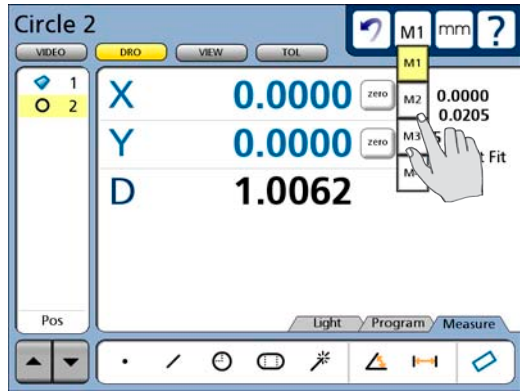

7 Focus the circle artifact image in the video window at the new magnification.

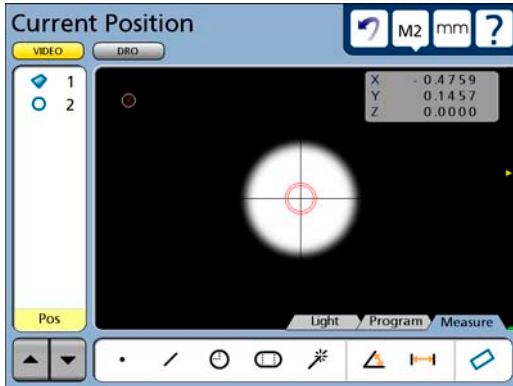

*Focus the circle artifact image...*

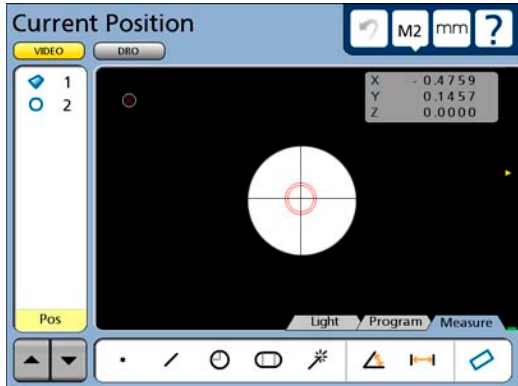

*at the new magnification*

8 Measure the circle artifact at the new magnification.

9 Enter the X,Y and Z positions of the new circle feature shown in the DRO into the Offset X, Offset Y and Offset Z fields of the Magnification setup screen.

Parcentric and Parfocal Offsets

Offset X:

Offset Y:

Offset Z:

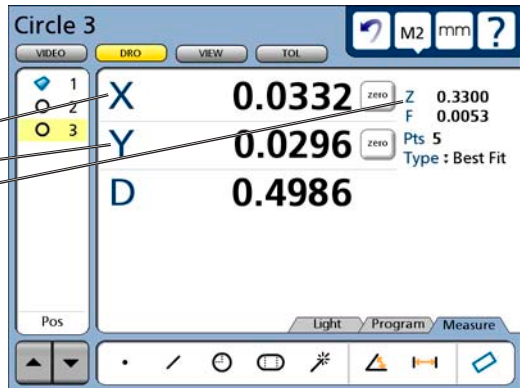

10 Repeat steps 6 through 9 for the remaining video magnifications.

## Measure screen

The Measure screen contains fields for specifying the method of data point collection, specifying the minimum number of points required to measure different geometries, enabling feature retention, locking the reference frame, selecting distance presentations and forcing a startup zero sequence upon powering the instrument.

## Annotation

The annotation type defines the method of data point collection. The annotation choice field can be toggled between Backward and Forward types.

Backward annotation imposes no limit on the number of data points that can be collected by the user when measuring a feature. For example, when backward annotation is used, a circle can be measured with as few as the minimum number of points shown in the Min Circle data field, or as many as the user wishes to collect up to a maximum of 99 points. When backward annotation is used, the user must press the Finish key to complete the measurement and store measurement data in the feature list.

Forward annotation limits the number of data points collected in a feature measurement to the minimum shown in the corresponding Min data field. For example, when forward annotation is used and the Min Circle value is 3, the circle measurement will automatically be completed when 3 points have been collected. No user interaction will be required to store the measurement data in the feature list.

Touch the Annotation choice field to toggle the choice between Backward and Forward annotation.

Annotation: Backward

Annotation: Forward



## Minimum points required for a feature measurement

Each feature type is given a minimum data point requirement. The default minimums are the geometric minimums necessary to define the corresponding feature type. For example, a minimum of 3 points is required to define a circle, 2 for a line and 1 for a point. The minimum number required by the system can be increased (up to 99) to improve the accuracy of measurements. This is most useful when Forward annotation is used and the measurement data are automatically limited to the specified minimum.

To define the minimum data points required by the system to complete a feature measurement, touch the corresponding Min data field and enter the desired minimum number using the number keys.

Min Point: <input type="text" value="1"/>	Min Point: <input type="text" value="1"/>
Min Line: <input type="text" value="2"/>	Min Line: <input type="text" value="2"/>
Min Circle: <input type="text" value="3"/>	Min Circle: <input type="text" value="8"/>
Min Arc: <input type="text" value="3"/>	Min Arc: <input type="text" value="3"/>
Min Level: <input type="text" value="3"/>	Min Level: <input type="text" value="3"/>
Min Skew: <input type="text" value="2"/>	Min Skew: <input type="text" value="2"/>

### ***Retaining feature data through a power cycle***

The system can be configured to retain feature data in the feature list through a power cycle, or to erase all feature data when the power is turned off.

To retain feature data through a power cycle, touch the Retain Features choice field to toggle the choice to Yes.

Retain features: No

Retain features: Yes



### ***Locking features to their original datums***

Features can be locked to their original datums or can be referred to new datums as datums are created. In the following example illustrating locked and unlocked features, 6 features are measured using 2 datums.

#### ***Measurement activity***

Datum 1 is created, then  
 Feature 1 is measured  
 Feature 2 is measured  
 Feature 3 is measured

Datum 2 is created, then  
 Feature 4 is measured  
 Feature 5 is measured  
 Feature 6 is measured

#### ***Measurement results when features were locked before measurements***

Features 1-3 are referred to datum 1  
 Features 4-6 are referred to datum 2

#### ***Measurement results when features were not locked before measurements***

Features 1-6 are referred to datum 2

To lock features to their original datums, touch the Lock Features choice field to toggle the choice to Yes.

Lock Features: No

Lock Features: Yes



### Specifying signed distances

Distance measurements result in X, Y and L (vector) displacements. The Y-axis displacements can be shown as signed or absolute (positive only) values. When signed values are specified, axis displacements from right to left and from top to bottom are negative.

To specify signed distances, touch the Distances choice field to toggle the choice to Signed.

Distances: Absolute

Distances: Signed



### Startup zero

The QC-300 can prompt the user to establish a machine zero position when the power is applied to the instrument.

To require a startup zero, touch the Startup Zero choice field to toggle the choice to Yes.

Startup Zero: No

Startup Zero: Yes



## Display screen

The Display screen contains fields for configuring display resolution and other LCD display parameters.

### Display resolution

The display resolution fields are used to specify the resolution of measurements shown on the DRO and other screens. Displayed numbers will be rounded as the display resolution is decreased below that of the input. The table below illustrates how the display is governed by the display resolution setting.

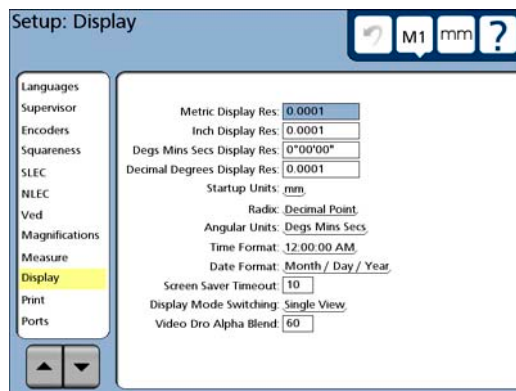

Encoder input	Display resolution	Displayed value
1.567	0.0001	1.5670
1.567	0.001	1.567
1.567	0.01	1.57
1.567	0.1	1.6
1.567	1	2



#### NOTE

**Display resolution should never be higher than the encoder resolution. Specifying display resolutions that are higher than encoder resolutions can lead to misleading displays of values.**

To specify display resolution, touch the data field of the desired Display category and enter the desired resolution using the number keys.

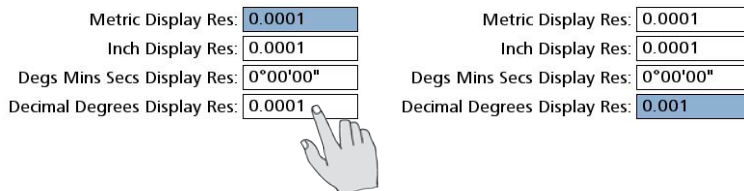



### Default units of linear measure

The Startup Units field is used to specify the default display of linear measurements when power is applied to the system. These display settings can be changed temporarily but will revert to the startup defaults when the power is cycled.

To select startup units of linear measure, touch the Startup Units choice field to toggle between Inch and mm.

Startup Units: inchStartup Units: mm

### Radix for numeric displays

The Radix choice field is used to specify the radix displayed in numeric fields. Touch the Radix choice field to toggle between Decimal Point (1.0) and Comma (1,0).

Radix: Decimal PointRadix: Comma

### Angular units of measure

The Angular Units choice field is used to specify the display of angular units of measurement. The display choice can be toggled between degrees, minutes and seconds or in decimal degrees and will be retained across power cycles.

Touch the Angular Units choice field to toggle between degrees, minutes and seconds and decimal degrees.

Angular Units: Degs Mins SecsAngular Units: Decimal Degrees

### Time formats

The Time Format choice field is used to specify the display of time. The display choice can be toggled between 12 hour and 24 hour formats and will be retained across power cycles.

Touch the Time Format choice field to toggle between 12 hour and 24 hour formats.

Time Format: 12:00:00 AMTime Format: 24:00:00

### Date formats

The Date Format choice field is used to specify the display of date. The display choice can be toggled between Month/Day/Year and Day/Month/Year formats and will be retained across power cycles.

Touch the Time Format choice field to toggle between Month/Day/Year and Day/Month/Year formats.

Date Format: Month / Day / YearDate Format: Day / Month / Year

## Screen saver delay

The Screen Saver Timeout data field is used to specify the minutes of QC-300 inactivity before the LCD screen saver is displayed. The screensaver is disabled when 0 is entered into this field.

To specify the minutes of inactivity before displaying the screen saver, touch the Screen Saver Timeout data field and enter the desired delay using the number keys.

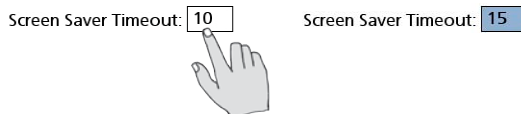

## Display mode switching

The QC-300 provides two display modes for measurements, Single View and Dual View.

In the Single View mode, the screen used for a measurement (DRO or Video) will be displayed again when the measurement is complete. However, when a measurement is initiated from the View or Tolerance screens, the Video screen will be used for the measurement in systems that include video capabilities.

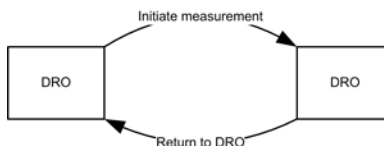
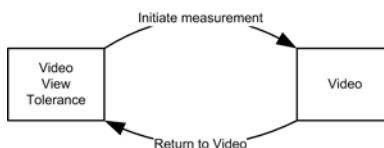

In the Dual View mode, the last screen used for a measurement (DRO or Video) will be used again for the current measurement. When the measurement is complete, the screen displayed before the measurement was initiated will be displayed again.

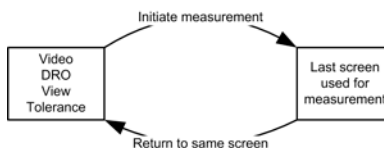

Touch the Display Mode Switching choice field to toggle the display mode between Single View and Dual View.

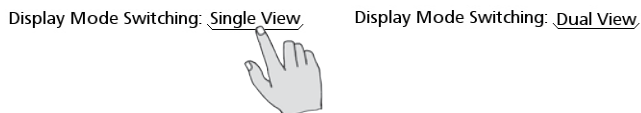

### Video DRO alpha blending

The opacity of the small video DRO can be adjusted to suit the preferences of the user. The adjustment can be in the range from 0% to 100% opacity.

Touch the Video DRO Alpha Blend data field and enter the desired opacity using the number keys.

Video Dro Alpha Blend:



Video Dro Alpha Blend:

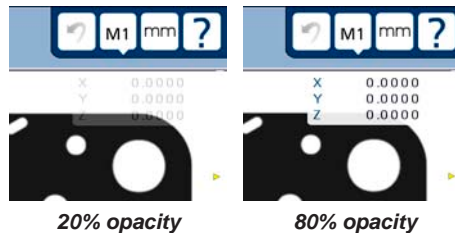

## Print screen

The Print screen contains fields for formatting printed reports and RS232 data streams of feature measurement data.

### Specifying a data type

The Print button initiates the transfer of data to the USB port for printing, or to the RS232 serial port for communication with a computer. Specify the type of data to be transmitted by repeatedly touching the Print Button choice field.

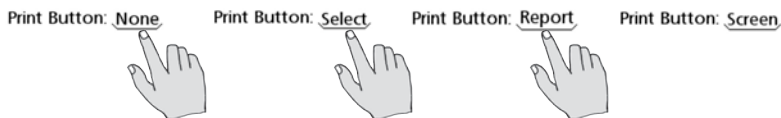
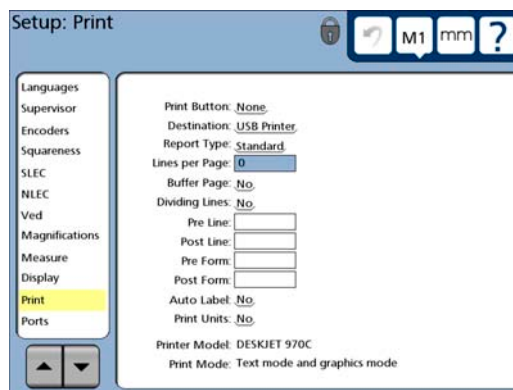

Data choices include:

- None No data will be printed or transmitted
- Select User will be prompted to select the data that will be printed or transmitted
- Report A standard report of all feature data or a tolerance report of only features that have tolerances applied will be printed or transmitted
- Screen Only the encoder values currently shown on the DRO screen (current position) will be printed or transmitted. Screen values can be printed or transmitted each time the print key is pressed, or can be buffered and printed or transmitted when an entire page of values is ready.

### Specifying a data destination

Feature measurement data can be sent to the USB port for printing, or to the RS232 serial port for transmission to a computer. Touch the Destination choice field to toggle between the USB and serial ports.



### Lines per page

Specify the length of printed report pages by touching the Lines per Page data field and entering the desired number of character lines using the number keys.

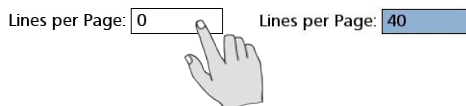

## Buffer page

When the current encoder positions shown on the DRO screen are specified in the Print Button field as the data printed or transmitted, the data can be transmitted each time the print key is pressed, or can be buffered and printed or transmitted when an entire page of values is ready. Touch the Buffer Page choice field to toggle a buffer page on or off.

Buffer Page: No      Buffer Page: Yes



## Specifying dividing lines

Dividing lines can be included between rows and columns of feature measurement data in printed reports and in transmitted data. Touch the Dividing Lines choice field to toggle a dividing lines on or off.

Dividing Lines: No      Dividing Lines: Yes



## RS232 control characters

Control characters can be added to the beginning and end of line and form data streams to accommodate the requirements of receiving systems and programs. To add RS232 control characters, touch the desired data field and enter the ASCII character number using the number keys. Use the decimal point key to separate ASCII characters.

Pre Line:   
 Post Line:   
 Pre Form:   
 Post Form:

Pre Line:   
 Post Line:   
 Pre Form:   
 Post Form:



### NOTE

An ASCII character chart is provided in [Chapter 9: Communication](#).

## Labeling axes on display printouts

When the data type specified for a port is “Display”, only the current axis positions shown on the DRO screen are printed. The axis values can be accompanied by an axis label letter by touching the Auto Label choice field and toggling it to Yes.

Auto Label: No      Auto Label: Yes



## Printing units of measure on reports

Units of measure can be included on printed reports by touching the Print Units choice field and toggling it to Yes.

Print Units: No      Print Units: Yes



## Parallel communication retries

The number of unsuccessful parallel communication attempts allowed can be specified by touching the Parallel Retry data field and entering the desired value.

Parallel Retry:

Parallel Retry:



## Ports screen

The ports screen contains fields for configuring the RS-232 serial communication port. The RS-232 communication port is used to send data to computers. RS-232 port settings can be changed to match those of the receiving system.

### Baud rate

Touch the Baud Rate choice field repeatedly to cycle to the desired serial data rate. Baud rates from 1,200 to 115,200 are available.

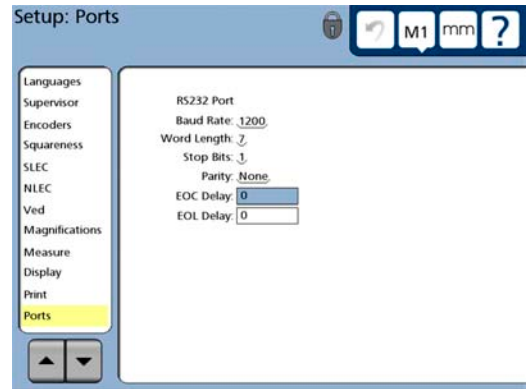

Baud Rate: 1200

Baud Rate: 115200



### Word length

Touch the Word Length choice field to toggle between data word lengths of 7 bits and 8 bits.

Word Length: 7

Word Length: 8



### Stop bits

Touch the Stop Bits choice field to toggle between 1 and 2 stop bits at the end of the data word.

Stop Bits: 1

Stop Bits: 2



### Parity

Touch the Parity choice field repeatedly to cycle to the desired parity error checking. Choices include None, Odd and Even.

Parity: None

Parity: Odd



### EOC delay

A delay can be inserted at the end of each character to satisfy the communication requirements of receiving systems. Touch the EOC data field and enter the desired delay in milliseconds using the number keys.

EOC Delay: 0

EOC Delay: 330



### EOL delay

A delay can be inserted at the end of each line of characters to satisfy the communication requirements of receiving systems. Touch the EOL data field and enter the desired delay in milliseconds using the number keys.

EOL Delay: 0

EOL Delay: 250



## Clock screen

The clock screen contains fields for setting the date and time included in data transmissions and printed on reports.

To change a date or time value, touch the desired data field and enter the value using the number keys

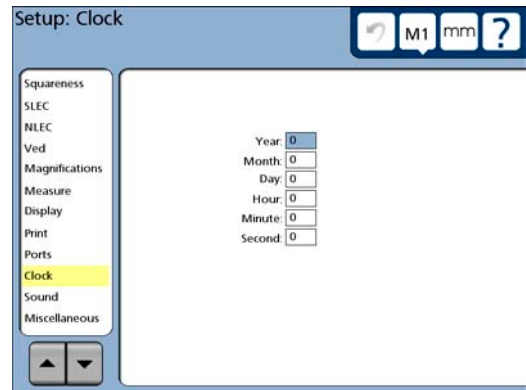
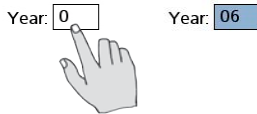

## Sound screen

A sound can be generated by the system to call attention to point entries. The sound is generated each time the Enter button is pressed to enter a point as part of a measurement.

Touch the Volume data field and enter a number to adjust the loudness of all sounds from 1 (very soft) to 10 (loud). Enter a zero to mute all sounds.

Volume:



Volume:

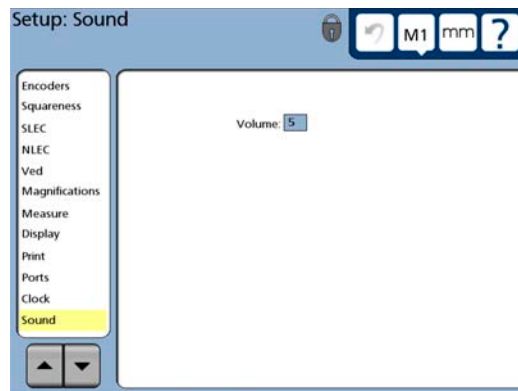



## Miscellaneous screen

The miscellaneous screen contains fields for calibrating and configuring the LCD touchscreen.

### Return to DRO threshold

The display automatically switches to display current position on the DRO from the View, Tolerance or DRO screens when the stage movement reaches or exceeds the DRO threshold value.

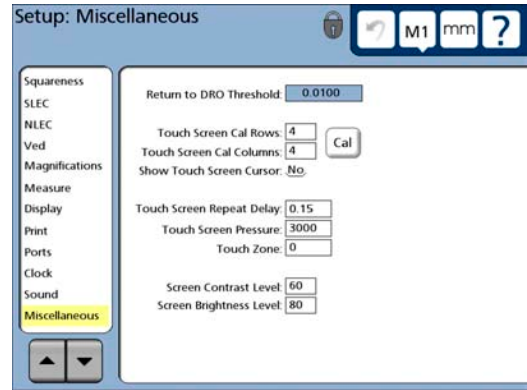

Touch the Return to DRO Threshold data field and enter the desired stage threshold motion using the number keys.

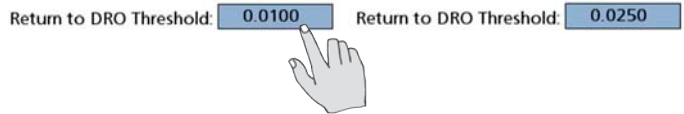

**NOTE**  
Entering a zero disables this function.

### Touchscreen calibration rows and columns

Touchscreen calibration measures touch-pressure at points displayed on a matrix of rows and columns. The number of touch-points included in the calibration is defined by specifying the number of rows and columns in the matrix. An example of a 4-row, 4-column matrix is shown at the right.



Touch the Touchscreen Cal Rows or Touchscreen Cal Columns data field and enter the desired value using the number keys.

*Example of a 4 X 4 calibration matrix*

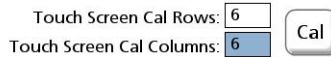
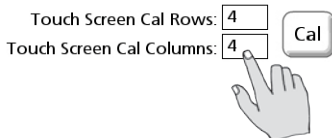

## Calibrating the touchscreen

The touch-pressure of the touchscreen should be calibrated as part of the initial setup and when a new operator begins using the system. To calibrate the touchscreen:

- 1 Confirm that the number of calibration rows and columns provide adequate touch-points to satisfy typical use requirements. Increase or decrease them if desired as described above.
- 2 Touch the Cal button. The first point of the calibration matrix will be displayed.

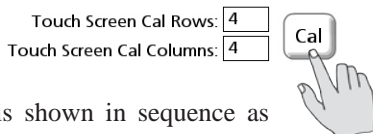

Each touch-point is shown in sequence as an x on the screen. Follow the instructions provided on the screen and then press the Finish key to complete the calibration. The touchscreen pressure calibration value will be shown in the Touchscreen Pressure data field.

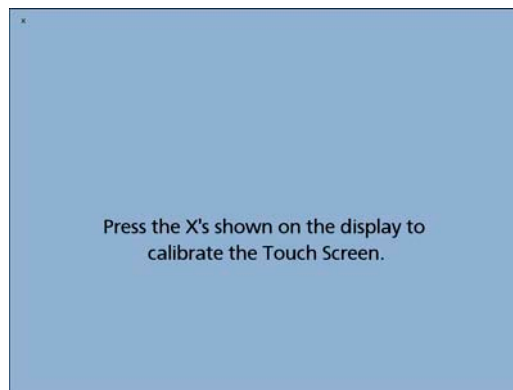

## Touch screen cursor

A green cross mark cursor can be displayed on the touchscreen briefly to indicate the touch-point as visual feedback for the user.

Touch the Show Touch Screen Cursor choice field to toggle the choice between Yes and No.

Show Touch Screen Cursor: No      Show Touch Screen Cursor: Yes



## Touch screen repeat delay

The feature list can be scrolled by touching and continuously pressing the scroll arrows at the bottom of the list. The scroll rate is inversely proportional to the touch screen repeat delay. Small delays result in rapid scrolling, large delays result in slow scrolling. Adjust the scroll rate by touching the Touch Screen Repeat Delay data field and entering the desired delay in milliseconds.

Touch Screen Repeat Delay: 150      Touch Screen Repeat Delay: 750



## Touch zone size

The size of the touch zone can be changed to accommodate different users. When the touch zone size value is zero, the touch zone extends only to the limits of the choice or data field. As the touch zone value is increased, the touch zone is increased beyond the perimeter of the field on all sides. The touch zone value is expressed in screen pixels.

Show Touch Screen Cursor:

*Default touch zone size*

Show Touch Screen Cursor:

*Enlarged touch zone size*

To change the size of the touch zone, touch the Touch Zone Size field and enter the new value using the number keys.

Touch Zone:  Touch Zone:



### CAUTION

**Increasing the touch zone size significantly might cause interference between adjacent fields.**

## Screen contrast and brightness

The LCD display contrast and brightness can be adjusted to accommodate different ambient lighting conditions.

To adjust contrast or brightness, touch the Screen Contrast Level or Screen Brightness Level data field and enter the desired value (min = 0, max = 100).

Screen Contrast Level:

Screen Brightness Level:

Screen Contrast Level:

Screen Brightness Level:



# Chapter 11:

## Problem Solving

The QC-300 is based on years of experience manufacturing the Metronics QC-100, QC-200 and QC-5000 products. Years of continuous improvement have resulted in extremely reliable operation and few, if any problems. Problems experienced with the operation of the QC-300 are likely to be the result of printer or cable incompatibilities, instrument configuration or setup errors, encoder incompatibilities or malfunctions or video configuration and calibration issues.

The steps recommended for initial troubleshooting are shown below. These are typically the same initial steps that would be taken by a distributor or factory product support technician.

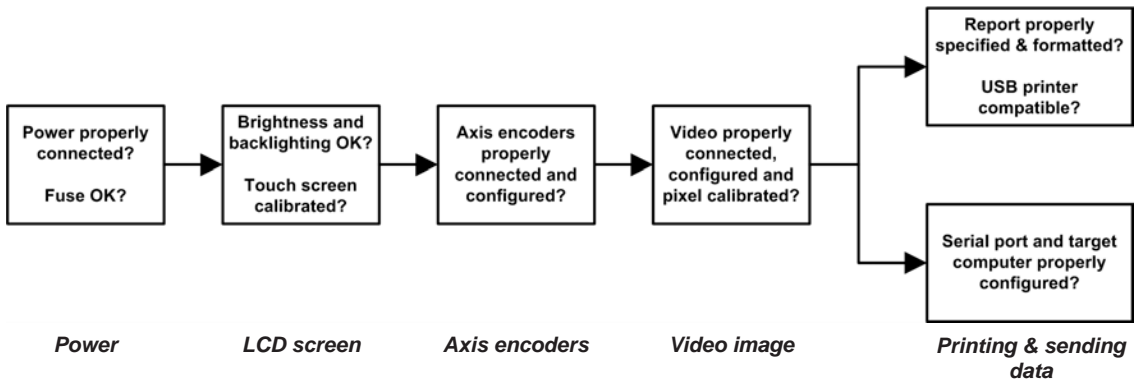

Since most problems experienced in the field will have simple causes, and equally simple solutions, substantial time and expense can be saved by performing some straightforward troubleshooting of configuration settings and hardware connections prior to calling the distributor or factory for assistance.

As you're troubleshooting, list the steps that you use to identify and solve your problem. Should problems persist in spite of your efforts, gather the product information listed at the end of this chapter, and your list of troubleshooting steps, and then contact your distributor for assistance.



### NOTE

Confirm that the essential setup steps described in **Chapter 10: Setup** have been performed before troubleshooting or requesting assistance.

## Symptoms, probable causes and solutions

Some common symptoms of problems are listed in the following pages with probable causes and possible solutions.

### No image is visible on the LCD screen

**Probable cause 1:** *Power is not applied to the QC-300*

**Possible solutions:**

- 1 Activate the main power source.
- 2 Connect the power cord or turn the power ON.
- 3 Replace the fuse.

**Probable cause 2:** *LCD ON/OFF toggle switch is in the OFF mode*

**Possible solution:**

- 1 *Press the LCD ON/OFF button to toggle the LCD ON.*

**Probable cause 3:** *LCD contrast or backlighting is out of adjustment*

**Possible solution:**

- 1 *Perform the following procedure to reset the LCD contrast and backlighting parameters to factory defaults.:*
  - *Turn the power OFF*
  - *Press and hold the 0 numeric keypad key and turn the power back ON while continuing to hold the numeric 0 key down until the screen flashes*
  - *Release the 0 numeric keypad key*

### Values displayed on the LCD screen are incorrect

**Probable cause 1:** *The axis encoder is not connected or is malfunctioning*

**Possible solutions:**

- 1 *Connect the axis encoder cable firmly to the QC-300.*
- 2 *Replace the axis encoder.*

**Probable cause 2:** *The Encoders setup screen specifies the wrong axis encoder resolution*

**Possible solution:**

- 1 *Specify the correct resolution in the Encoders setup screen.*

**Probable cause 3: The wrong axis encoder count polarity is specified in the Encoders setup screen**

**Possible solution:**

- 1 Specify the correct count polarity in the Encoders setup screen.

**Probable cause 4: The wrong encoder is connected to the axis**

**Possible solutions:**

- 1 Connect the axis encoder specified in the Encoders setup screen.
- 2 Confirm that the each encoder is connected to the correct axis input.

**Probable cause 5: The wrong in/mm unit of measure is specified**

**Possible solution:**

- 1 Specify the correct units of measure in the Encoders setup screen.

**Probable cause 6: The wrong encoder reference mark is specified**

**Possible solution:**

- 1 Correct the reference mark type in the Encoders setup screen.

**Probable cause 7: Error correction is required to compensate encoder inaccuracies:**

**Possible solutions:**

- 1 Perform LEC, SLEC or optional NLEC error correction in the corresponding error screen.
- 2 Error correction was performed but not enabled. Enable error correction in the LEC, SLEC or optional NLEC setup screen.

**Probable cause 8: Video resolution is not calibrated:**

**Possible solutions:**

- 1 Calibrate the video pixel resolution in the VED setup screen.

**Probable cause 9: The wrong video camera is specified:**

**Possible solutions:**

- 1 Specify the correct camera in the VED setup screen.

## Reports are not printed or are incomplete

**Probable cause 1:** *The channel input device is not connected or is malfunctioning*

**Possible solution:**

- 1 *The printer is not supported by the QC-300. Certain HP USB 1.1 printers are supported. Printers must be approved by Metronics.*

**Probable cause 2:** *The USB cable is not firmly connected or is damaged*

**Possible solution:**

- 1 *Connect or replace the printer cable.*

**Probable cause 3:** *The printed report setup is incorrect*

**Possible solution:**

- 1 *Correct the report setup in the Print setup screen.*

## Reports are printed incorrectly

**Probable cause 1:** *The printed report setup is incorrect*

**Possible solution:**

- 1 *Correct the report setup in the Print setup screen.*

**Probable cause 2:** *The wrong control characters are specified*

**Possible solution:**

- 1 *Correct the control character configurations in the Print setup screen.*

## Data cannot be transmitted to a computer

**Probable cause 1:** *The wrong serial cable (or no cable) is connected between the computer and the QC-300*

**Possible solution:**

- 1 Connect the computer to the QC-300 using an RS-232 serial cable that does not include crossed transmit and receive wires. The correct cable can be ordered from Metronics by specifying part number 11B12176.

**Probable cause 2:** *The wrong RS-232 port settings are specified*

**Possible solution:**

- 1 Correct the RS-232 port settings to match the computer's serial port settings in the Port setup screen.

**Probable cause 3:** *The wrong control characters are specified*

**Possible solution:**

- 1 Correct the control characters to reflect the requirements of the receiving software in the Print setup screen

## Getting help from your distributor

Performing the simple troubleshooting listed on the previous pages solves most problems experienced with the QC-300. If a problem persists after performing this troubleshooting, follow the steps listed below and contact your distributor for assistance.

- 1 Be prepared to discuss your troubleshooting steps.
- 2 Gather the following QC-300 information:
  - Model number
  - Serial number
  - Approximate purchase date
  - Software version number and hardware information from the Hardware setup screen.

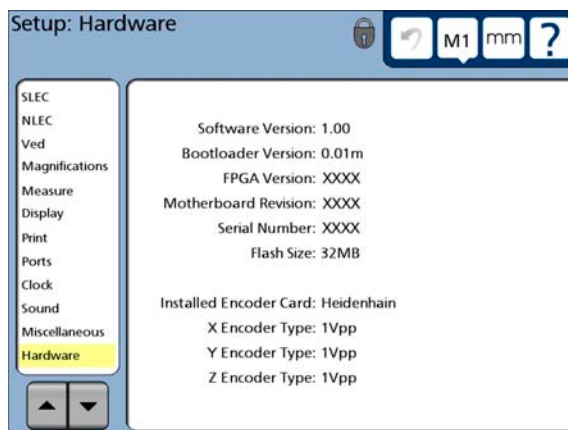



# Chapter 12:

## Reference Material

This chapter contains technical information regarding:

- QC-300 product specifications
- Footswitch wiring
- Tolerances
- RS-232 connector wiring
- Lighting/Zoom connector wiring

### Product specifications

#### ***Electrical***

Input Voltage Range: 85 VAC to 264 VAC. 1.0 Amp maximum (Auto switching)  
 Fuse: 1.6 Amp 250 VAC Slow Blow 5 x 20 mm  
 Input Frequency: 43 Hz to 63 Hz

#### ***Environmental***

Temperature: 0 °C to 45 °C (32 °F TO 113 °F) non-condensing  
 Humidity: 90% rh maximum  
 Altitude: 2000 meters (6,562 ft) maximum  
 Installation: Category: II

#### ***Dimensions***

Enclosure (W x H x D): 29.2 cm x 19.1 cm x 7.0 cm (11.5" x 7.5" x 2.75")  
 Base (W x H x D): 25.4 cm x 5.1 cm x 19.8 cm (10" x 2" x 7.8")  
 Enclosure weight: 1.6 kg (3.5 lbs.)  
 Base weight: 3.2 kg (7 lbs.)

#### ***LCD***

Size/color: 21.3 cm (8.4 inch) TFT color touch screen  
 Display digit size: 1.27 cm (0.5 inch)  
 Resolution: 0.0001 mm (0.000004 inch)

#### ***ENC tests***

EN61000-4-3, EN61000-4-4, EN61000-4-5, EN61000-4-6, EN61000-4-11

## Footswitch wiring

The optional foot switch is connected to the RJ-45 connector on the left side of the QC-300.

The wiring of the footswitch is sometimes duplicated by other external switching devices to facilitate remote operation in conjunction with other devices in a larger semi-automated system.

*Footswitch and keypad connector*



### CAUTION

**Never apply power to the foot-switch wires. Applying power to the connector wires or wiring the switch connector in any way other than shown by this diagram can cause serious damage the QC-300 and void the product warranty.**

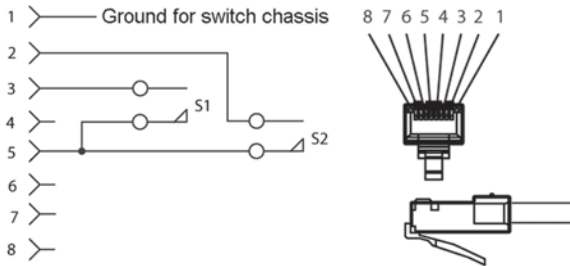

## RS-232 connector wiring

The RS-232 wiring is shown by the table below.

Pin No.	Description	Direction
2	Data in	Input
3	Data out	Output
7	Signal ground	Reference
8	Power on	Output (always high)

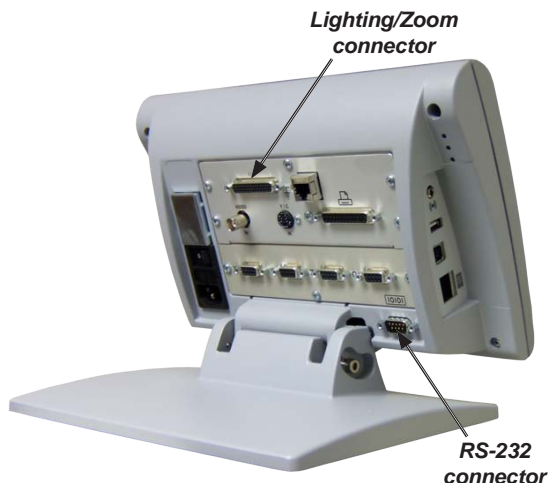

## Lighting/Zoom connector wiring

The Lighting/Zoom connector wiring is shown by the table below.

32	Lamp enable ground #1	
16	Lamp output #1	Vout software selectable range 0-5
31	Lamp enable #1	Output TTL
1	Lamp output #2	Vout software selectable range 0-5v
17	Lamp enable #2	Output TTL
2	Lamp output #3	Vout software selectable range 0-5v
18	Lamp enable #3	Output TTL
3	Lamp output #4	Vout software selectable range 0-5v
19	Lamp enable #4	Output TTL
33	Lamp output ground #1	Ground
35	Lamp enable ground #2	Ground
4	Lamp output #5	Vout software selectable range 0-5v
34	Lamp enable #5	Output TTL
20	Lamp output #6	Vout software selectable range 0-5v
5	Lamp enable #6	Output TTL
21		
36		
6		
22		
37	Lamp output ground #2	Ground
38	Zoom ground	Ground
7	Zoom step	Output TTL
8	Zoom limit switch #1	Input TTL 0-5V (only)
23	Zoom direction	Output TTL
24	Zoom limit switch #2	Input TTL 0-5V (only)
9	Encoder (a)	Output TTL
39	Encoder (b)	Input TTL 0-5V (only)
25	+5V	Output TTL
10		
40		
41	TTL output ground	Ground
42	TTL output #1	Output TTL
43	TTL output #2	Output TTL
26		
11		
27		
12		
28		
13		

## Tolerances

The following information is supplemental to the tolerance discussions provided earlier in [Chapter 7: Tolerancing](#).

### ***Concentricity tolerance***

The mathematical definition of concentricity is explained in detail in the ASME Y14.5M-1994 standard and involves “the midpoints of opposing elements” in the determination of actual concentricity. This is not practical in a discrete point measuring system, so the QC-300 uses the center of the feature (determined by the best fit) to estimate the concentricity.

### ***Reference Features***

When a reference feature is called for in a tolerance definition, the reference feature will nearly always refer to a datum feature such as a skew line or datum circle. The field is required except for the MMC / LMC tolerance case.

# Chapter 13: Options

Available options for the QC-300 are listed and shown here with Metronics part numbers:

- Foot switch for remote operation
- Keypad for remote operation
- RS-232 cable without crossed cable wiring for communication with computers
- Arm-mounting bracket and bracket adapter for mounting the QC-300 on vertical surfaces (must be ordered together)
- Taltech WinWedge© for inputing serial data directly from the QC-300 into any PC application

Contact the Metronics sales group by phone at 603.622.0212 or by e-mail at [sales@metronics.com](mailto:sales@metronics.com) to order QC-300 options.

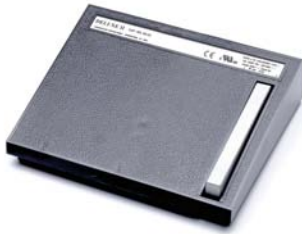

**Foot switch w/8 ft cable**  
11B12816



**Remote keypad**  
w/15 ft cable 11D12769-1  
w/25 ft cable 11D12769-2



**Serial cable**  
11B12176



**QC arm-mounting bracket**  
38-22-60-101



**QC arm-mounting bracket adapter**  
11D12764



**Taltech WinWedge software**  
54-775-005

# INDEX

## Symbols

- 2-Wire 6
- 2-Wire to 3-wire adapters 6
- 3-Wire 6
- 3-Wire adapters 6

## A

- About screen 181, 182
- Absolute reference marks 185
- Adding video magnifications 196
- Adjusting light control 40
- Adjustment slider 42
- Altitude 225
- Angle 56
- Angle constructed from an angle 133
- Angle constructed from two lines 134
- Angle constructions 133
- Angles 75, 84
- Angle tolerances 150
- Angular units of measure 207
- Annotation type 203
- Anomalies 61
- Appending new program steps 165
- Arc constructed from an arc 131
- Arc constructed from an arc and a distance 131
- Arc constructed from multiple features 132
- Arc constructions 131
- Archiving and retrieving programs 168
- Arcs 56, 75, 79, 145, 146
- Arm-mounting bracket and bracket adapter 229
- ASCII code table 174
- ASME Y14.5M-1994 standard 139
- Assistance. 219
- Auto-enter function 49, 51
- Auto-point entry 48
- Automatic probing (crosshairs) 53
- Automatic probing (single edge) 55
- Avoid erroneous data 61
- Axes on display printouts 211

- Axis-zeroing on the video DRO 194
- Axis choices 184
- Axis encoders 7
- Axis error messages 186

## B

- Back light 40
- Back lighting 220
- Backup battery 176
- Backward/forward annotation 76, 203
- Baud rate 212
- Best fit algorithm 80, 139
- Bidirectional tolerance 144
- Bolt holes 3
- Bonus 147
- Bores 147
- Bosses 147
- Bracket 229
- Bracket adapter 229
- Brightness 43, 217
- Buffer page 211

## C

- Calibrating squareness of the measuring system 187
- Calibrating the touchscreen 216
- Calibrating video magnification pixel size 197
- Calibrations 200
- Camera lighting and zoom 10
- Camera optics 40
- Camera skew calibrations 195
- Channel input devices 7
- Circle constructed from a circle 128
- Circle constructed from a circle and a distance 129
- Circle constructed from multiple features 130
- Circle constructed from two circles 129
- Circle constructions 128
- Circles 56, 75, 80
- Circles and arcs 145, 146
- Circles constructed from two lines 128
- Communication 169
- Communication retries 211
- Computer 9, 169, 170
- Concentricity tolerance 149, 228

- Configuration 175
  - Connecting a computer 169
  - Connecting a printer 171
  - Connecting axis encoders 7
  - Constructing a datum zero point 70
  - Constructing features 85
  - Contrast 43, 220
  - Contrast and brightness 217
  - Contrast threshold 193
  - Control characters 222, 223
  - Count direction 186
  - Creating a circle 136
  - Creating a line 136
  - Creating an arc 137
  - Creating a point 135
  - Creating a rectangle 138
  - Creating a slot 137
  - Creating features 135
  - Creating programs 153
  - Crosshair 46
  - Crosshair probe data collection parameters 49
  - Crosshair probes 1, 52
  - Crosshair timeout delay 49
  - Crosshair timeout delay 48
  - Cursor 216
- D**
- Data transmitted to a computer 223
  - Data destination 210
  - Data errors 62
  - Data points required 203
  - Data points required by the system to complete a feature measurement 203
  - Data type 210
  - Date 213
  - Date formats 207
  - Datums 25, 204
  - Datum zero point 69, 70
  - Deleting programs 168
  - Deleting setup data 178
  - Deleting video magnifications 196
  - Demonstration 25
  - Dimension formula 221
  - Dimensions 225
  - Direction 186
  - Display digit size 225
  - Displayed language 181
  - Display mode switching 208
  - Display printouts 211
  - Display resolution 206
  - Display screen 206
  - Display the tolerance screen 34, 141
  - Distance constructed from a distance 111
  - Distance constructed from a line 116
  - Distance constructed from a line and a rectangle 116
  - Distance constructed from a line and a slot 120
  - Distance constructed from a point and a slot 114
  - Distance constructed from two distances 120
  - Distance constructed from two slots 124
  - Distance constructions 111
  - Distances 56, 75,, 83, 205
  - Distances constructed between two rectangles 126
  - Distances constructed from a line and a circle 118
  - Distances constructed from a line and an arc 119
  - Distances constructed from an arc and a circle 123
  - Distances constructed from a point and a circle 113
  - Distances constructed from a point and a line 112
  - Distances constructed from a point and an arc 115
  - Distances constructed from a point and a rectangle 112
  - Distances constructed from a rectangle and a circle 122
  - Distances constructed from a rectangle and an arc 125
  - Distances constructed from a slot and a circle 122
  - Distances constructed from a slot and an arc 124
  - Distances constructed from a slot and a rectangle 125
  - Distances constructed from two arcs 127
  - Distances constructed from two circles 121
  - Distances constructed from two lines 117
  - Distances constructed from two points 111
  - Distributor 223
  - DRO alpha blending 209
  - DRO threshold 215
  - Dual view mode 208

**E**

Ear phones 2  
Edge 46  
Edge detection 39  
Edge probe data collection parameters 50  
Edge timeout delay 50  
Editing existing steps 160  
Editing light intensities 163  
Editing magnifications 160  
Editing programs 160  
Editing user prompt messages 164  
Electrical 225  
Electrical wiring and connections 6  
Encoder count direction 186  
Encoder resolution 184  
Encoders 7  
Encoder type 184  
ENC tests 225  
Entering and deleting setup data 178  
Environmental 225  
EOC delay 212  
EOL delay 212  
Erroneous data 61  
Error messages 186  
Errors 62  
Essential setup requirements 180  
Export results 25

**F**

Feature anomalies 61  
Feature measurement 203  
Features 31  
Feet 3  
Foot switch 229  
Foot switch 3, 8  
Foot switch for remote operation 229  
Footswitch wiring 226  
Forward annotation 76, 203  
Front panel keys 1  
Fuse 225

**G**

Getting help from your distributor 223

**H**

Hard stop 185  
Hardware setup screen 223  
Help 223  
Hiding setup parameters from unauthorized personnel 182  
Humidity 225

**I**

Image contrast and brightness 43  
Image controls 195  
Initial troubleshooting 219  
Input frequency 225  
Input voltage range 225

**K**

Keypad 229  
Keypad for remote operation 229  
Keyways 61

**L**

Labeling axes on display printouts 211  
Language 181  
Language screen 181  
LCD 225  
LCD contrast or backlighting 220  
LCD screen 220  
LEC (linear error correction) 188  
LEC or SLEC, which is right for my application? 188  
Leveling the part (optional) 67  
Light control 40  
Lighting 10  
Lighting/zoom connector wiring 227  
Lightning 7  
Light settling time 193  
Light source 40  
Limit 35, 142  
Limiting access to program functions 182



- Line 56
- Line constructed from a distance 95
- Line constructed from a line 94
- Line constructed from a line and a distance 100
- Line constructed from a line and an angle 102
- Line constructed from a point and a rectangle 97
- Line constructed from a point and a slot 97
- Line constructed from a rectangle 110
- Line constructed from a slot 105
- Line constructed from multiple features 110
- Line constructed from two arcs 109
- Line constructed from two points 94
- Line constructed from two slots 105
- Line constructions 94
- Lines 75, 78, 144, 146
- Lines constructed between two rectangles 108
- Lines constructed from a circle and an arc 104
- Lines constructed from a circle and a rectangle 106
- Lines constructed from a circle and a slot 105
- Lines constructed from a line and a circle 100
- Lines constructed from a line and an arc 101
- Lines constructed from a line and a rectangle 102
- Lines constructed from a line and a slot 101
- Lines constructed from a point and a circle 96
- Lines constructed from a point and a line 95
- Lines constructed from a point and an arc 98
- Lines constructed from a rectangle and an arc 107
- Lines constructed from a slot and an arc 106
- Lines constructed from a slot and a rectangle 107
- Lines constructed from two circles 103
- Lines constructed from two lines 99
- LMC tolerance 147
- LMC tolerances 147
- Loading settings 183
- Locking features to their original datums 204
- Locking the contrast threshold 194
- Lock programs 177, 182

## M

- Machine zero position 205
- Machine zero reference 186
- Magnification 40
- Magnification calibrations 194
- Magnification pixel size 197

- Magnifications screen 196
- Manual comparator 25
- Manual probing (crosshairs) 52
- Manual probing (single edge) 54
- Manual reference mark 185
- Measure magic 73
- Measurement activities 66
- Measurement axis choices 184
- Measurement process 66
- Measurement reference 67
- Measurements 1
- Measure part features 25
- Measure screen 203
- Measuring 65
- Measuring features 31, 73
- Menu 176
- Message 155
- Messages 186
- Metronics QC Quickie slide 25
- Minimum points required for a feature measurement 203
- Minimum probed points 193
- Misaligned parts 1
- Misalignment 68
- Misalignment errors 68
- Miscellaneous screen 215
- MMC and LMC tolerances 147
- MMC circles and arcs 147
- Motion distance 49
- Mounting stand 6
- Multiple edge 46
- Multiple edge probe 56

## N

- New program steps 165
- No image is visible on the lcd screen 220
- Noisy environments 2
- Nominal 35, 142
- NTSC 2, 10

## O

- Offset crosshair 46
- Operating parameters of the QC-300 175
- Optical edge detection 25

- Options for the qc-300 229
- Original datums 204
- Overview 1
- P**
- Pal 10
- Pal format 2
- Parallel communication retries 211
- Parallelism tolerances 150
- Parallel port configuration 222
- Parallel printer 171
- Parameter choices 178
- Parfocal calibration 200
- Parity 212
- Part condition 40
- Part level 1
- Part misalignment 68
- Pass/fail results 35, 142
- Password 177, 182
- Perpendicularity tolerance 150
- Pixel size 197
- Point constructed from a circle 89
- Point constructed from a distance and a point 89
- Point constructed from an angle 92
- Point constructed from an arc 93
- Point constructed from a point 85
- Point constructed from a point and a line 85
- Point constructed from a rectangle 92
- Point constructed from multiple features 93
- Point constructed from two lines 88
- Point constructions 85
- Point entry 48
- Points 56, 75, 77, 144, 193
- Points and lines 146
- Points constructed from a circle and a line 90
- Points constructed from a distance 88
- Points constructed from a line 87
- Points constructed from an arc and a line 86
- Points probed automatically 56
- Points probed for a line, circle and arc 50
- Points required for a feature measurement 203
- Points to be collected 48
- Position tolerances 146
- Power 6
- Power cord and plug 6
- Power line transients 7
- Power surge suppressor 7
- Print a report of the QC-300 setup parameters 173
- Print button 210
- Printer 9, 171
- Printer format strings 171
- Print feature measurement data 172
- Printing a report 172
- Printing QC-300 system settings 173
- Printing reports 172
- Printing units of measure on reports 211
- Printouts 211
- Print screen 210
- Probe a circle using the multiple edge probe 58
- Probe a line using the multiple edge probe 57
- Probe an arc using the multiple edge probe 60
- Probe color 47
- Probe data collection parameters 48, 49, 50
- Probed points 193
- Probes 39
- Probe seeding 56
- Probe type 46
- Probing (crosshairs) 52
- Probing (single edge) 54
- Probing a datum zero point 69
- Probing and measuring features 73
- Probing angles 84
- Probing arcs 79
- Probing a single specific feature type 74
- Probing circles 80
- Probing distances 83
- Probing lines 78
- Probing multiple specific feature type 74
- Probing points 77
- Probing process 75
- Probing rectangles 82
- Probing slots 81
- Probing specific feature types 74, 77
- Probing with measure magic 73
- Problem solving 219
- Product specifications 225
- Program editing 160
- Program functions 182
- Programming 153
- Programming tools 154

Program recording 154  
Programs 2  
Programs are deleted 168  
Programs are run 167  
Program title 155  
Protrusions 61

## Q

QC-300 information 223  
QC Quickie slide 25

## R

Radix for numeric displays 207  
Recovering from data errors 62  
Rectangles 56, 75, 82, 145  
Reference 67  
Reference features 228  
Reference marks 185  
Reference material 225  
Registration form 11  
Repackage the QC-300 11  
Repackaging for shipment 11  
Repackaging instructions 5  
Repeat delay 216  
Report 172  
Report formats 171  
Reports 36, 211  
Reports are not printed or are incomplete 222  
Reports are printed incorrectly 222  
Resolution 184, 206  
Retaining feature data through a power cycle 204  
Retrieving programs 168  
Return to DRO threshold 215  
Ring lights 40  
RJ-45 connector 8  
Roundness tolerance 149  
RS-232 2  
RS-232 cable 229  
RS-232 cable without crossed cable wiring 229  
RS-232 connector wiring 227  
RS-2322 port settings 223  
RS-232 serial port 9, 169, 170  
RS-232 connector pin designations 174  
Running programs 37, 167

Runout tolerance 149

## S

S-video 10  
S-video signals 2  
Safety 6  
Scan lines 46  
Screen contrast 193  
Screen contrast and brightness 217  
Screen saver delay 208  
Seeding multiedge probe 56  
Seeding to avoid erroneous data 61  
Select a specific tolerance 35, 142  
Selecting an axis to configure 184  
Selecting a probe 46  
Selecting setup parameter choices 178  
Selecting video magnification 40  
Sending data to a computer 170  
Serial cable 223  
Serial port 170  
Settling time 193  
Setup 175  
Setup menu 176  
Setup parameter choices 178  
Setup privileges 182  
Setup requirements 180  
Setup screen descriptions 180  
Setup screens and functions 176  
Shipment 11  
Signed distances 205  
Single edge 46  
Single edge probe 54  
Single view mode 208  
Skew 1, 25  
Skew alignment 68, 69  
Skewing the part 68  
SLEC (segmented linear error correction) 186, 190  
SLEC screen 188  
Slider 42  
Slot 56, 75, 81  
Slots and rectangles 145  
Sound screen 214  
Speaker 2  
Speaker jack outputs 2  
Specifications 225

Squareness screen 187  
Stage motion 48  
Stage movement 49  
Startup zero 205  
Stop bits 212  
Stopping the program recording 37  
Stop recording 37, 159  
Storing a parameter 179  
Straightness tolerance 149  
Supervisor password 177, 182  
Supervisor screen 182  
Surge suppressor 7  
System and part condition 40

## T

Taltech winwedge© 229  
Temperature 225  
Tests 225  
Text entry screen 155  
Text message 155  
Tilt front panel 3  
Time 213  
Time formats 207  
Timeout delay 48  
Tolerance 25, 35, 139, 141, 142  
Tolerance bonus 147  
Tolerance report 25  
Tolerance screen 34, 141  
Tolerance type 34, 141  
Top light 40  
Touchscreen calibration rows and columns 215  
Touch screen cursor 216  
Touch screen repeat delay 216  
Touch zone size 217  
Transients 7  
Troubleshooting 219  
Troubleshooting list 223  
True position tolerance 146

## U

Unauthorized personnel 182  
Units of linear measure 207, 221  
Units of measure 211  
Unpacking 5

Unpacking the QC-300 5  
USB 2  
USB port 172  
USB printers 171  
User message 155  
Using video probes 40

## V

Values displayed on the LCD screen are incorrect 220  
Ved screen 193  
Video camera inputs 2  
Video DRO 209  
Video DRO alpha blending 209  
Video edge detection 1, 39  
Video image contrast and brightness 43  
Video input 10  
Video magnification calibrations 194  
Video magnification pixel size 197  
Video magnifications 40, 196  
Video parcentric and parfocal calibrations 200  
Video probes 40, 46

## W

Warranty registration 11  
Weight 225  
Width tolerance 151  
Winwedge© 229  
Wiring 226  
Wiring and connections 6  
Word length 212

## Z

Zoom 10

