

# PRODUCT QUICK SHEET

## Remote Detector

1Vpp and 11μApp incremental signals have been ubiquitous in measuring devices since the 1980's. The most common are glass scales used in CNC feedback systems for linear and angular measurement. Maintenance of these systems is critical to sustaining machine up-time and peak performance. Remote Detectors are permanently installed, in-line with the feedback signals, to continuously monitor the health of your feedback devices and predict failures before they occur.

- Predict machine crippling failures
- 24/7/365 monitoring of scale signals
- User customizable warning and fault limits
- Real time email and text alerts<sup>1, 2</sup>
- Avoid manufacturing process interruptions
- Identify noise caused by contaminated power<sup>1</sup>
- Capture intermittent signal and power faults
- Easy Plug-n-Play installation
- Give service technicians remote access to live diagnostic data<sup>1</sup>
- Embedded MTConnect Adapter

1. Available through the MERIDIAN Cloud Service  
 2. MTConnect alerting can be achieved using a dashboard tool such as Grafana

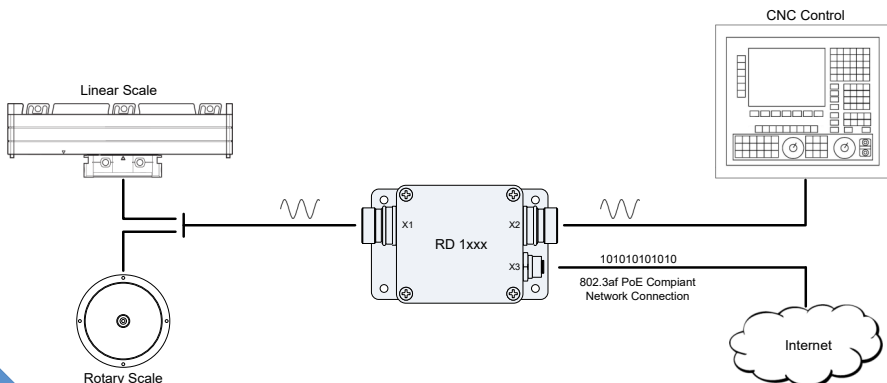

The simplest, and most common, installation is shown to the left. The Remote Detector is installed in-line with the feedback signals and powered by a PoE enabled ethernet cable with internet access. The Remote Detector will automatically connect to the MERIDIAN Cloud Service and begin reporting. Simply login to your free MERIDIAN Cloud account and register your device. It's that easy!

All Remote Detectors include free basic access to the MERIDIAN Cloud Service. Through the MERIDIAN Cloud Service, users can easily view their scale’s performance characteristics, customize the Remote Detector’s alert settings and much more. Advanced service level access allows for viewing live samples of the scale signals directly from the technician’s PC for fast, accurate diagnostics and troubleshooting regardless of their location.

The Remote Detector series of devices are designed to be permanently installed in-line between the incremental scale and the control, allowing for real time analysis of scale conditions. With a cloud based installation, performance data and event information are transmitted using encrypted TCP/IP protocol over standard Ethernet to the MERIDIAN Cloud Service. It is often said that the use of a Remote Detector is synonymous with having a trained technician watching your feedback system 24/7/365.

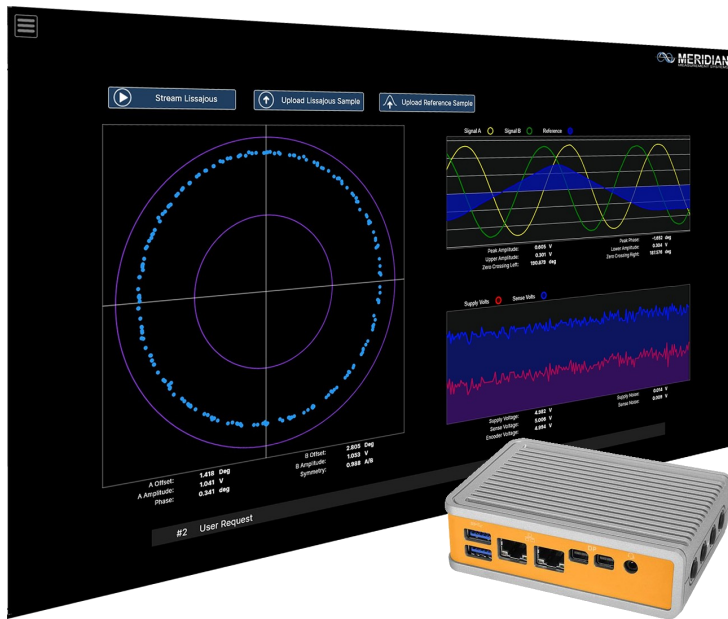

For air-gapped or offline installations, Remote Detectors can be paired with a MERIDIAN Gateway device. The GW 1xxx is a Data Acquisition Server & Gateway which collects data from a network of Remote Detectors, and stores the results in an internal, non-volatile database. The data can be displayed locally in real-time on a connected monitor, sent to the MERIDIAN Cloud, or collected later via MTConnect®.

With the built-in oscilloscope tool, there is no need to shut down production to plug in external diagnostic equipment. Technicians can easily view live scale conditions in the connected monitor to rapidly diagnose problems and keep your machine in production.

**MTConnect**® To accommodate industry 4.0 installations, all Remote Detectors include a built-in MTConnect Adapter for easy integration into any MTConnect infrastructure. Each Remote Detector can be customized to adapt to fit any Devices.xml Schema. The built-in MTConnect Adapter outputs standard SHDR Pipe Delimited data which can be read by any standard MTConnect Agent.

**FOR MORE INFORMATION, SALES, AND SERVICE CONTACT:**

A TECH AUTHORITY, INC. - SALES@ATECHAUTHORITY.COM - (909) 614-4522