



HEIDENHAIN



Rotary Encoders

SALES & SERVICE:

A Tech Authority, Inc.
13745 Stockton Ave.
Chino CA 91710
909-614-4522
sales@atechauthority.com

12/2021

Rotary encoders from HEIDENHAIN serve as feedback devices for rotary motion and angular speed. When used in conjunction with mechanical measuring standards such as lead screws, they can also measure linear motion. Possible applications include electric motors, machine tools, printing machines, woodworking machines, textile machines, robots, and handling devices, as well as a wide variety of measuring, testing, and inspection devices. The high quality of their sinusoidal incremental signals permits high interpolation factors for digital speed control.



Rotary encoders for separate shaft coupling



Electronic handwheel



Rotary encoders with mounted stator coupling

Information about

- Encoders for servo drives
- Sealed angle encoders
- Modular angle encoders with optical scanning
- Modular angle encoders with magnetic scanning
- Linear encoders for numerically controlled machine tools
- Exposed linear encoders
- Signal converters
- HEIDENHAIN controls, and
- Cables and connecting elements is available upon request as well as on the Internet at www.heidenhain.com.

Further information:

For detailed descriptions of all available interfaces, as well as general electrical information, please refer to the *Interfaces of HEIDENHAIN Encoders* brochure.

This brochure supersedes all previous editions, which thereby become invalid. The basis for ordering from HEIDENHAIN is always the current product documentation at the time the order is placed.







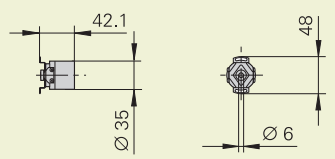

Standards (ISO, EN, etc.) apply only where explicitly stated in this brochure.

Contents

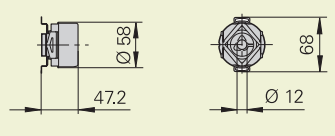
Introduction				
	Selection guide		4	
	Measuring principles, accuracy		14	
	Mechanical design types and mounting	Rotary encoders with stator coupling	16	
		Rotary encoders for separate shaft coupling	19	
		Shaft couplings	24	
	General mechanical information		27	
	Safety-related position measuring systems		30	
Specifications	Absolute rotary encoders	Incremental rotary encoders		
<i>Mounted stator coupling</i>	ECN 1000/EQN 1000 series	ERN 1000 series	32	
	ECN 400/EQN 400 series	ERN 400 series	36	
	ECN 400F/EQN 400F series	–	44	
	ECN 400S/EQN 400S series	–		
	ECN 400/EQN 400 series with universal stator coupling	ERN 400 series with universal stator coupling	46	
	ECN 100 series	ERN 100 series	50	
	<i>Separate shaft coupling; synchro flange</i>	ROC/ROQ 1000 series	ROD 1000 series	52
		ROC/ROQ 400 series	ROD 400 series	56
		ROC 400F/ROQ 400F series	–	64
		ROC 400S/ROQ 400S series	–	
ROC 425 series with high accuracy		–	66	
<i>Separate shaft coupling; clamping flange</i>	ROC/ROQ 400 series	ROD 400 series	68	
	ROC 400F/ROQ 400F series	–	72	
	ROC 400S/ROQ 400S series	–		
		ROD 600 series	74	
<i>Separate shaft coupling; mounting via flange/base</i>	–	ROD 1930 Sturdy design	76	
<i>Handwheels</i>	–	HR 1120	78	
Electrical connection				
	Interfaces	Incremental signals	80	
		Position values	85	
	Cables and connecting elements		90	
	Signal converters		94	
	Testing and inspection devices, and diagnostics		96	

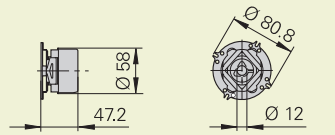
Selection guide

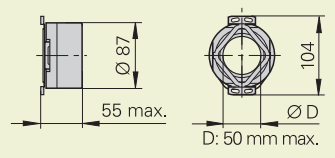
Rotary encoders for standard applications

Rotary encoders	Absolute Singletum			Multitum 4096 revolutions			Incremental			
	Interface	EnDat	Fanuc Siemens	SSI	EnDat	Fanuc Siemens	SSI	TTL	HTL	~ 1 V _{PP}
With mounted stator coupling										
ECN/EQN/ERN 1000 series 	ECN 1023 Positions/rev: 23 bits EnDat 2.2/22 ECN 1013 Positions/rev: 13 bits EnDat 2.2/01	ECN 1023 S Positions/rev: 23 bits DRIVE-CLiQ	–	EQN 1035 Positions/rev: 23 bits EnDat 2.2/22 EQN 1025 Positions/rev: 13 bits EnDat 2.2/01	EQN 1035 S Positions/rev: 23 bits	–	ERN 1020 100 to 3600 lines ERN 1070 1000/2500/3600 lines ¹⁾	ERN 1030 100 to 3600 lines	ERN 1080 100 to 3600 lines	 32
ECN/EQN/ERN 400 series 	ECN 425 Positions/rev: 25 bits EnDat 2.2/22 Available with functional safety ECN 413 Positions/rev: 13 bits EnDat 2.2/01	ECN 425 F Positions/rev: 25 bits Fanuc αi ECN 424 S Positions/rev: 24 bits DRIVE-CLiQ Available with functional safety	ECN 413 Positions/rev: 13 bits	EQN 437 Positions/rev: 25 bits EnDat 2.2/22 Available with functional safety EQN 425³⁾ Positions/rev: 13 bits EnDat 2.2/01	EQN 437 F Positions/rev: 25 bits Fanuc αi EQN 436 S Positions/rev: 24 bits DRIVE-CLiQ Available with functional safety	EQN 425³⁾ Positions/rev: 13 bits	ERN 420 250 to 5000 lines ERN 460²⁾ 250 to 5000 lines	ERN 430 250 to 5000 lines	ERN 480⁴⁾ 1000 to 5000 lines	 36
ECN/EQN/ERN 400 series with universal stator coupling 	ECN 425 Positions/rev: 25 bits EnDat 2.2/22 ECN 413 Positions/rev: 13 bits EnDat 2.2/01	–	ECN 413 Positions/rev: 13 bits	EQN 437 Positions/rev: 25 bits EnDat 2.2/22 EQN 425 Positions/rev: 13 bits EnDat 2.2/01	–	EQN 425 Positions/rev: 13 bits	ERN 420 250 to 5000 lines ERN 460²⁾ 250 to 5000 lines	ERN 430 250 to 5000 lines	ERN 480 1000 to 5000 lines	 46
ECN/ERN 100 series 	ECN 125 Positions/rev: 25 bits EnDat 2.2/22 ECN 113 Positions/rev: 13 bits EnDat 2.2/01	–	–	–	–	–	ERN 120 1000 to 5000 lines	ERN 130 1000 to 5000 lines	ERN 180 1000 to 5000 lines	 50

¹⁾ Up to 36000 signal periods via integrated 5/10-fold interpolation (higher interpolation upon request)







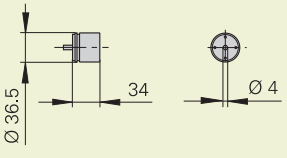

²⁾ Supply voltage: DC 10 V to 30 V

³⁾ Also available with TTL or HTL signal transmission

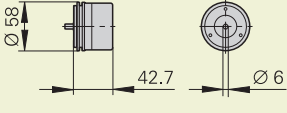
⁴⁾ Available with mechanical fault exclusion; for restrictions on specifications and for special mounting information, see the *Fault Exclusion* customer information document

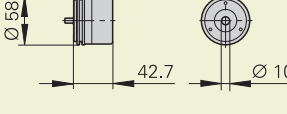
DRIVE-CLiQ is a registered trademark of Siemens AG.

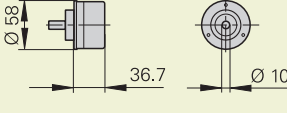

Rotary encoders for standard applications

Rotary encoders	Absolute Singletum			Multitum 4096 revolutions			Incremental			
	Interface	EnDat	Fanuc Siemens	SSI	EnDat	Fanuc Siemens	SSI	TTL	HTL	~ 1 V _{PP}
For separate shaft coupling, with synchro flange										
ROC/ROQ/ROD 1000 series 	ROC 1023 Positions/rev: 23 bits EnDat 2.2/22 ROC 1013 Positions/rev: 13 bits EnDat 2.2/01	ROC 1023 S Positions/rev: 23 bits DRIVE-CLiQ	–	ROQ 1035 Positions/rev: 23 bits EnDat 2.2/22 ROQ 1025 Positions/rev: 13 bits EnDat 2.2/01	ROQ 1035 S Positions/rev: 23 bits DRIVE-CLiQ	–	ROD 1020 100 to 3600 lines ROD 1070 1000/2500/3600 lines ²⁾	ROD 1030 100 to 3600 lines	ROD 1080 100 to 3600 lines	 52
ROC/ROQ/ROD 400 series with synchro flange 	ROC 425 Positions/rev: 25 bits EnDat 2.2/22 Available with functional safety ROC 413 Positions/rev: 13 bits EnDat 2.2/01	ROC 425 F Positions/rev: 25 bits Fanuc αi ROC 424 S Positions/rev: 24 bits DRIVE-CLiQ Available with functional safety	ROC 413 Positions/rev: 13 bits	ROQ 437 Positions/rev: 25 bits EnDat 2.2/22 Available with functional safety ROQ 425 Positions/rev: 13 bits EnDat 2.2/01	ROQ 437 F Positions/rev: 25 bits Fanuc αi ROQ 436 S Positions/rev: 24 bits DRIVE-CLiQ Available with functional safety	ROQ 425 Positions/rev: 13 bits	ROD 426 50 to 5000 lines ¹⁾ ROD 466 ³⁾ 50 to 5000 lines ²⁾	ROD 436 50 to 5000 lines	ROD 486 ⁵⁾ 1000 to 5000 lines	 56
ROC 425 for high accuracy 	ROC 425 Positions/rev: 25 bits EnDat 2.2/01	–	–	–	–	–	–	–	–	 66
For separate shaft coupling, with clamping flange										
ROC/ROQ/ROD 400 series with clamping flange 	ROC 425 Positions/rev: 25 bits EnDat 2.2/22 Available with functional safety ROC 413 Positions/rev: 13 bits EnDat 2.2/01	ROC 425 F Positions/rev: 25 bits Fanuc αi ROC 424 S Positions/rev: 24 bits DRIVE-CLiQ Available with functional safety	ROC 413 Positions/rev: 13 bits	ROQ 437 Positions/rev: 25 bits EnDat 2.2/22 Available with functional safety ROQ 425 ⁴⁾ Positions/rev: 13 bits EnDat 2.2/01	ROQ 437 F Positions/rev: 25 bits Fanuc αi ROQ 436 S Positions/rev: 24 bits DRIVE-CLiQ Available with functional safety	ROQ 425 Positions/rev: 13 bits	ROD 420 50 to 5000 lines	ROD 430 50 to 5000 lines	ROD 480 ⁵⁾ 1000 to 5000 lines	 68

¹⁾ Up to 10000 signal periods via integrated 2-fold interpolation
²⁾ Up to 36000 signal periods via integrated 5/10-fold interpolation (higher interpolation upon request)
³⁾ Supply voltage: DC 10 V to 30 V
⁴⁾ Also available with TTL or HTL signal transmission
⁵⁾ Available with mechanical fault exclusion; for deviating specifications and special mounting information, see the *Fault Exclusion* Customer Information document

DRIVE-CLiQ is a registered trademark of Siemens AG.

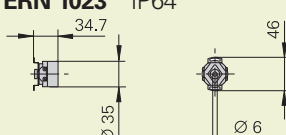
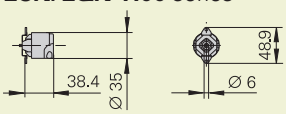
Rotary encoders for motors

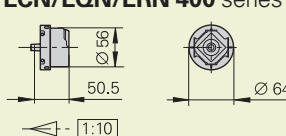
Rotary encoders	Absolute Singletum			Multitum			Incremental	
	Interface	EnDat	Siemens	EnDat	Siemens	□TTL	~ 1V _{PP}	
With integral bearing and mounted stator coupling								
ERN 1023 IP64 	-	-	-	-	-	-	ERN 1023 500 to 8192 lines Three signals for block commutation	-
ECN/EQN 1100 series 	ECN 1123 Positions/rev: 23 bits EnDat 2.2/22 Available with functional safety	ECN 1113 Positions/rev: 13 bits EnDat 2.2/01	ECN 1123S Positions/rev: 23 bits DRIVE-CLiQ Available with functional safety	EQN 1135 Positions/rev: 23 bits 4096 revolutions EnDat 2.2/22 Available with functional safety	EQN 1125 Positions/rev: 13 bits 4096 revolutions EnDat 2.2/01	EQN 1135S Positions/rev: 23 bits 4096 revolutions DRIVE-CLiQ Available with functional safety	-	-
ERN 1123 IP00 	-	-	-	-	-	-	ERN 1123 500 to 8192 lines Three signals for block commutation	-
ECN/EQN/ERN 1300 series IP40 ECN/EQN/ERN 400 series IP64 	ECN 1325 Positions/rev: 25 bits EnDat 2.2/22 EnDat 3/E30-R2 Available with functional safety ECN 425 Positions/rev: 25 bits EnDat 2.2/22 Available with functional safety	ECN 1313 Positions/rev: 13 bits EnDat 2.2/01 ECN 413 Positions/rev: 13 bits EnDat 2.2/01	ECN 1324S Positions/rev: 24 bits DRIVE-CLiQ Available with functional safety	EQN 1337 Positions/rev: 25 bits 4096 revolutions EnDat 2.2/22 EnDat 3/E30-R2 Available with functional safety EQN 437 Positions/rev: 25 bits 4096 revolutions EnDat 2.2/22 Available with functional safety	EQN 1325 Positions/rev: 13 bits 4096 revolutions EnDat 2.2/01 EQN 425 Positions/rev: 13 bits 4096 revolutions EnDat 2.2/01	EQN 1336S Positions/rev: 24 bits 4096 revolutions DRIVE-CLiQ Available with functional safety	ERN 1321 1024 to 4096 lines ERN 1326 1024 to 4096 lines ¹⁾ Three TTL signals for block commutation ERN 421 1024 to 4096 lines	ERN 1381 ²⁾ 512 to 4096 lines ERN 1387 ²⁾ 2048 lines Z1 track for sine commutation ERN 487 2048 lines Z1 track for sine commutation

These rotary encoders are described in the **Encoders for Servo Drives** brochure.



¹⁾ 8192 signal periods through integrated 2-fold interpolation

²⁾ Available with mechanical fault exclusion; for restrictions on specifications and for special mounting information, see the *Fault Exclusion* customer information document

DRIVE-CLiQ is a registered trademark of Siemens AG.

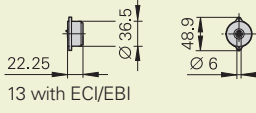
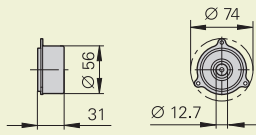
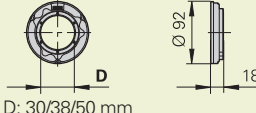
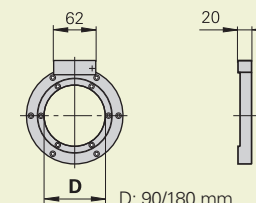
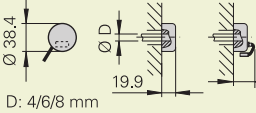
Rotary encoders	Absolute Singletum			Multitum			Incremental	
	Interface	EnDat	Siemens	EnDat	Siemens	□TTL	~ 1 V _{pp}	
Without integral bearing								
ECI/EQI/EBI 1100 series 	ECI 1118 Positions/rev: 18 bits EnDat 2.2/22	ECI 1119 Positions/rev: 19 bits EnDat 2.2/22, EnDat 3/E30-R2 Available with functional safety	–	EBI 1135 Positions/rev: 18 bits 65 536 revolutions (buffer battery backup) EnDat 2.2/22	EQI 1131 Positions/rev: 19 bits 4096 revolutions EnDat 2.2/22, EnDat 3/E30-R2 Available with functional safety	–	–	–
ECI/EQI 1300 series 	ECI 1319 Positions/rev: 19 bits EnDat 2.2/22 EnDat 3/E30-R2 Available with functional safety	ECI 1319 Positions/rev: 19 bits EnDat 3/E30-R2 Available with functional safety	ECI 1319 S Positions/rev: 19 bits DRIVE-CLiQ Available with functional safety	EQI 1331 Positions/rev: 19 bits 4096 revolutions EnDat 2.2/22 EnDat 3/E30-R2 Available with functional safety	EQI 1331 Positions/rev: 19 bits 4096 revolutions EnDat 3/E30-R2 Available with functional safety	EQI 1331 S Positions/rev: 19 bits 4096 revolutions DRIVE-CLiQ Available with functional safety	–	–
ECI/EBI 100 series  D: 30/38/50 mm	ECI 119 Positions/rev: 19 bits EnDat 2.2/22 or EnDat 2.1/01	–	–	EBI 135 Positions/rev: 19 bits 65 536 revolutions (buffer battery backup) EnDat 2.2/22	–	–	–	–
ECI/EBI 4000 series  D: 90/180 mm	ECI 4010 Positions/rev: 20 bits EnDat 2.2/22 Available with functional safety	–	ECI 4090S Positions/rev: 20 bits DRIVE-CLiQ Available with functional safety	EBI 4010 Positions/rev: 20 bits 65 536 revolutions (buffer battery backup) EnDat 2.2/22 Available with functional safety	–	–	–	–
ERO 1400 series  D: 4/6/8 mm	–	–	–	–	–	ERO 1420 512 to 1024 lines ERO 1470 1000/1500 lines ¹⁾	ERO 1480 512 to 1024 lines	–

These rotary encoders are described in the **Encoders for Servo Drives** brochure.



¹⁾ Up to 37 500 signal periods via integrated 5/10/20/25-fold interpolation

DRIVE-CLiQ is a registered trademark of Siemens AG.

Rotary encoders for special applications

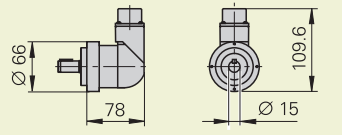
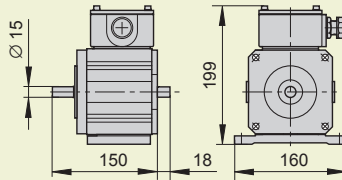
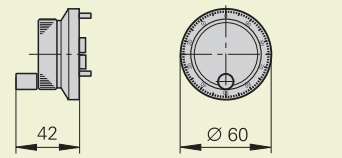
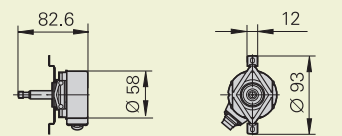
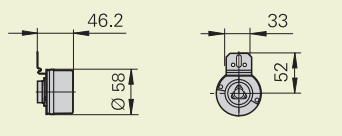
Rotary encoders	Absolute Singletum		Multiturn 4096 revolutions		Incremental			
	Interface	EnDat	SSI	EnDat	SSI	□TTL	□HTL	~ 1V _{pp}
For high bearing loads								
ROD 600 	-	-	-	-	-	ROD 620 512 to 5000 lines	ROD 630 512 to 5000 lines	-
ROD 1930 	-	-	-	-	-	-	ROD 1930 600 to 2400 lines	-
Electronic handwheel								
HR 1120 	-	-	-	-	-	ERN 421 1024 lines	ERN 431 1024 lines	-
For Siemens asynchronous motors								
ERN 401 series 	-	-	-	-	-	HR 1120 100 lines	-	-
EQN/ERN 400 series 	-	-	EQN 425 Positions/rev: 13 bits EnDat 2.1/01	EQN 425 Positions/rev: 13 bits	ERN 420 1024 lines	ERN 430 1024 lines	-	-



74



76

For more information, please refer to the respective Product Information document



78



For more information, please refer to the respective Product Information document



For more information, please refer to the respective Product Information document

Measuring principles

Measuring standards

HEIDENHAIN encoders with **optical scanning** use measuring standards consisting of periodic structures known as graduations. These precision graduations are applied to a carrier substrate made of glass or steel and are manufactured by means of various photolithographic processes. Graduations are made from the following materials:

- Extremely hard chromium lines on glass
- Matte-etched lines on gold-plated steel tape
- Three-dimensional structures on glass or steel substrates

The photolithographic manufacturing processes developed by HEIDENHAIN allow for typical grating periods ranging from 50 µm down to 4 µm.

These processes yield fine grating periods characterized by excellent edge definition and high homogeneity. In combination with the photoelectric scanning method, these characteristics are crucial for attaining high-quality output signals.

The master graduations are manufactured by HEIDENHAIN on custom-built, high-precision dividing engines.

Encoders that use the **inductive scanning principle** employ metal graduations or copper/nickel-based graduation structures. These graduation structures are applied to a printed-circuit carrier material.

Measuring methods

In the **absolute measuring method**, the position value is available immediately upon encoder switch-on and can be requested by the downstream electronics at any time. There is therefore no need to search for the reference position by jogging the axes. The resulting absolute position information **is read from the circular scale**, which exhibits a code structure.



Circular scales of absolute rotary encoders

In the **incremental measuring method**, the graduation consists of a periodic grating structure. Position information is obtained **through the counting** of individual increments (measuring steps) starting from a freely settable point of origin. Since position ascertainment requires an absolute reference, the circular scales have an additional track containing a **reference mark**.



Circular scales of incremental rotary encoders

A separate incremental track is interpolated for the position value and is simultaneously used for generating an optional incremental signal.

Singletum rotary encoders repeat the absolute position information with each revolution. **Multitum encoders** can distinguish between additional revolutions.

The absolute position established by the reference mark is assigned to exactly one measuring step.

Thus, before an absolute reference can be established or the most recently selected reference point can be refound, this reference mark must first be traversed.

Scanning methods

Photoelectric scanning

Most HEIDENHAIN encoders utilize the photoelectric scanning principle. Photoelectric scanning is performed contact-free and thus does not induce wear. This method detects even extremely fine graduation lines down to a width of only a few micrometers and generates output signals with very small signal periods.

The ECN, EQN, ERN, ROC, ROQ, and ROD rotary encoders utilize the imaging scanning principle.

Put simply, the imaging scanning principle uses projected-light signal generation; for example, two gratings (a scale and a scanning reticle) with the same grating period are moved relative to each other. The carrier material of the scanning reticle is transparent. The graduation on the measuring standard can be applied to either a transparent surface or a reflective surface.

When parallel light passes through a grating structure, light and dark fields are projected at a certain interval. At the place where these fields are projected lies an index grating with the same grating period. When these two graduations move relative to each other, the incident light is modulated: If the gaps are aligned, light passes through. If the lines of one grating coincide with the gaps of the other, no light passes through. Photocells convert these light fluctuations into nearly sinusoidal electrical signals. In encoders that use the imaging scanning principle, workable mounting tolerances are attainable starting at a minimum grating period of 10 µm.

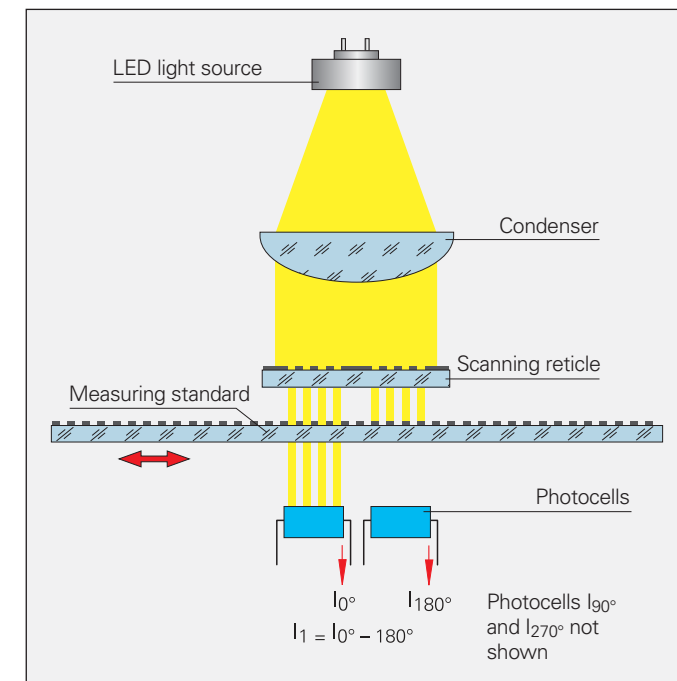

Photoelectric scanning according to the imaging scanning principle

The absolute rotary encoders that use this scanning principle have a single, large, and finely structured photosensor as opposed to a group of discrete photocells. The width of the photosensor's structures is identical to the width of the measuring standard's grating structure. A scanning reticle with a matching structure is therefore not needed.

Other scanning principles

The ECI/EBI/EQI rotary encoders utilize the inductive measuring principle. In this case, the graduation structures modulate the amplitude and phase of a high-frequency signal. By means of circumferential scanning, the position value is always generated based on the signals from the receiver coils that are evenly distributed along the circumference.

Rotary encoder accuracy is primarily determined by the following factors:

- The directional error of the radial grating
- The eccentricity of the circular scale relative to the bearing
- The radial runout of the bearing
- The error arising from connection via a shaft coupling; for rotary encoders with stator coupling, this error lies within the system accuracy
- The interpolation error that arises during signal processing in the integrated or external digitizing and interpolation electronics

The following applies to **incremental rotary encoders** with line counts of up to 5000: The maximum direction error at 20 °C ambient temperature and slow rotation (sampling frequency between 1 kHz and 2 kHz) is within

$$\pm \frac{18^\circ \text{ mech.} \cdot 3600}{\text{Line count } z} \text{ [arc seconds]}$$

which equals

$$\pm \frac{1}{20} \text{ grating period.}$$

In the case of ROD rotary encoders, the 6000 to 10 000 signal periods per revolution are generated via signal doubling. The line count must be considered in determining the system accuracy.

For **absolute rotary encoders**, the accuracy of the absolute position values is provided in the specifications of the respective encoder.

For absolute rotary encoders with **complementary incremental signals**, the accuracy depends on the line count:

Line count	Accuracy
512	±60 arc seconds
2048	±20 arc seconds
2048	±10 arc seconds (ROC 425 with high accuracy)

This accuracy information applies to incremental measurement signals at 20 °C ambient temperature and slow rotation.

Mechanical design types and mounting

Rotary encoders with stator coupling

The **ECN/EQN/ERN** rotary encoders feature integrated bearings and a mounted stator coupling. The stator coupling compensates for radial runout and alignment errors without significantly reducing the accuracy. The rotary encoder shaft is directly connected to the measured shaft. During angular acceleration of the shaft, the stator coupling must absorb only the torque resulting from friction within the bearing. The stator coupling permits a certain amount of axial motion in the measured shaft:

ECN/EQN/ERN 400: ±1 mm

ECN/EQN/ERN 1000: ±0.5 mm

ECN/ERN 100: ±1.5 mm

Mounting

The hollow shaft of the rotary encoder is slid onto the measured shaft and fastened on the rotor side by two screws or three eccentric clamps. Rotary encoders with a hollow through shaft can be clamped on the housing side as well. Particularly well suited for repeated mounting are the ECN/EQN/ERN 1300 series rotary encoders featuring a tapered shaft (see the *Encoders for Servo Drives* brochure). Stator-side mounting is performed on a plane surface without a centering collar. The **universal stator coupling** of the ECN/EQN/ERN 400 accommodates a variety of mounting scenarios; for example, it can be mounted to the motor housing from the outside via the provided threads.

Mechanical fault exclusion is possible for the ECN/EQN/ERN 400 series rotary encoders featuring a standard stator coupling and blind hollow shaft.

Dynamic applications require the highest possible natural frequencies f_N of the system's coupling (see also General mechanical information). These natural frequencies can be attained through the shaft clamping on the flange side and a coupling with four screws. The ECN/EQN/ERN 1000 encoders offer an alternative with two screws and two washers.

Typical natural frequency f_N of the connection with stator-side coupling via four screws:

	Stator coupling	Cable	Flange socket	
			Axial	Radial
ECN/EQN/ERN 400	Standard	1550 Hz	1500 Hz	1000 Hz
	Universal	1400 Hz ¹⁾	1400 Hz	900 Hz
ECN/ERN 100		1000 Hz	–	400 Hz
ECN/EQN/ERN 1000		1500 Hz ²⁾	–	–

¹⁾ Also with fastening via two screws

²⁾ Also with fastening via two screws and washers

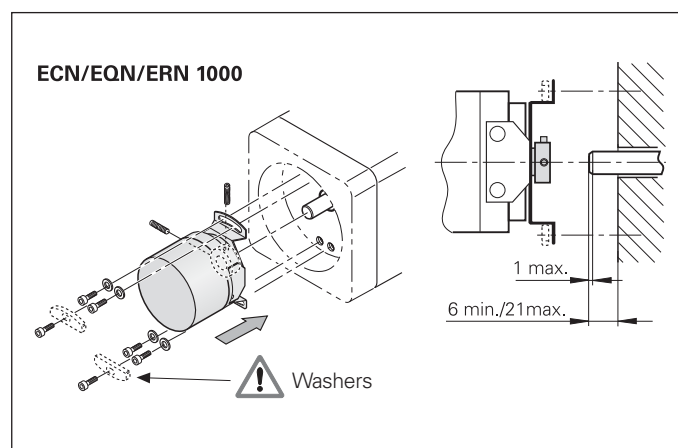
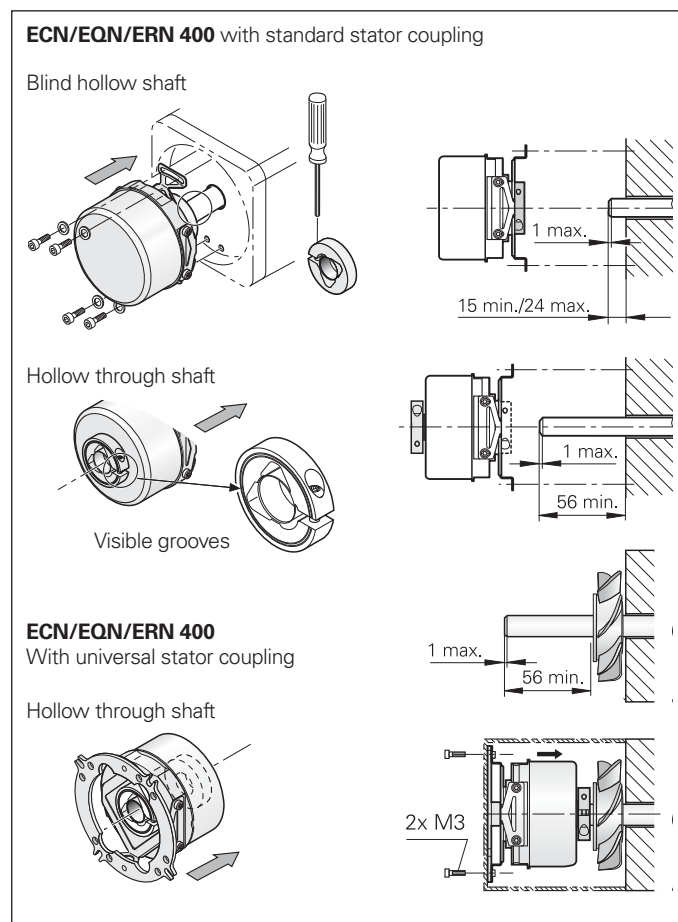
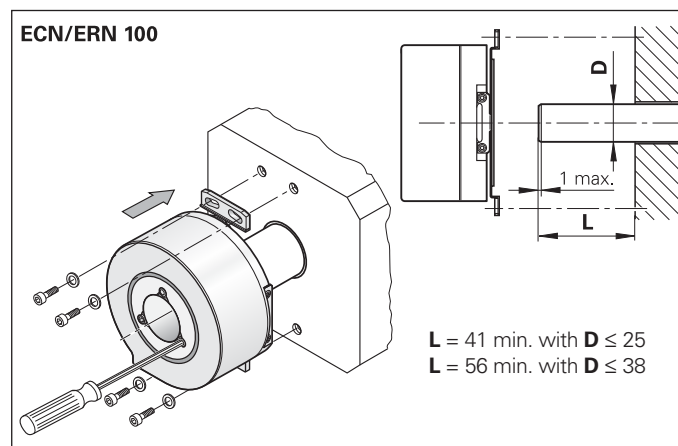

Mounting accessories

Clamping ring

For the ECN/EQN/ERN 400
Through the use of a second clamping ring, the maximum mechanically permissible shaft speed of rotary encoders with a hollow through shaft can be increased up to 12000 rpm.
ID 540741-xx

In the case of safe, hollow-shaft connections, repeated fastening reduces the screw force. In order to maintain the required safety factor for friction-type connections, the maximum number of permissible screw tightening repetitions is limited to four. Beyond this number of repetitions, mechanical fault exclusion cannot be guaranteed. In such cases, new clamping rings must be ordered separately.

Clamping ring for 10 mm ID 540741-06
Clamping ring for 12 mm ID 540741-07

When **high shaft loads** are involved, such as with friction wheels, pulleys, or sprockets, HEIDENHAIN recommends mounting the ECN/EQN/ERN 400 with a bearing assembly.

Bearing assembly

For the ECN/EQN/ERN 400 with blind hollow shaft
ID 574185-03

The bearing assembly is able to absorb large radial shaft loads and prevents overloading of the encoder bearing. On the encoder side, the bearing assembly features a shaft stub with a diameter of 12 mm, thus making it suitable for the ECN/EQN/ERN 400 encoders featuring a blind hollow shaft. The threaded holes for fastening the stator coupling are also already provided. The flange of the bearing assembly has the same dimensions as those of the clamping flange for the ROD 420/430 series. The bearing assembly can be fastened via the threaded holes on its front face or with the aid of the mounting flange or the mounting bracket (see page 21 for both).

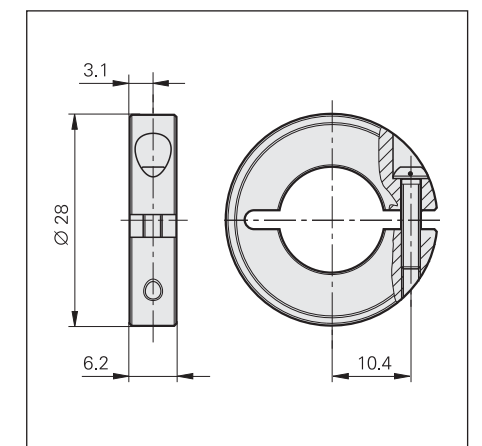
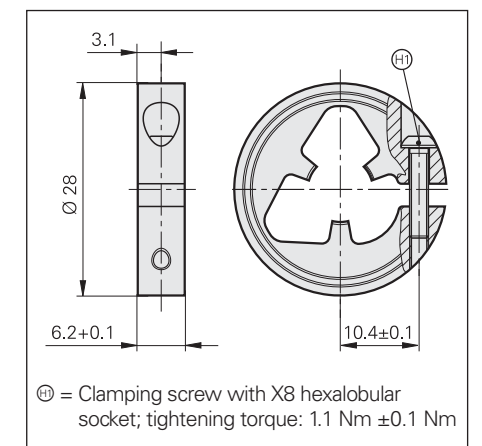

	Bearing assembly
Permiss. shaft speed n	≤ 6000 rpm
Shaft load	Axial: 150 N; radial: 350 N
Operating temperature	–40 °C to 100 °C
Protection EN 60529	IP64

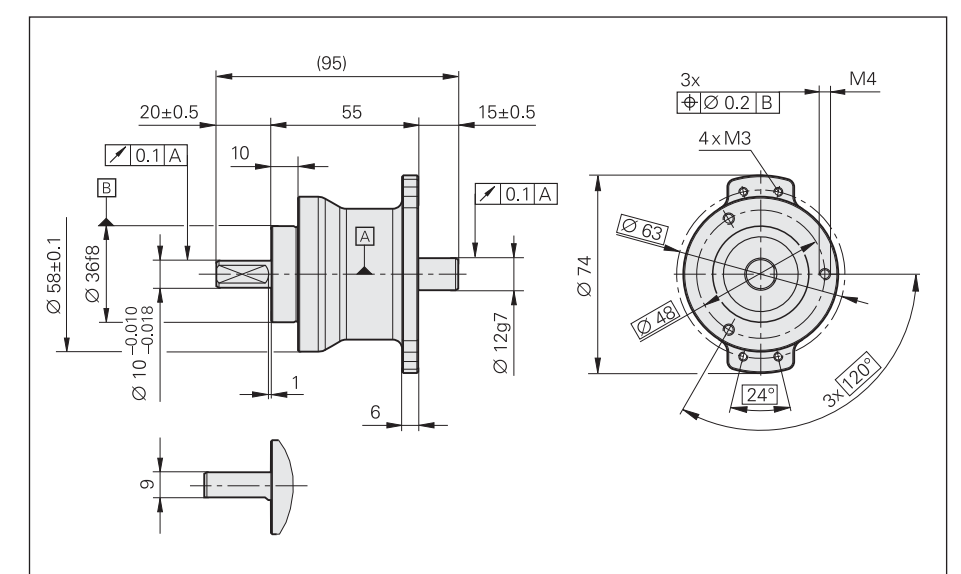

Mounting accessories

Washer

For the ECN/EQN/ERN 1000
For increasing the natural frequency f_N
when fastening with only two screws
ID 334653-01

Torque supports for the ECN/EQN/ERN 400

In simpler applications with the ECN/EQN/ERN 400, the stator coupling can be replaced by torque supports. The following mounting kits are available:

Wire torque support

The stator coupling is replaced by a metal plate to which the included wire is fastened as a coupling.
ID 510955-01

Pin torque support

In place of a stator coupling, a "synchro flange" is fastened via screws. Torque support is provided by a pin mounted axially or radially on the flange. Alternatively, the pin can be inserted on the customer side, and a guide on the encoder's flange is then used for the pin coupling.
ID 510861-01



General accessories

Screwdriver bits

- For HEIDENHAIN shaft couplings
- For ExN 100/400/1000 shaft clampings
- For ERO shaft clampings

Screwdriver

Adjustable torque; accuracy: $\pm 6\%$
0.2 Nm to 1.2 Nm ID 350379-04
1 Nm to 5 Nm ID 350379-05



¹⁾ For DIN 6912 screws
(low head screw with pilot recess)

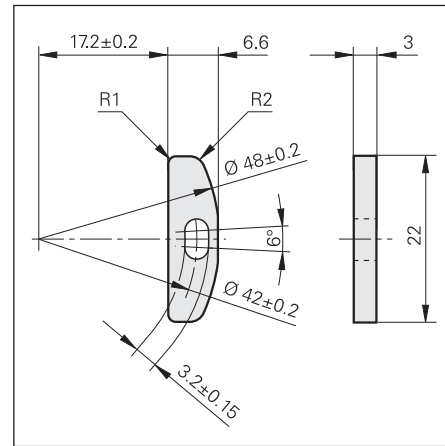

Width across flats	Length	ID
1.5	70 mm	350378-01
1.5 (spherical head)		350378-02
2		350378-03
2 (spherical head)		350378-04
2.5		350378-05
3 (spherical head)		350378-08
4		350378-07
4 (with dog point) ¹⁾		350378-14
TX8	89 mm 152 mm	350378-11 350378-12
TX15	70 mm	756768-42

Rotary encoders for separate shaft coupling

The **ROC/ROQ/ROD** rotary encoders feature an integral bearing and a solid shaft. The encoder shaft is connected to the measured shaft with a separate shaft coupling. This coupling compensates for axial movement and misalignment (radial and angular misalignment) between the rotary encoder and the drive shaft. Thus, the encoder bearing is not subjected to additional external loads, and its service life remains unaffected. Diaphragm and metal bellows couplings are available for rotor-side connection of the ROC/ROQ/ROD encoders (see page 24).

The ROC/ROQ/ROD 400 and ROD 600 series rotary encoders permit high bearing loads (see diagrams). When high loads are involved, such as with friction wheels, pulleys, or sprockets, HEIDENHAIN recommends using an ECN/EQN/ERN 400 mounted to a bearing assembly. For very high bearing loads, the ROD 1930 is a suitable choice.



The shafts to be connected must be mounted with minimum relative offset to each other. For typical mounting tolerances, refer to the "Kinematic transfer error" on page 24.

Bearing service life of the ROC/ROQ/ROD 400

The expected service life of the encoder bearing depends on the shaft load, the point of applied force, and the shaft speed. The *Specifications* provide the maximum shaft loads permitted at the end of the shaft. The relationship between the bearing service life and shaft speed under maximum shaft load for 6 mm and 10 mm shaft diameters is shown in the upper diagram. Under an axial load of 10 N and a radial load of 20 N at the shaft end, the expected bearing service life at maximum shaft speed is greater than 40000 hours.

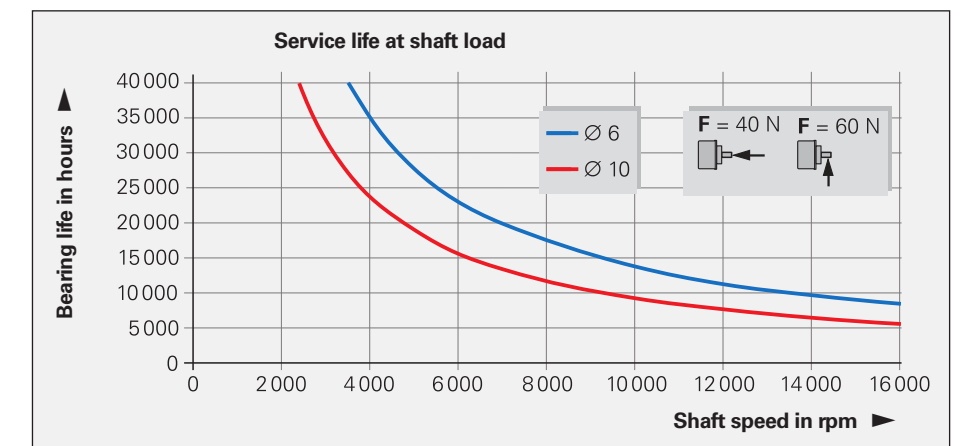

Bearing life of the ROD 600

Rotary encoders of the ROD 600 series are designed for a long service life under high bearing loads.

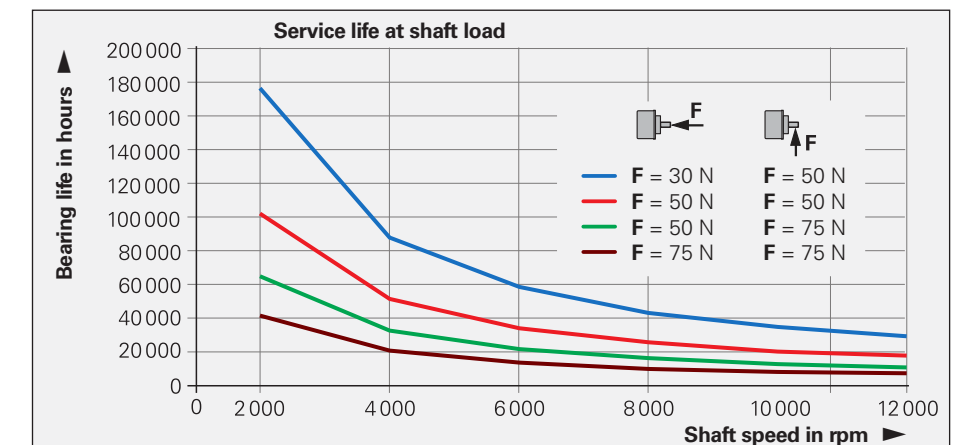

Bearing service life of the ROD 1930

The ROD 1930 is designed for a long service life under very high bearing loads.

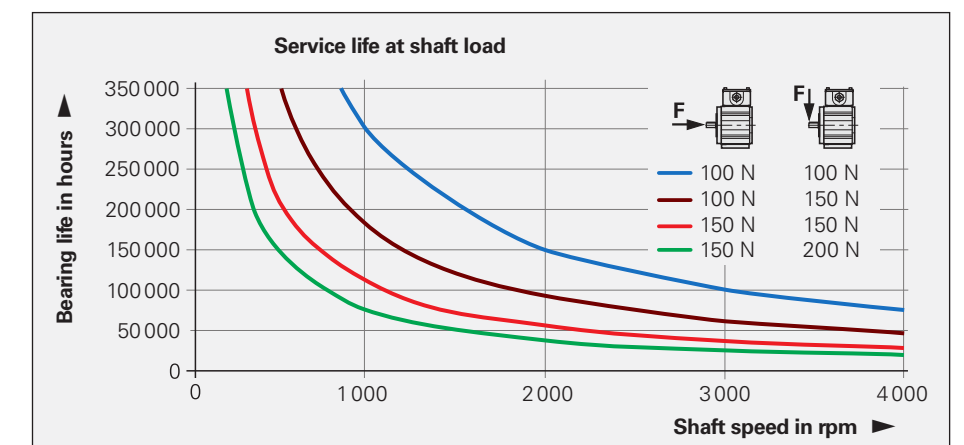

Rotary encoders with synchro flange

Mounting

- Via the synchro flange with three fixing clamps, or
- To an adapter flange via the fastening screw threads on the front face (for ROC/ROQ/ROD 400)

Mechanical fault exclusion is possible upon consultation with HEIDENHAIN in Traunreut, Germany.

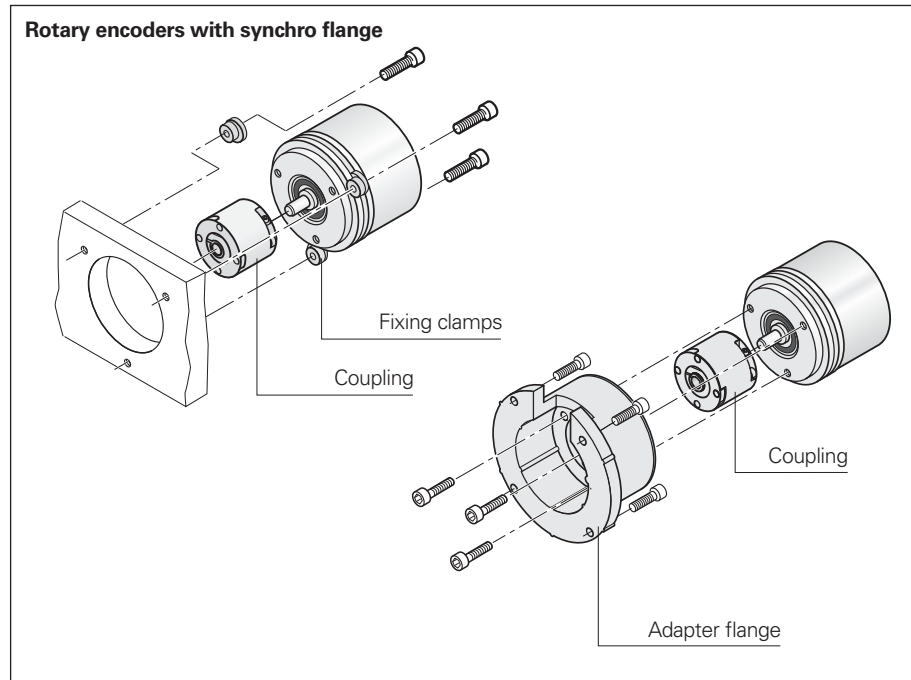

Rotary encoders with clamping flange

Mounting

- To a mounting flange via the fastening threads on the front face, or
- Via clamping on the clamping flange, or
- With three fixing clamps (for encoders with an additional groove on the clamping flange)

Centering is performed via the centering collar on the synchro flange or via the clamping flange.

Mechanical fault exclusion is possible upon consultation with HEIDENHAIN in Traunreut, Germany.

ROC/ROQ/ROD 400 with clamping flange

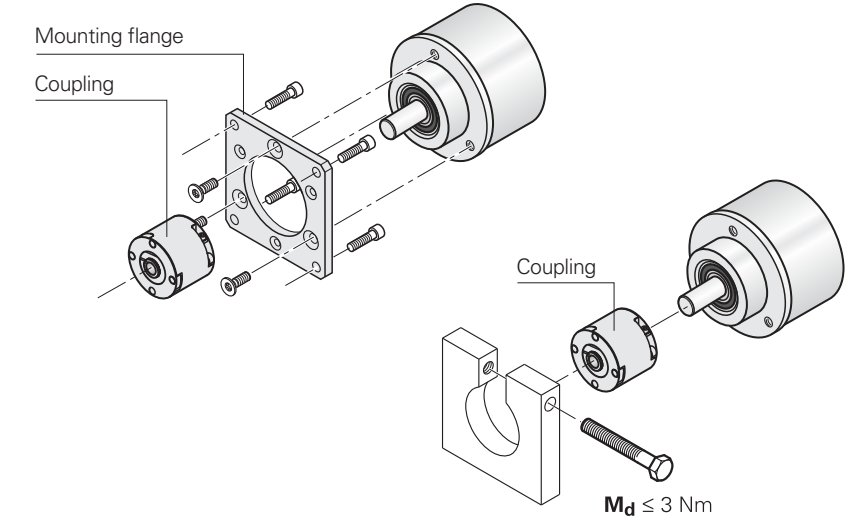

Mounting accessories

Adapter flange

(electrically non-conductive)
ID 257044-01

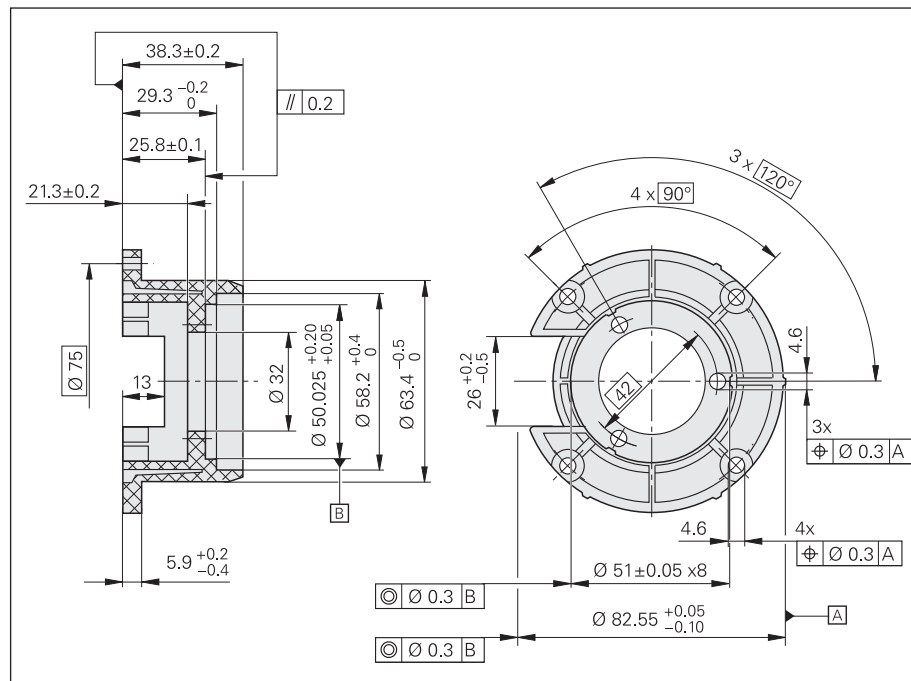

Mounting accessories

Mounting flange

ID 201437-01

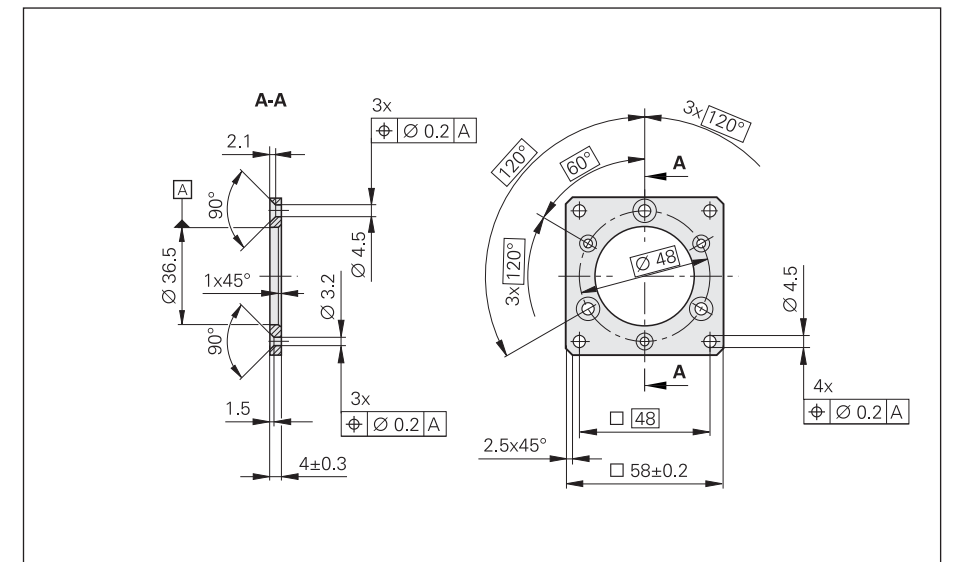

Mounting bracket

ID 581296-01

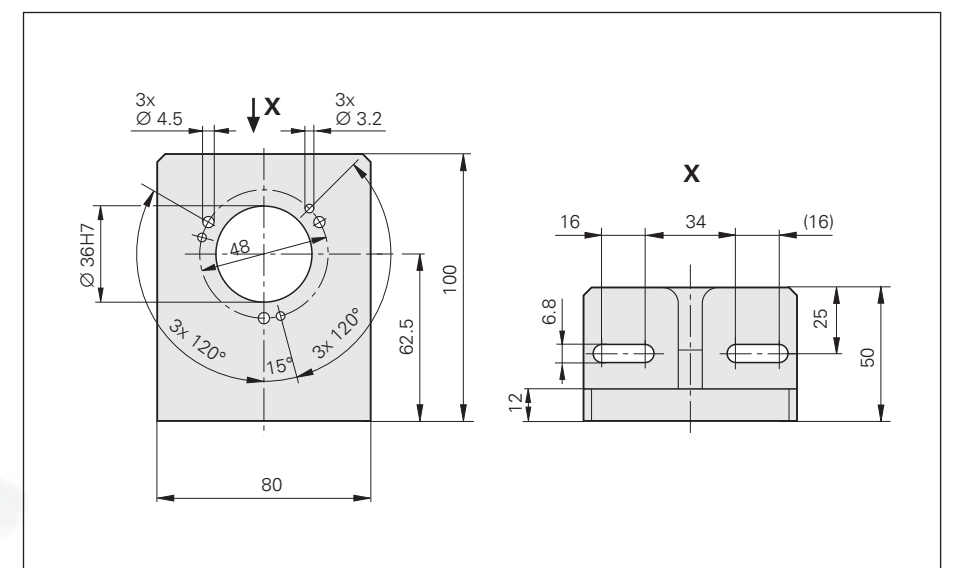

Fixing clamps

For the ROC/ROQ/ROD 400 series
(three per encoder)
ID 200032-01

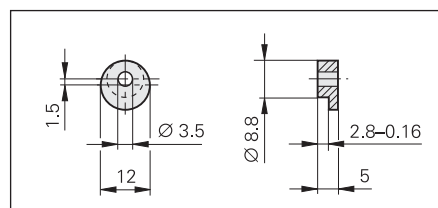

Fixing clamps

For the ROC/ROQ/ROD 1000 series
(three per encoder)
ID 200032-02

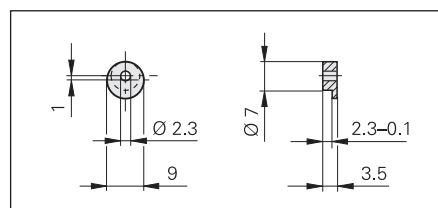

Rotary encoder with flange/base mounting

Mounting

- Via mounting flange, or
 - Via base
- Fastening is performed with four M8 screws.

The terminal box can be mounted at any 90° orientation.

Shaft coupling

For optimum torque transmission, the encoder shaft is equipped with a key. The C19 and C 212 couplings, which are available as accessories, feature a matching keyway.

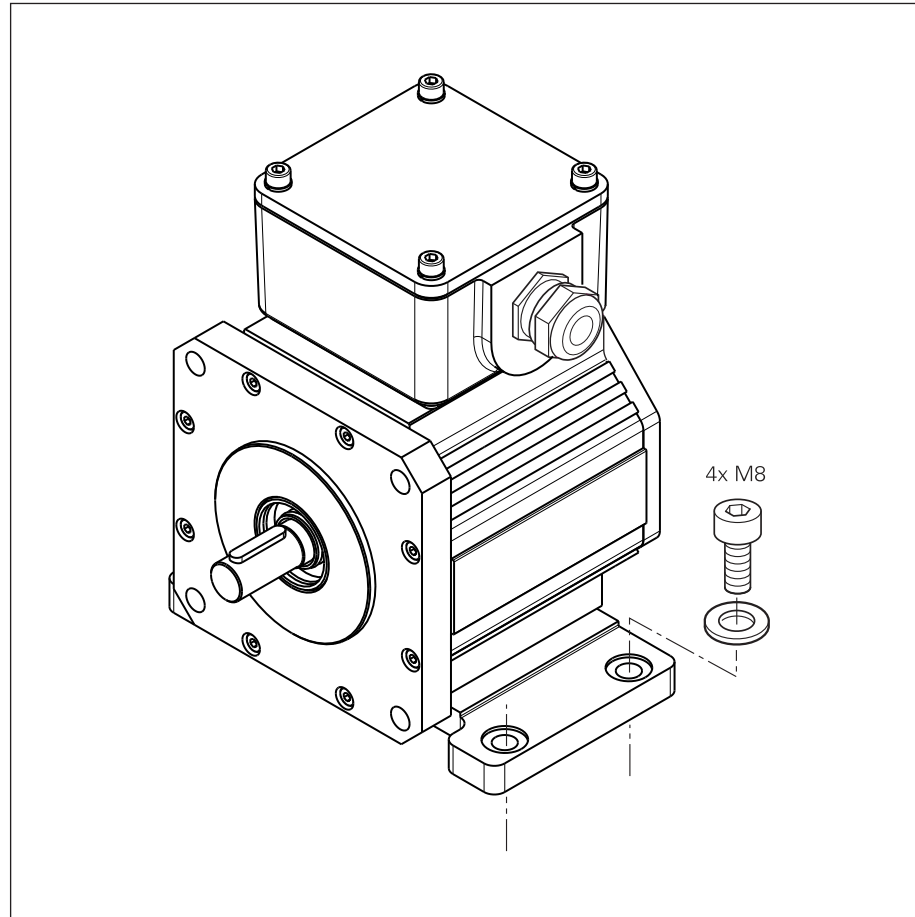

ROD 600 rotary encoder with clamping flange

Mounting

- To a mounting flange via the fastening threads on the front face

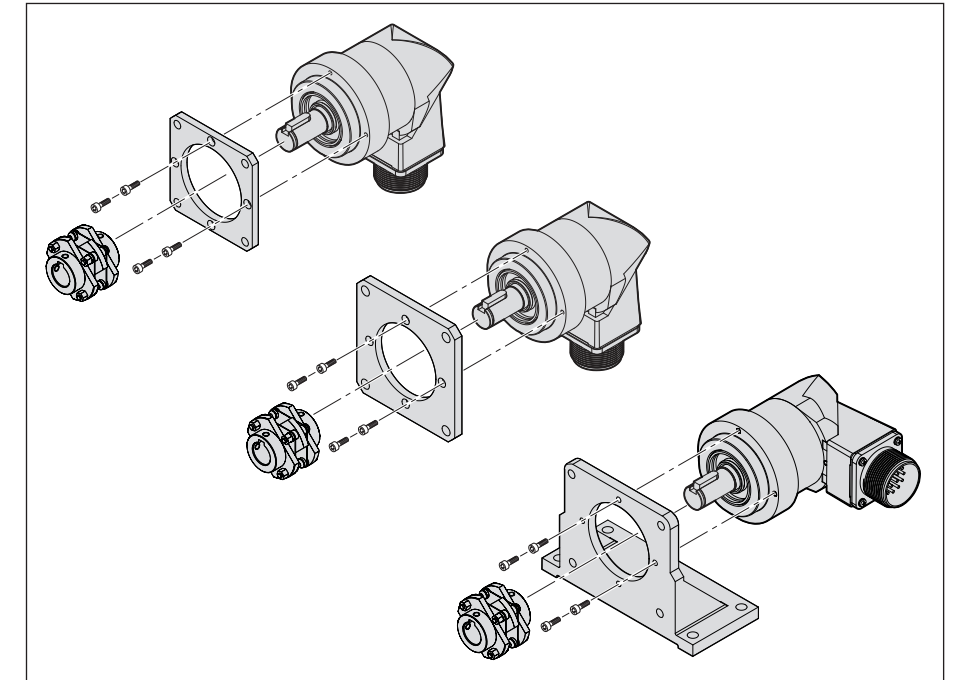

Mounting accessories

Mounting flange, small
ID 728587-01

Mounting flange, large
ID 728587-02

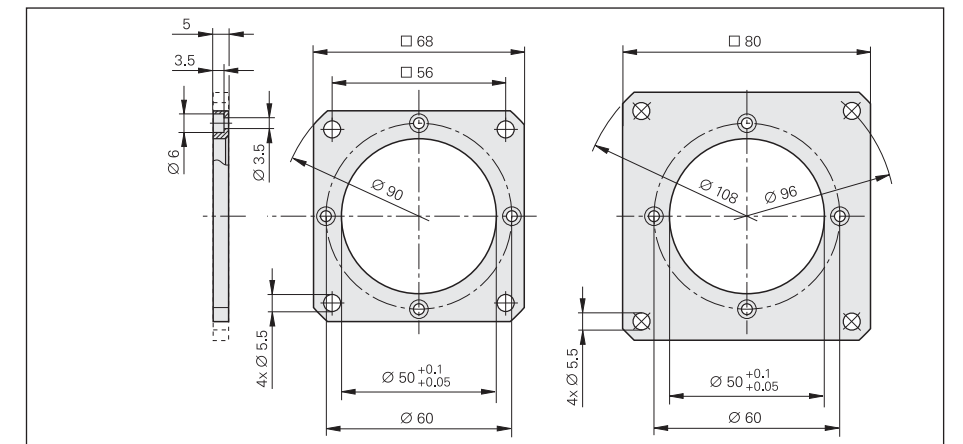

Mounting bracket
ID 728587-03

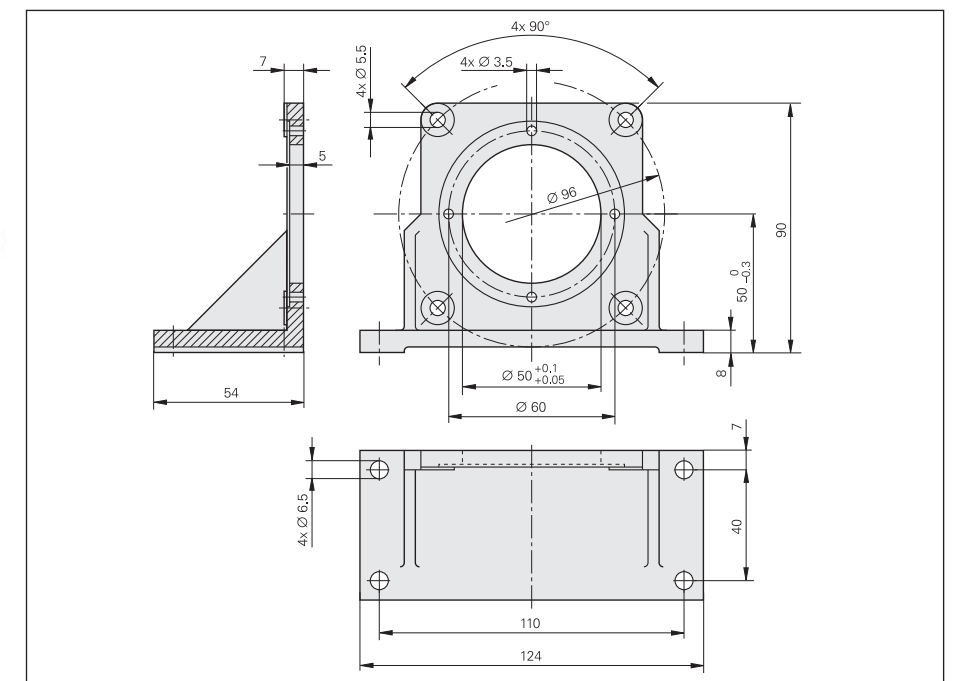

mm
 Tolerancing ISO 8015
 ISO 2768 - m H
 ≤ 6 mm: ±0.2 mm

Shaft couplings

	ROC/ROQ/ROD 400				ROD 1930 ROD 600		ROC/ROQ/ ROD 1000
	Diaphragm coupling				Diaphragm coupling		Metal bellows coupling
	K 14	K 17/01 K 17/06	K 17/02 K 17/04 K 17/05	K 17/03	C 19	C 212	18 EBN 3
Hub bore	6/6 mm	6/6 mm 6/5 mm	6/10 mm 10/10 mm 6/9.52 mm	10/10 mm	15/15		4/4 mm
Galvanic isolation	-	✓	✓	✓	-	✓	-
Kinematic transfer error*	±6"	±10"			±13"		±40"
Torsional rigidity	500 $\frac{\text{Nm}}{\text{rad}}$	150 $\frac{\text{Nm}}{\text{rad}}$	200 $\frac{\text{Nm}}{\text{rad}}$	300 $\frac{\text{Nm}}{\text{rad}}$	1700 $\frac{\text{Nm}}{\text{rad}}$		60 $\frac{\text{Nm}}{\text{rad}}$
Torque	≤ 0.2 Nm	≤ 0.1 Nm		≤ 0.2 Nm	≤ 3.9 Nm	≤ 5 Nm	≤ 0.1 Nm
Radial offset λ	≤ 0.2 mm	≤ 0.5 mm			≤ 0.3 mm		≤ 0.2 mm
Angular error α	≤ 0.5°	≤ 1°			≤ 1.5°		≤ 0.5°
Axial offset δ	≤ 0.3 mm	≤ 0.5 mm			≤ 1.7 mm		≤ 0.3 mm
Moment of inertia (approx.)	$6 \cdot 10^{-6} \text{ kgm}^2$	$3 \cdot 10^{-6} \text{ kgm}^2$		$4 \cdot 10^{-6} \text{ kgm}^2$	$15 \cdot 10^{-6} \text{ kgm}^2$		$0.3 \cdot 10^{-6} \text{ kgm}^2$
Permiss. shaft speed	16000 rpm				20000 rpm	6000 rpm	12000 rpm
Tightening torque of clamping screws (approx.)	1.2 Nm				1.37 Nm		0.8 Nm
Mass	35 g	24 g	23 g	275 g	75 g		9 g

* With typical mounting tolerances: radial offset $\lambda = 0.1 \text{ mm}$; angular error $\alpha = 0.09^\circ$ (0.15 mm over 100 mm)

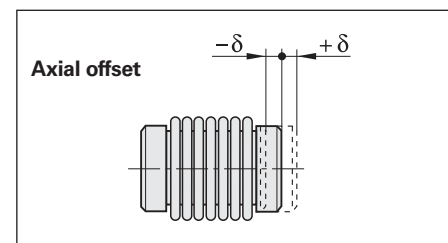
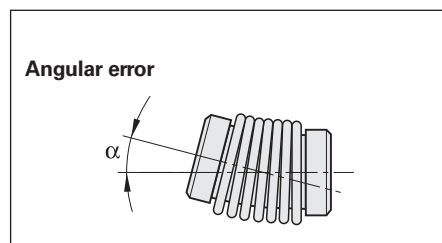
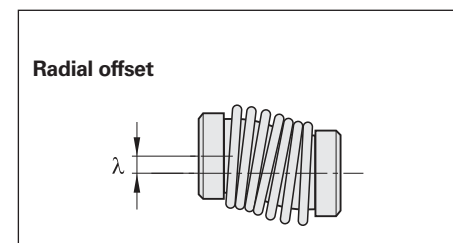

Mounting accessories

Screwdriver bits

Screwdriver

See page 18.

18 EBN 3 metal bellows coupling
For the ROC/ROQ/ROD 1000 series
with **4 mm shaft diameter**
ID 200393-02

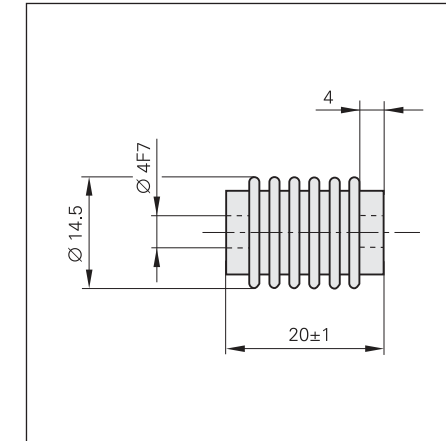

K 14 diaphragm coupling
For the ROC/ROQ/ROD 400
with **6 mm shaft diameter**
ID 293328-01

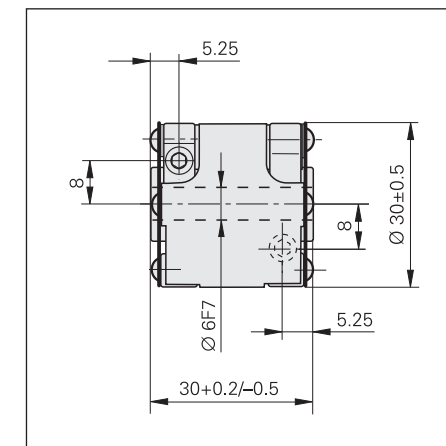

Recommended fit for the mating shaft: h6

Diaphragm coupling K 17
With galvanic isolation
For the ROC/ROQ/ROD 400 series
with **6 mm or 10 mm shaft diameter**
ID 1246841-xx

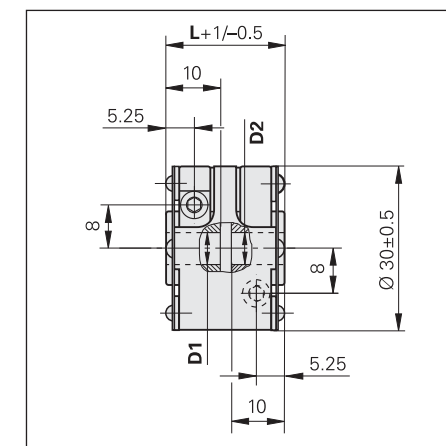

K 17 Variant	D1	D2	L
01	Ø 6 F7	Ø 6 F7	22 mm
02	Ø 6 F7	Ø 10 F7	22 mm
03	Ø 10 F7	Ø 10 F7	30 mm
04	Ø 10 F7	Ø 10 F7	22 mm
05	Ø 6 F7	Ø 9.52 F7	22 mm
06	Ø 5 F7	Ø 6 F7	22 mm

mm
Tolerancing ISO 8015
ISO 2768 - m H
≤ 6 mm: ±0.2 mm

General mechanical information

C 19 diaphragm coupling

For the ROD 1930 and ROD 600 rotary encoders with 15 mm shaft diameter and key ID 731374-01

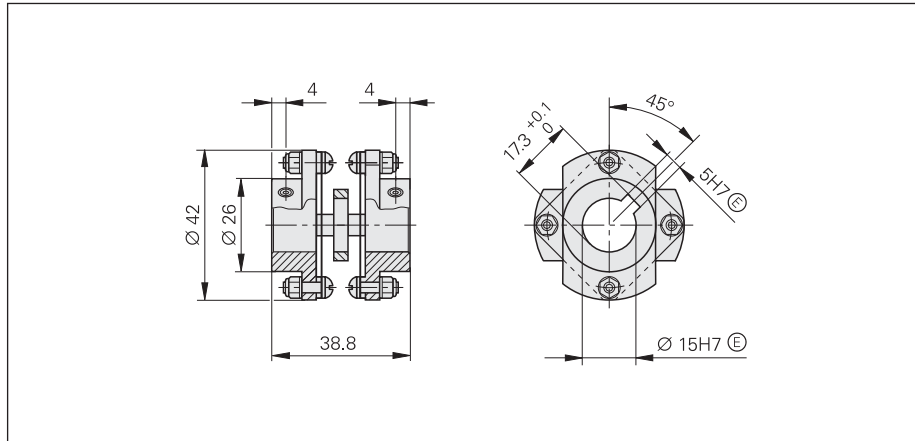

C 212 diaphragm coupling

With galvanic isolation
For the ROD 1930 and ROD 600 rotary encoders with 15 mm shaft diameter and key ID 731374-02

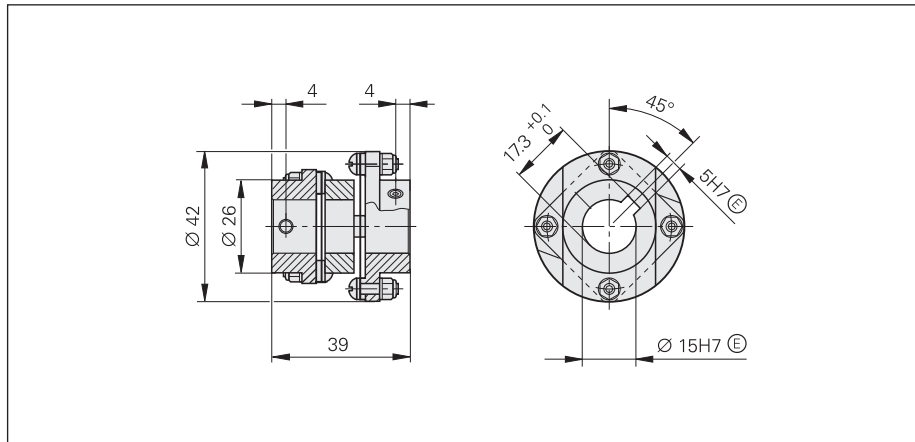

mm
Tolerancing ISO 8015
ISO 2768 - m H
≤ 6 mm: ±0.2 mm

Certification by NRTL (Nationally Recognized Testing Laboratory)

All of the rotary encoders in this brochure comply with the UL safety regulations for the U.S. and with the CSA safety regulations for Canada.

Accelerations

During mounting and operation, encoders are subjected to various types of acceleration.

• Vibration

The encoders are qualified on a test stand under the acceleration values stated in the specifications at frequencies of 55 Hz to 2000 Hz in accordance with EN 60068-2-6. However, if the application or mounting situation causes long-duration resonant vibration, then proper functioning of the encoder may be impaired, or the encoder itself may incur damage.

Thorough testing of the complete system is therefore required.

• Shock

The encoders are qualified on a test stand under the acceleration values stated in the specifications and under the exposure times in accordance with EN 60068-2-27 for non-repetitive, semi-sinusoidal shock. **Continuous shock loads** are therefore not covered and **must be tested in the application.**

- The **maximum angular acceleration** is 10^5 rad/s^2 . This is the maximum permissible angular acceleration of the rotor without the encoder incurring damage. The actual attainable angular acceleration is within the same order of magnitude but can vary depending on the type of shaft connection (for deviating values for the ECN/ERN 100, see the *Specifications*). An adequate safety factor must be determined through system tests.

Deviating values for rotary encoders with functional safety are provided in the corresponding Product Information documents.

Humidity

The maximum permissible relative humidity is 75 %. A relative humidity of 93 % is temporarily permissible. Condensation is not permissible.

Magnetic fields

Magnetic fields > 30 mT can affect encoder functioning. Please contact HEIDENHAIN in Traunreut, Germany, as needed.

Natural frequencies

With the ROC/ROQ/ROD rotary encoders, the rotor and the shaft coupling together form an oscillation-capable spring-mass system. In the case of the ECN/EQN/ERN, this applies to the stator and stator coupling.

The **natural frequency f_N** should be as high as possible. In order for the highest possible natural frequency to be attained with the **ROC/ROQ/ROD rotary encoders**, a diaphragm coupling with a high torsional rigidity C must be used (see *Shaft couplings*).

$$f_N = \frac{1}{2 \times \pi} \cdot \sqrt{\frac{C}{I}}$$

f_N : Natural frequency of the coupling in Hz
C: Torsional rigidity of the coupling in Nm/rad
I: Moment of inertia of the rotor in kgm^2

In conjunction with the stator coupling, the **ECN/EQN/ERN** rotary encoders form an oscillation-capable spring-mass system whose **natural frequency f_N** of the coupling in the direction of measurement should be as high as possible. The natural frequency of the coupling is influenced by the rigidity of the stator coupling and by the customer-side mounting situation. The stated typical natural frequencies may vary depending on the encoder variant (e.g., singleturn or multiturn), production tolerances, and differing mounting conditions. If radial and/or axial acceleration forces also come into play, then the rigidity of the encoder bearing and of the encoder stator has an effect as well. If such loads occur within your application, HEIDENHAIN recommends consulting with the main facility in Traunreut.

HEIDENHAIN generally recommends determining the natural frequency of the stator coupling in the complete system.

Starting torque and operating torque

The starting torque is the torque required to put the rotor into motion from standstill. If the rotor is already rotating, then a certain operating torque is acting on the encoder. The starting torque and operating torque are influenced by various factors, such as the temperature, prior standstill time, and the amount of wear on the bearings and seals.

The typical values stated in the specifications are mean values based on encoder-specific test series performed at room temperature and at a stabilized operating temperature. The typical operating torques are also based on constant shaft speeds. For applications in which the torque has a significant influence, HEIDENHAIN recommends consulting with the main facility in Traunreut.

Protection against contact (EN 60529)

After completed installation of the encoder, any rotating parts must be sufficiently protected from unintentional contact during operation.

Protection (EN 60529)

The ingress of contamination can impair proper functioning of the encoder. Unless otherwise indicated, all of the rotary encoders have an IP64 rating (ExN/ROx 400: IP67) in accordance with EN 60529. These specifications apply to the housing, cable outlet, and flange socket versions when engaged.

The **shaft inlet** meets an IP64 rating. Splash water must not be allowed to have any harmful effect on the encoder's parts. If the protection rating of the shaft inlet is not sufficient (e.g., due to vertical mounting of the encoder), then the encoders should be additionally protected with labyrinth seals. Many encoders are also available with an IP66 rating for the shaft inlet. Depending on the application, the radial shaft seal rings used for sealing are subjected to wear due to friction.

Noise emission

Running noise can occur during operation. This is particularly true of encoders with integral bearing and multiturn rotary encoders (with gears). The intensity may vary depending on the mounting situation and shaft speed.

System tests

Encoders from HEIDENHAIN are usually integrated as components into complete systems. Such applications require **comprehensive testing of the complete system**, irrespective of the encoder's specifications.

The specifications provided in this brochure apply only to the encoder and not to the complete system. Any operation of the encoder outside of the specified range or outside of its proper and intended use is solely at the user's own risk.

Mounting

The steps and dimensions that must be complied with during mounting are specified solely in the mounting instructions supplied with the device. All mounting-related information in this brochure is therefore only provisional and non-binding, and will not become the subject matter of a contract.

All provided information on screw connections assumes a mounting temperature of 15 °C to 35 °C.

Screws with material bonding anti-rotation lock

Mounting screws and central screws from HEIDENHAIN (not included in delivery) feature a coating that, after hardening, provides a material bonding anti-rotation lock. As a result, these screws cannot be reused. Their minimum shelf life is two years (storage at ≤ 30 °C and ≤ 65 % relative humidity). Their expiration date is printed on the package.

Screw insertion and the application of tightening torque must therefore be completed within five minutes. The required strength is reached at room temperature after six hours. The lower the temperature, the longer the curing process will take. Curing temperatures below 5 °C are not permissible.

Screws with material bonding anti-rotation lock must not be used more than once. If a replacement becomes necessary, recut the threads and use new screws. On threaded holes, a chamfer is required in order to keep the adhesive coating from being scraped off.

For the fault exclusion design for functional safety, the following material properties and conditions for the mating surfaces are assumed.

	Aluminum	Steel
Material type	Hardenable wrought aluminum alloys	Unalloyed hardened steel
Tensile strength R_m	≥ 220 N/mm ²	≥ 600 N/mm ²
Yield strength $R_{p0.2}$ or yield point R_e	Not applicable	≥ 400 N/mm ²
Shear strength τ_a	≥ 130 N/mm ²	≥ 390 N/mm ²
Interface pressure p_G	≥ 250 N/mm ²	≥ 660 N/mm ²
Elastic modulus E (at 20 °C)	70 kN/mm ² to 75 kN/mm ²	200 kN/mm ² to 215 kN/mm ²
Coefficient of thermal expansion α_{therm} (at 20 °C)	≤ 25 · 10 ⁻⁶ K ⁻¹	10 · 10 ⁻⁶ K ⁻¹ to 17 · 10 ⁻⁶ K ⁻¹
Surface roughness Rz	≤ 16 μm	
Friction values	Mounting surfaces must be clean and free of grease. Use screws and washers in their condition as delivered.	
Tightening procedure	Use a signal-emitting torque wrench in accordance with DIN EN ISO 6789, with an accuracy of ±6 %	
Mounting temperature	15 °C to 35 °C	

Rotary encoders can exert a torque of 1 Nm on the mating shaft. The mating mechanics must be designed for this load. If further requirements must be complied with, then these are provided in the respective Product Information document.

Modifications to the encoder

The proper functioning and accuracy of encoders from HEIDENHAIN are ensured only if the encoders have not been modified. Any modification, even a minor one, can impair the proper functioning, reliability, and safety of the encoders, and result in a loss of warranty. This also includes the use of any additional or non-prescribed locking varnishes, lubricants (e.g., for screws), or adhesives. If you are in doubt, we recommend that you consult with HEIDENHAIN in Traunreut, Germany.

Conditions for longer storage times

For a storage period of twelve months or longer, HEIDENHAIN recommends the following:

- Leave the encoders in their original packaging
- The storage location should be dry, free of dust, and temperature-regulated. It should also be free of vibration, mechanical shock, and chemical environmental influences
- Every twelve months, rotate the shafts of the encoders with integral bearing at low speed and without axial or radial shaft loading so that the bearing lubrication becomes evenly redistributed (e.g., such as when first breaking in an encoder)

Parts subject to wear

Encoders from HEIDENHAIN are designed for a long service life. Preventive maintenance is not required. However, they do contain components that are subject to wear, depending on the application and how they are deployed. This especially applies to cables that are subjected to frequent flexing. Other parts subject to wear are the bearings in encoders with integral bearing, the radial shaft seal rings in rotary encoders and angle encoders, and the sealing lips on linear encoders.

In order to avoid damage from current flows, some rotary encoders are available with hybrid bearings. In general, these bearings exhibit greater wear at high temperatures than standard bearings.

Service life

Unless otherwise specified, HEIDENHAIN encoders are designed for a service life of 20 years, which is equivalent to 40000 operating hours under typical operating conditions.

Temperature ranges

For encoders still in their packaging, a **storage temperature range** of -30 °C to 65 °C applies (HR 1120: -30 °C to 70 °C).

The **operating temperature range** specifies the temperatures that a rotary encoder is permitted to reach during operation in the actual installation environment. Within this range, proper functioning of the rotary encoder is ensured. The operating temperature is measured at the defined measuring point (see dimension drawing) and must not be confused with the ambient temperature.

The temperature of the rotary encoder is influenced by the following factors:

- The mounting conditions
- The ambient temperature
- The encoder's susceptibility to self-heating

An encoder's susceptibility to self-heating depends both on its design characteristics (stator coupling / solid shaft, shaft sealing ring, etc.) and on its operating parameters (shaft speed, supply voltage). A temporary period of heightened self-heating can also occur after very long breaks in operation (of several months). Please allow for a two-minute break-in period at low shaft speeds. The greater susceptibility to self-heating that an encoder exhibits, the lower the ambient temperature needs to be in order to keep the encoder within its permissible operating temperature range.

This table shows the approximate self-heating values to be expected for the rotary encoders. In the worst case, the amount of self-heating may be affected by multiple operating parameters, such as a 30 V supply voltage and maximum shaft speed. Thus, if an encoder is being operated close to its maximum permissible specifications, then the actual operating temperature should be measured directly at the encoder. Suitable measures must then be taken (fan, heat sinks, etc.) to sufficiently reduce the ambient temperature so that the maximum permissible operating temperature will not be exceeded during continuous operation.

For high shaft speeds at the maximum permissible ambient temperature, special versions with a reduced protection rating are available (without a radial shaft seal ring and its concomitant frictional heat).

Self-heating at shaft speed n_{max}

<i>Solid shaft / tapered shaft</i> ROC/ROQ/ROD/ ExN 400/1300	≈ +5 K ≈ +10 K with IP66 rating
ROD 600	≈ +75 K
ROD 1900	≈ +10 K
<i>Blind hollow shaft</i> ECN/EQN/ERN 400/1300	≈ +30 K ≈ +40 K with IP66 rating
ECN/EQN/ERN 1000	≈ +10 K
<i>Hollow through shaft</i> ECN/ERN 100 ECN/EQN/ERN 400	≈ +40 K with IP64 rating ≈ +50 K with IP66 rating

Typical self-heating values of a rotary encoder at maximum permissible shaft speed based on its design characteristics. The relationship between shaft speed and heat generation is nearly linear.

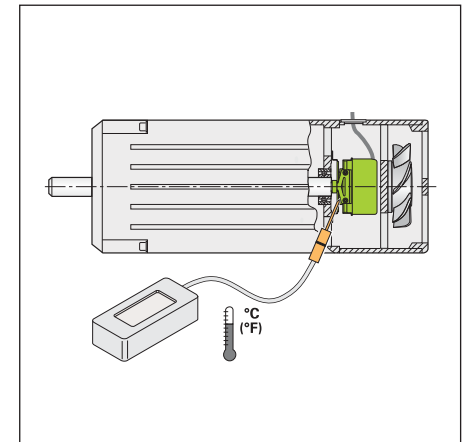

Measuring the actual operating temperature at the defined measuring point of the rotary encoder (see *Specifications*)

Safety-related position measuring systems

The term “functional safety” designates HEIDENHAIN encoders that are suitable for deployment in safety-related applications. These encoders operate as single-encoder systems with purely serial data transmission via the EnDat 2.2 or DRIVE-CLiQ interface. The reliable transmission of the position is based on two independently generated absolute position values and on error bits provided to the safe control.

Basic principle

HEIDENHAIN measuring systems for safety-related applications are tested for compliance in accordance with the standards EN ISO 13849-1 (successor to EN 954-1), EN 61508, and EN 61800-5-2. In these standards, the assessment of safety-related systems is based on, among other things, the failure probabilities of integrated components and subsystems. This modular approach makes it easier for the manufacturers of safety-related systems to realize their complete systems, allowing them to build upon already qualified subsystems. Safety-related position measuring systems with purely serial data transmission via EnDat 2.2 or DRIVE-CLiQ take this approach into account. In a safe drive system, the safety-related position measuring system represents such a subsystem. A **safety-related position measuring system** (e.g., with EnDat 2.2) consists of the following:

- An encoder with an EnDat 2.2 transmission component
- A data transfer line with EnDat 2.2 communication and HEIDENHAIN cable
- An EnDat 2.2 receiver component with monitoring functionality (EnDat Master)

In practice, the **complete “safe drive system”** (e.g., for EnDat 2.2) consists of the following:

- A safety-related position measuring system
- A safety-related control (including the EnDat Master with monitoring functions)
- A power stage with motor power cable and motor
- A mechanical connection between the encoder and motor (e.g., rotor/stator connection)

Area of application

Safety-related position measuring systems from HEIDENHAIN are designed to be usable as single-encoder systems in applications with control category SIL 2 (as per EN 61508), PL d, Category 3 (as per EN ISO 13849).

Additional measures in the control enable the use of certain encoders for applications with up to SIL 3, PL e, Category 4. The suitability of these encoders is indicated in the documentation (brochures and Product Information documents).

The functions of the safety-related position measuring system can be used for the following safety tasks of the complete system (see also EN 61800-5-2):

SS1	Safe Stop 1
SS2	Safe Stop 2
SOS	Safe Operating Stop
SLA	Safely Limited Acceleration
SAR	Safe Acceleration Range
SLS	Safely Limited Speed
SSR	Safe Speed Range
SLP	Safely Limited Position
SLI	Safely Limited Increment
SDI	Safe Direction
SSM	Safe Speed Monitor

Safety functions according to EN 61800-5-2

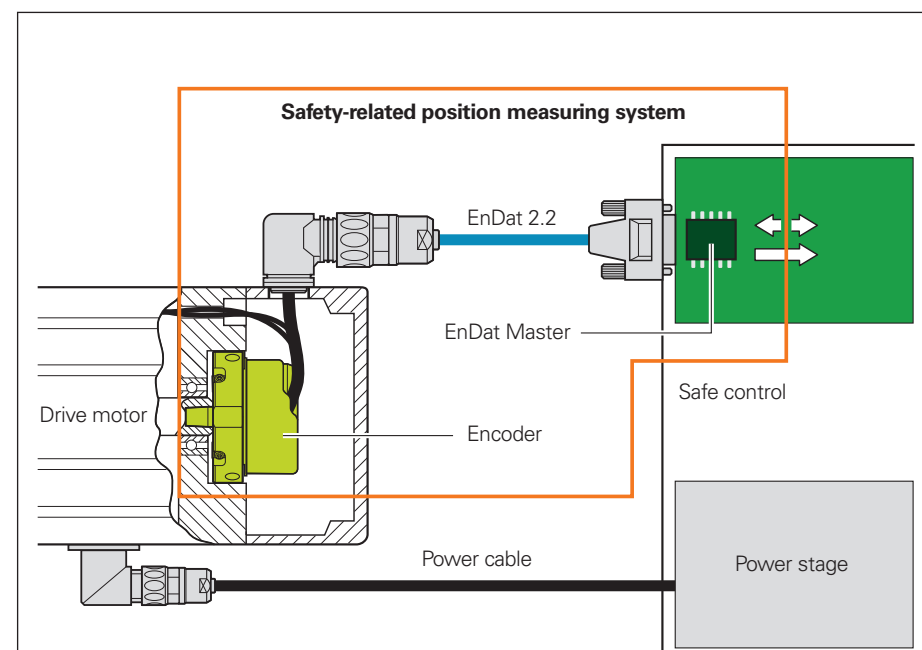

Complete safe drive system with EnDat 2.2

Principle of operation

The safety design of the position measuring system is based on two mutually independent position values generated in the encoder, and on additional error bits. With EnDat 2.2, for example, these data are transmitted to the EnDat Master via the EnDat 2.2 protocol. The EnDat Master performs various monitoring functions that help detect errors in the encoder and data transmission. For example, a comparison of the two position values is performed. The EnDat Master then makes the data available to the safe control. The control monitors the functionality of the safety-related position measuring system through periodically triggered tests.

The architecture of the EnDat 2.2 protocol enables the processing of all safety-relevant information or control mechanisms during unimpaired normal operation. This is possible because the safety-relevant information is contained within the so-called additional data. According to EN 61508, the architecture of the position measuring system is regarded as a single-channel tested system.

Integration of the position measuring system: documentation

In order for a position measuring system to be used properly, demands are placed on the control, machine designer, installation technician, servicing personnel, and others. The required information is provided in the documentation for the position measuring systems.

In order to be able to implement a position measuring system in a safety-related application, a suitable control is required. The control performs the essential tasks of carrying out communication with the encoder and reliably evaluating the encoder data.

The requirements for integrating the EnDat Master with monitoring functions into the safe control are described in HEIDENHAIN Document 533095. For example, this document contains requirements pertaining to the electrical connection, cyclic tests of the position measuring system, and the evaluation and further processing of position values. Supplementing this, Document 1000344 describes measures that enable the use of suitable encoders in applications with up to SIL 3, PL e, Category 4.

Machine and equipment manufacturers need not attend to these details themselves. This functionality must be provided by the control. Product information documents, brochures, and mounting instructions provide information to aid in the selection of a suitable encoder. The **Product Information document** and **brochure** contain general information on the functionality and application of the encoders, as well as specifications and permissible ambient conditions. The **mounting instructions** provide detailed information about installing the encoders.

The architecture of the safety system and the diagnostic capabilities of the control may define or specify further requirements.

Thus, in the operating instructions for the control, it must be explicitly stated whether fault exclusion is required for the loosening of the mechanical connection between the encoder and the motor. Any resulting requirements must be relayed by the machine designer to the installation technician and the servicing staff, for example.

Fault exclusion for the loosening of the mechanical connection

Irrespective of the interface, many safety designs require a safe mechanical connection of the encoder. The standard for electric motors, EN 61800-5-2, defines the loosening or loss of the mechanical connection between the encoder and motor as a fault that requires consideration. In many cases, fault exclusion is required because the control is not necessarily capable of detecting such errors.

Standard encoders

In addition to those encoders explicitly qualified for safety applications, standard encoders (e.g., with 1 V_{PP} signals) can be used in safe applications as well. In such cases, the characteristics of the encoders must be matched to the requirements of the respective control. To this end, HEIDENHAIN can provide additional data about the individual encoders (failure rate, fault model as per EN 61800-5-2).

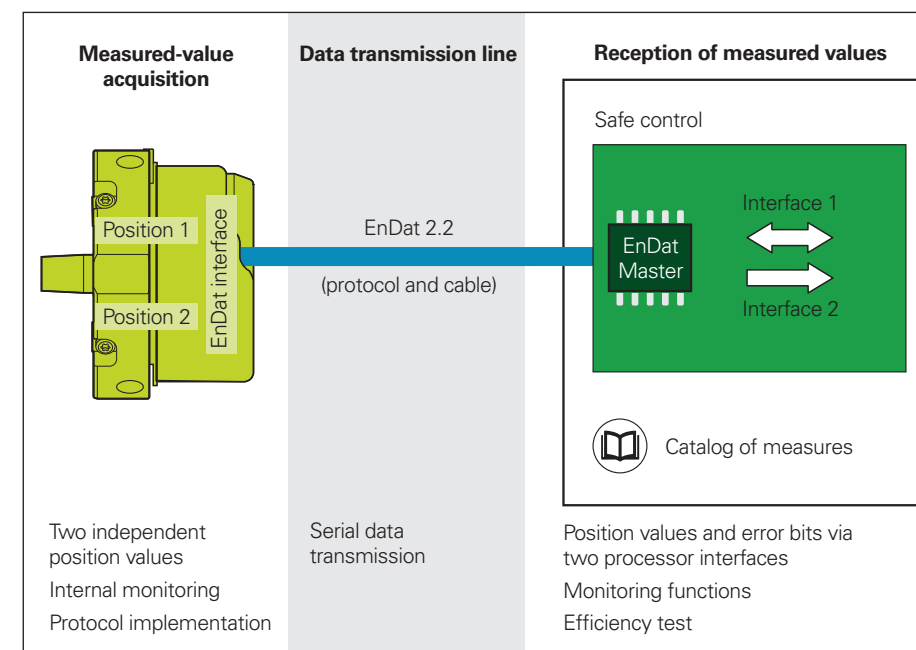

Safety-related position encoder with EnDat 2.2



Further information:

For more information on the topic of functional safety, please refer to the Technical Information documents *Safety-Related Position Measuring Systems* and *Safety-Related Control Technology*, as well as the Product Information documents for encoders with functional safety, and to the Customer Information documents on fault exclusion.

ECN/EQN/ERN 1000 series

Absolute and incremental rotary encoders

- Stator coupling for plane surface
- Blind hollow shaft

ECN/EQN

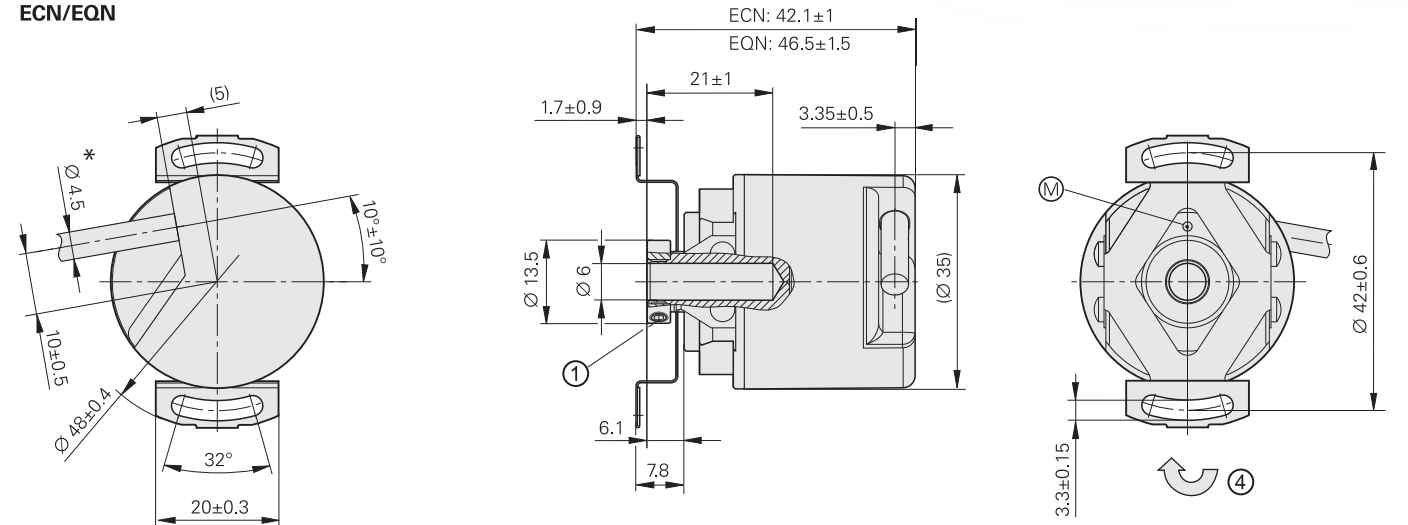

ERN

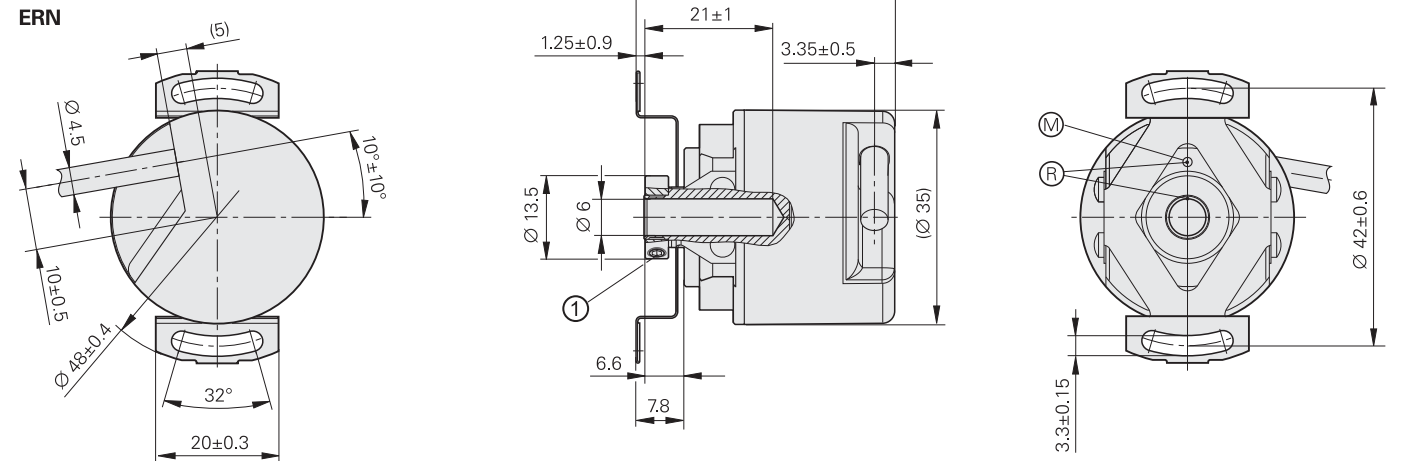

Required mating dimensions

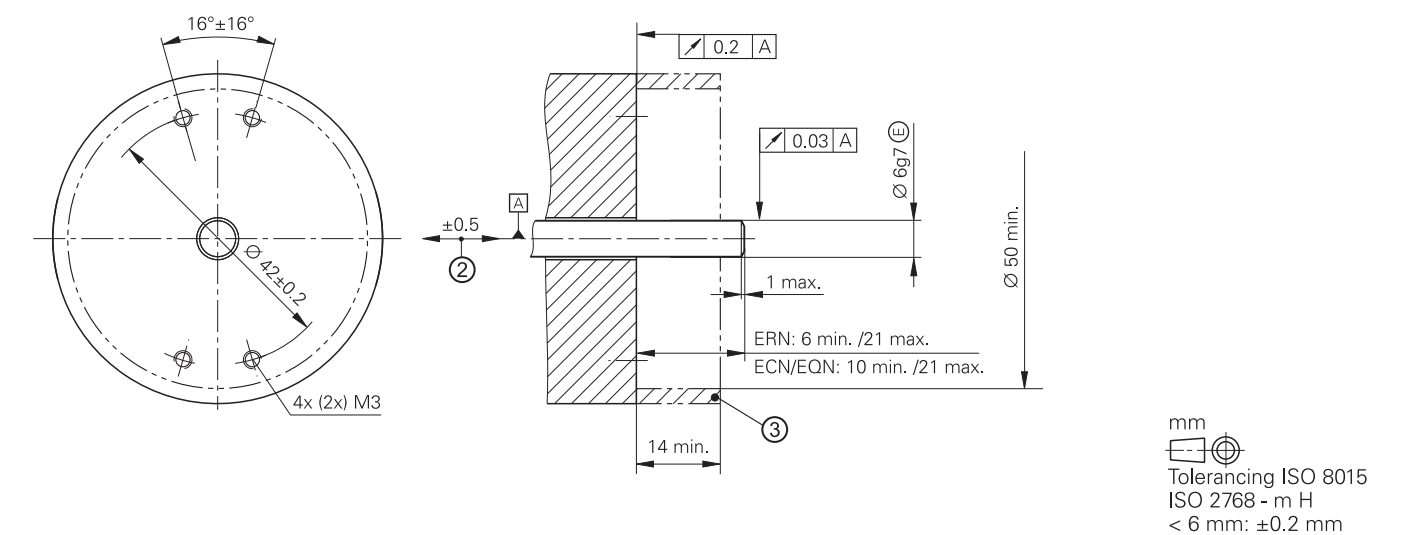

* = Ø 3.7 mm for encoders with the DRIVE-CLiQ interface

⊠ = Bearing of mating shaft

⊙ = Measuring point for operating temperature

⊕ = Reference mark position ±20°

1 = Two screws in clamping ring; tightening torque: 0.6 Nm ±0.1 Nm; width A/F: 1.5

2 = Compensation of mounting tolerances and thermal expansion; no dynamic motion permitted

3 = Ensure protection against contact (EN 60529)

4 = Direction of shaft rotation for output signals as per the interface description



	Incremental			
	ERN 1020	ERN 1030	ERN 1080	ERN 1070
Interface	□ TTL	□ HTLs	~ 1 V _{PP} ¹⁾	□ TTL
Line counts*	100 1000	200 1024	250 360 400 500 720 900 2048 2500 3600	1000 2500 3600
Reference mark	One			
Integrated interpolation*	-		5-fold	10-fold
Cutoff frequency -3 dB	-	-	≥ 180 kHz	-
Scanning frequency	≤ 300 kHz	≤ 160 kHz	-	≤ 100 kHz
Edge separation a	≥ 0.39 μs	≥ 0.76 μs	-	≥ 0.47 μs
System accuracy	1/20 of grating period			
Electrical connection*	Cable (1 m/5 m) with or without M23 coupling			Cable (5 m), free cable end
Supply voltage	DC 5 V ±0.5 V	DC 10 V to 30 V	DC 5 V ±0.5 V	DC 5 V ±0.25 V
Current consumption without load	≤ 120 mA	≤ 150 mA	≤ 120 mA	≤ 155 mA
Shaft	Blind hollow shaft Ø 6 mm			
Mech. permiss. shaft speed n	≤ 12000 rpm			
Starting torque (typical)	0.001 Nm (at 20 °C)			
Moment of inertia of rotor	≤ 0.5 · 10 ⁻⁶ kgm ²			
Permissible axial motion of measured shaft	±0.5 mm			
Vibration 55 Hz to 2000 Hz	≤ 100 m/s ² (EN 60068-2-6)			
Shock 6 ms	≤ 1000 m/s ² (EN 60068-2-27)			
Max. operating temp. ²⁾	100 °C	70 °C	100 °C	70 °C
Min. operating temp.	Fixed cable: -30 °C; moving cable: -10 °C			
Protection EN 60529	IP64			
Mass	≈ 0.1 kg			
Valid for ID	534909-xx	534911-xx	534913-xx	534912-xx

Bold: This preferred version is available on short notice.

* Please select when ordering

1) Limited tolerances: signal amplitude: 0.8 V_{PP} to 1.2 V_{PP}

2) For the relationship of operating temperature to shaft speed and supply voltage, see *General mechanical information*

	Absolute					
	Singleturn			Multiturn		
	ECN 1023	ECN 1013	ECN 1023 S	EQN 1035	EQN 1025	EQN 1035 S
Interface*	EnDat 2.2	EnDat 2.2	DRIVE-CLiQ	EnDat 2.2	EnDat 2.2	DRIVE-CLiQ
Ordering designation	EnDat22	EnDat01	DQ01	EnDat22	EnDat01	DQ01
Firmware ¹⁾	–	–	01.32.26.53			01.32.26.53
Positions per revolution	8388608 (23 bits)	8192 (13 bits)	8388608 (23 bits)	8388608 (23 bits)	8192 (13 bits)	8388608 (23 bits)
Revolutions	–			4096 (12 bits)		
Code	Pure binary		Pure binary	Pure binary		Pure binary
Elec. perm. shaft speed Deviations ^{2) 5)}	≤ 12000 rpm for continuous position value	≤ 4000 rpm/ ≤ 12000 rpm ±1 LSB/±16 LSB	≤ 12000 rpm for continuous position value	≤ 12000 rpm for continuous position value	≤ 4000 rpm/ ≤ 12000 rpm ±1 LSB/±16 LSB	≤ 12000 rpm for continuous position value
Calculation time t_{cal} Clock frequency	≤ 7 μs ≤ 8 MHz	≤ 9 μs ≤ 2 MHz	≤ 8 μs ³⁾	≤ 7 μs ≤ 8 MHz	≤ 9 μs ≤ 2 MHz	≤ 8 μs ³⁾
Incremental signals	–	~ 1 V _{PP} ⁴⁾	–	–	~ 1 V _{PP} ⁴⁾	–
Line count	–	512	–	–	512	–
Cutoff frequency –3 dB	–	≥ 190 kHz	–	–	≥ 190 kHz	–
System accuracy	±60''					
Electrical connection	Cable (1 m) with M12 coupling	Cable (1 m) with M23 coupling	Cable (1 m) with M12 coupling	Cable (1 m) with M12 coupling	Cable (1 m) with M23 coupling	Cable (1 m) with M12 coupling
Supply voltage	DC 3.6 V to 14 V		DC 10 V to 28.8 V	DC 3.6 V to 14 V		DC 10 V to 28.8 V
Power consumption (max.)	3.6 V: ≤ 0.6 W 14 V: ≤ 0.7 W		10 V: ≤ 850 mW 28.8 V: ≤ 900 mW	3.6 V: ≤ 0.7 W 14 V: ≤ 0.8 W		10 V: ≤ 950 mW 28.8 V: ≤ 1000 mW
Current consumption (typical, without load)	5 V: 85 mA		24 V: 32 mA	5 V: 105 mA		24 V: 35 mA
Shaft	Blind hollow shaft Ø 6 mm					
Mech. perm. shaft speed n	12000 rpm					
Starting torque (typical)	0.001 Nm (at 20 °C)			0.002 Nm (at 20 °C)		
Moment of inertia of rotor	≈ 0.5 · 10 ⁻⁶ kgm ²					
Permiss. axial motion of measured shaft	±0.5 mm					
Vibration 55 Hz to 2000 Hz Shock 6 ms	≤ 100 m/s ² (EN 60068-2-6) ≤ 1000 m/s ² (EN 60068-2-27)					
Max. operating temp.	100 °C		95 °C	100 °C		95 °C
Min. operating temp.	Fixed cable: –30 °C; moving cable: –10 °C					
Protection EN 60529	IP64					
Mass	≈ 0.1 kg					
Valid for ID	606683-xx	606681-xx	1211019-xx	606688-xx	606686-xx	1211020-xx

* Please select when ordering

¹⁾ SINAMICS/SIMOTION: ≥ V4.4 HF4; SINUMERIK without safety ≥ V4.4 SP1 HF3 (as per document: "Certified encoders with DRIVE-CLiQ Dependencies on SIMOTION / SINUMERIK and SINAMICS Hardware and Software versions" (version: 12/2018))

²⁾ Speed-dependent deviations between absolute and incremental signals

³⁾ Calculation time TIME_MAX_ACTVAL

⁴⁾ Limited tolerances: signal amplitude: 0.8 V_{PP} to 1.2 V_{PP}

⁵⁾ In the case of DRIVE-CLiQ interface: with ≥ 2 position requests per revolution

ECN/EQN/ERN 400 series

Absolute and incremental rotary encoders

- Stator coupling for plane surface
- Blind hollow shaft or hollow through shaft



Blind hollow shaft

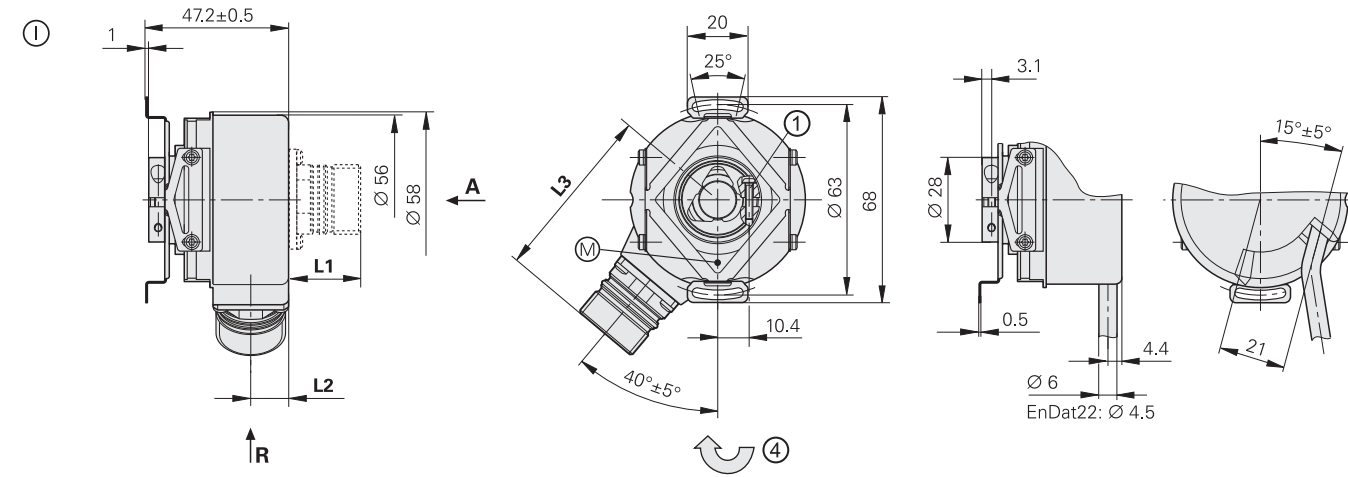

Hollow through shaft

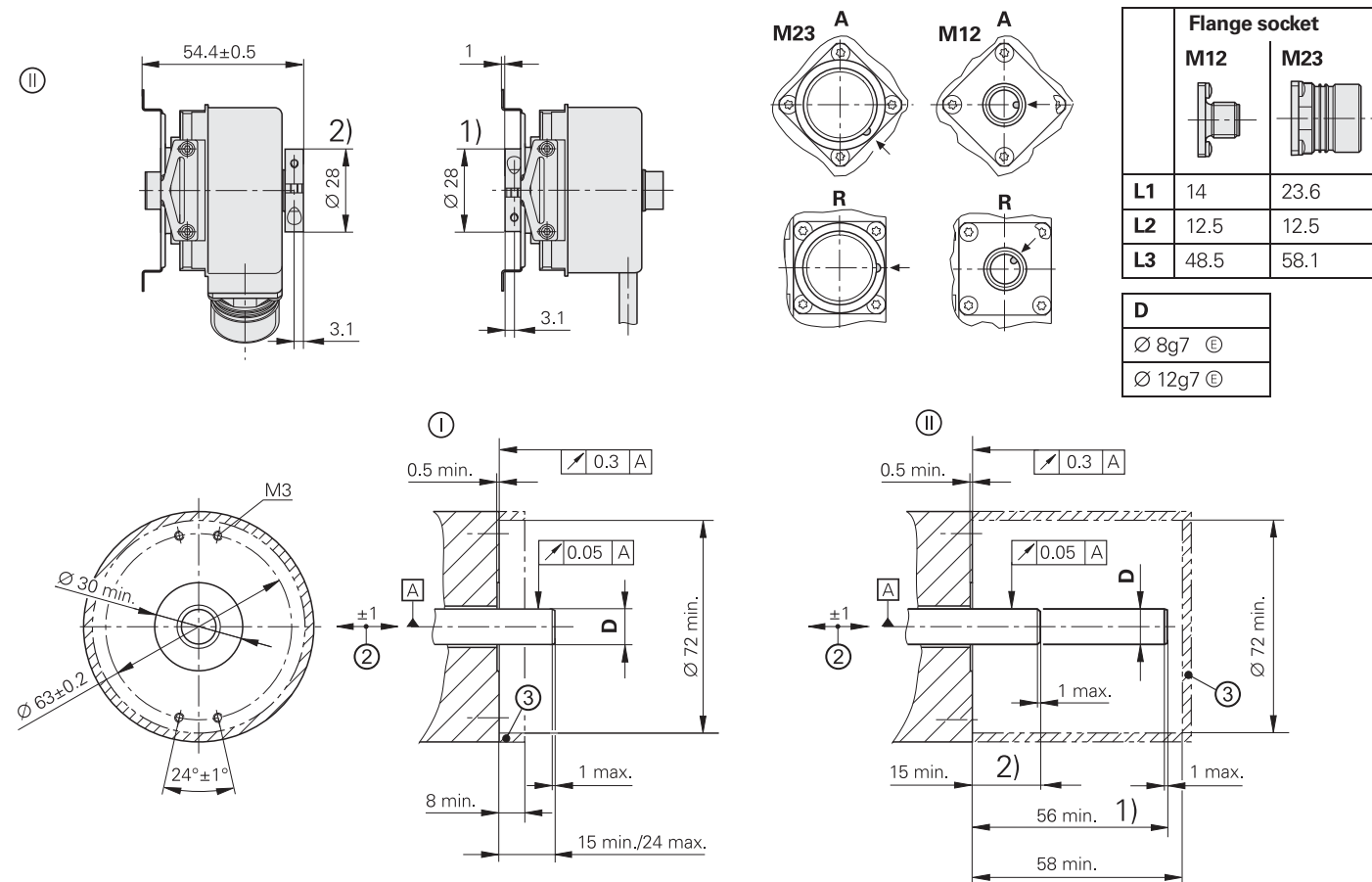

mm
 Tolerancing ISO 8015
 ISO 2768 - m H
 < 6 mm: ±0.2 mm

- Radial cable (can also be used axially)
- Ⓐ = Bearing of mating shaft
- Ⓞ = Measuring point for operating temperature
- 1 = Clamping screw with X8 hexalobular socket
- 2 = Compensation of mounting tolerances and thermal expansion; no dynamic motion permitted
- 3 = Ensure protection against contact (EN 60529)
- 4 = Direction of shaft rotation for output signals as per the interface description
- 1) = Clamping ring on housing side (delivery condition)
- 2) = Clamping ring on coupling side (optionally mountable)

	Incremental			
	ERN 420	ERN 460	ERN 430	ERN 480
Interface	□ TTL		□ HTL	~ 1 V _{PP} ¹⁾
Line counts*	250 500	1000 1024 1250 2000 2048 2500 3600 4096 5000		-
Reference mark	One			
Cutoff frequency -3 dB	-			≥ 180 kHz
Output frequency	≤ 300 kHz			-
Edge separation a	≥ 0.39 μs			-
System accuracy	1/20 of grating period			
Electrical connection*	<ul style="list-style-type: none"> • M23 flange socket, radial and axial (with blind hollow shaft) • Cable (1 m), free cable end 			
Supply voltage	DC 5 V ±0.5 V	DC 10 V to 30 V	DC 10 V to 30 V	DC 5 V ±0.5 V
Current consumption without load	≤ 120 mA	≤ 100 mA	≤ 150 mA	≤ 120 mA
Shaft*	Blind hollow shaft or hollow through shaft; Ø 8 mm or Ø 12 mm			
Mech. permitt. shaft speed n ²⁾	≤ 6000 rpm/≤ 12000 rpm ³⁾			
Starting torque (typical) at 20 °C	Blind hollow shaft: 0.01 Nm Hollow through shaft: 0.025 Nm (with IP66: 0.075 Nm)			
Moment of inertia of rotor	≤ 4.3 · 10 ⁻⁶ kgm ²			
Permissible axial motion of measured shaft	±1 mm			
Vibration 55 Hz to 2000 Hz	≤ 300 m/s ² ; flange socket version: 150 m/s ² (EN 60068-2-6); higher values upon request			
Shock 6 ms	≤ 2000 m/s ² (EN 60068-2-27)			
Max. operating temp. ²⁾	100 °C	70 °C	100 °C ⁴⁾	
Min. operating temp.	Flange socket or fixed cable: -40 °C; moving cable: -10 °C			
Protection EN 60529	At housing: IP67 (IP66 with hollow through shaft) At shaft inlet: IP64 (when Ø 12 mm, IP66 possible upon request)			
Mass	≈ 0.3 kg			
Valid for ID	385420-xx	385460-xx	385430-xx	385480-xx ⁵⁾

Bold: This preferred version is available on short notice.

* Please select when ordering



1) Limited tolerances: signal amplitude: 0.8 V_{PP} to 1.2 V_{PP}

2) For the relationship of operating temperature to shaft speed and supply voltage, see *General mechanical information*

3) With two shaft clampings (only with hollow through shaft)

4) 80 °C for ERN 480 with 4096 or 5000 lines

5) Available with mechanical fault exclusion; for deviating specifications and special mounting information, see the *Fault Exclusion* Customer Information document

	Absolute			Multiturn		
	Singleturn ECN 425 	ECN 413	SSI	EQN 437 	EQN 425	SSI
Interface*	EnDat 2.2	EnDat 2.2	SSI	EnDat 2.2	EnDat 2.2	SSI
Ordering designation	EnDat22	EnDat01	SSI39r1	EnDat22	EnDat01	SSI41r1
Positions per revolution	33554432 (25 bits)	8192 (13 bits)		33554432 (25 bits)	8192 (13 bits)	
Revolutions	–			4096		
Code	Pure binary		Gray	Pure binary		Gray
Elec. permiss. shaft speed Deviations ¹⁾	≤ 12000 rpm for continuous position value	<i>512 lines:</i> ≤ 5000/12000 rpm ±1 LSB/±100 LSB <i>2048 lines:</i> ≤ 1500/12000 rpm ±1 LSB/±50 LSB	≤ 12000 rpm ±12 LSB	≤ 12000 rpm for continuous position value	<i>512 lines:</i> ≤ 5000/10000 rpm ±1 LSB/±100 LSB <i>2048 lines:</i> ≤ 1500/10000 rpm ±1 LSB/±50 LSB	≤ 12000 rpm ±12 LSB
Calculation time t_{cal} Clock frequency	≤ 7 μs ≤ 8 MHz	≤ 9 μs ≤ 2 MHz	≤ 5 μs –	≤ 7 μs ≤ 8 MHz	≤ 9 μs ≤ 2 MHz	≤ 5 μs –
Incremental signals	Without	$\sim 1 V_{PP}^{2)}$		Without	$\sim 1 V_{PP}^{2)}$	
Line counts*	–	512 2048	512	–	512 2048	512
Cutoff frequency –3 dB Output frequency	– –	<i>512 lines:</i> ≥ 130 kHz; <i>2048 lines:</i> ≥ 400 kHz –		– –	<i>512 lines:</i> ≥ 130 kHz; <i>2048 lines:</i> ≥ 400 kHz –	
System accuracy	±20"	<i>512 lines:</i> ±60"; <i>2048 lines:</i> ±20"		±20"	<i>512 lines:</i> ±60"; <i>2048 lines:</i> ±20"	
Electrical connection*	<ul style="list-style-type: none"> • M12 flange socket, radial • Cable (1 m) with M12 coupling 	<ul style="list-style-type: none"> • M23 flange socket, radial • Cable (1 m) with M23 coupling or free cable end 		<ul style="list-style-type: none"> • M12 flange socket, radial • Cable (1 m) with M12 coupling 	<ul style="list-style-type: none"> • M23 flange socket, radial • Cable (1 m) with M23 coupling or free cable end 	
Supply voltage	DC 3.6 V to 14 V		DC 4.75 V to 30 V	DC 3.6 V to 14 V		DC 4.75 V to 30 V
Power consumption (max.)	3.6 V: ≤ 0.6 W 14 V: ≤ 0.7 W		5 V: ≤ 0.8 W 10 V: ≤ 0.65 W 30 V: ≤ 1 W	3.6 V: ≤ 0.7 W 14 V: ≤ 0.8 W		5 V: ≤ 0.95 W 10 V: ≤ 0.75 W 30 V: ≤ 1.1 W
Current consumption (typical, without load)	5 V: 85 mA		5 V: 90 mA 24 V: 24 mA	5 V: 105 mA		5 V: 120 mA 24 V: 28 mA
Shaft*	Blind hollow shaft or hollow through shaft; Ø 8 mm or Ø 12 mm					
Mech. permiss. shaft speed $n^{3)}$	≤ 6000 rpm/≤ 12000 rpm ⁴⁾					
Starting torque (typical) at 20 °C	<i>Blind hollow shaft:</i> 0.01 Nm; <i>hollow through shaft:</i> 0.025 Nm (with IP66: 0.075 Nm)					
Moment of inertia of rotor	≤ 4.3 · 10 ⁻⁶ kgm ²					
Permissible axial motion of measured shaft	±1 mm					
Vibration 55 Hz to 2000 Hz Shock 6 ms	≤ 300 m/s ² ; <i>flange socket version:</i> ≤ 150 m/s ² (EN 60068-2-6); higher values upon request ≤ 2000 m/s ² (EN 60068-2-27)					
Max. operating temp. ³⁾	100 °C					
Min. operating temp.	<i>Flange socket or fixed cable:</i> –40 °C; <i>moving cable:</i> –10 °C					
Protection EN 60529	<i>At housing:</i> IP67 (IP66 with hollow through shaft) <i>At shaft inlet:</i> IP64 (when Ø 12 mm, IP66 possible upon request)					
Mass	≈ 0.3 kg					
Valid for ID	683644-xx ⁵⁾ / 1178024-xx ^{5) 6)}	1065932-xx	1132405-xx / 1353129-xx ⁶⁾	683646-xx ⁵⁾ / 1178025-xx ^{5) 6)}	1109258-xx	1132407-xx / 1353131-xx ⁶⁾

Bold: This preferred version is available on short notice.

* Please select when ordering

¹⁾ Speed-dependent deviations between absolute value and incremental signal

²⁾ Limited tolerances: signal amplitude: 0.8 V_{PP} to 1.2 V_{PP}

³⁾ For the relationship of operating temperature to shaft speed and supply voltage, see *General mechanical information*

⁴⁾ With two shaft clampings (only with hollow through shaft)

⁵⁾ Also available with functional safety; for dimensions and specifications, see Product Information document

⁶⁾ Successor variants

EQN 425

Rotary encoder for absolute position values with blind hollow shaft

- Stator coupling for plane surface
- EnDat interface
- Additional incremental signals with TTL or HTL levels

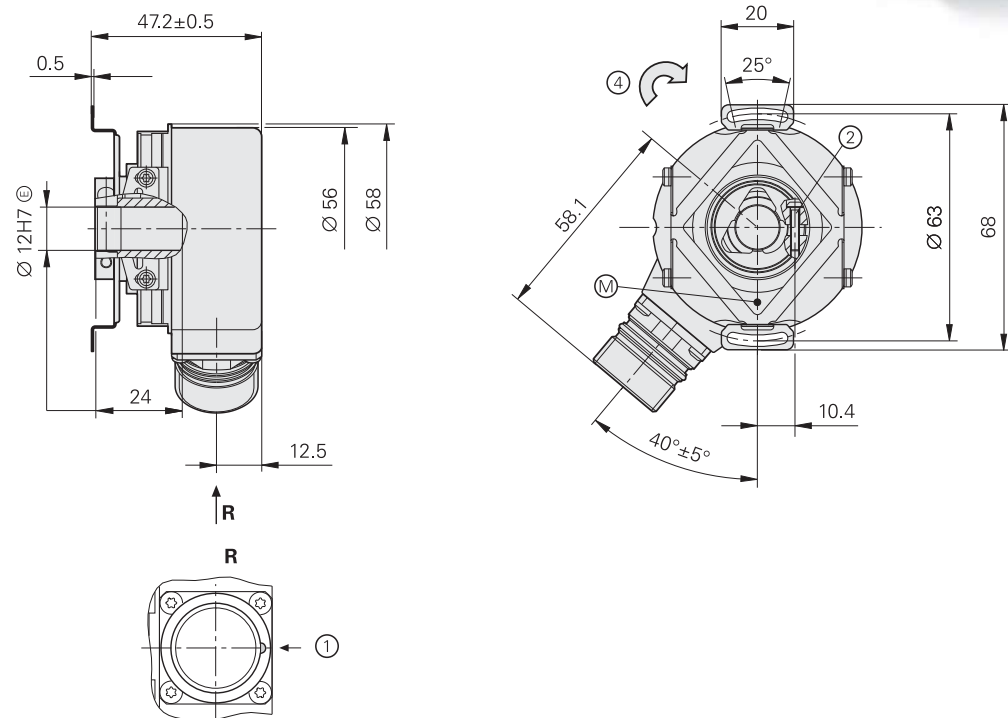

Required mating dimensions

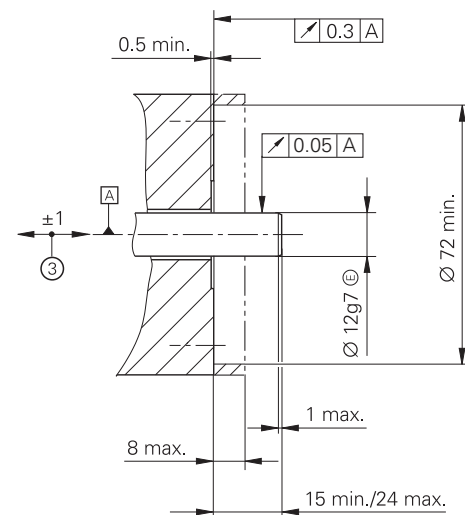
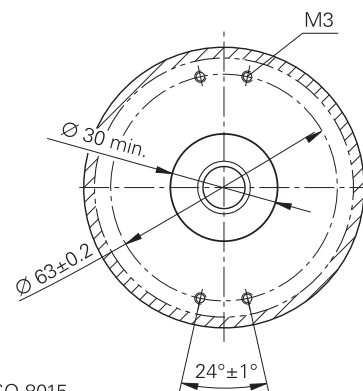

mm
Tolerancing ISO 8015
ISO 2768 - m H
< 6 mm: ±0.2 mm

- ⊠ = Bearing of mating shaft
- ⊙ = Measuring point for operating temperature
- 1 = Connector coding
- 2 = Clamping screw with X8 hexalobular socket; tightening torque: 1.1 Nm ±0.1 Nm
- 3 = Compensation of mounting tolerances and thermal expansion; no dynamic motion permitted
- 4 = Direction of shaft rotation for output signals as per the interface description

	Absolute EQN 425 – Multiturn					
Interface	EnDat 2.2					
Ordering designation*	EnDatH			EnDatT		
Positions per revolution	8192 (13 bits)					
Revolutions	4096 (12 bits)					
Code	Pure binary					
Calculation time t_{cal} Clock frequency	≤ 9 μs ≤ 2 MHz					
Incremental signals	HTL			TTL		
Signal periods *	512	1024	2048	512	2048	4096
Edge separation a	≥ 2.4 μs	≥ 0.8 μs	≥ 0.6 μs	≥ 2.4 μs	≥ 0.6 μs	≥ 0.2 μs
Output frequency	≤ 52 kHz	≤ 103 kHz	≤ 205 kHz	≤ 52 kHz	≤ 205 kHz	≤ 410 kHz
System accuracy ¹⁾	±60"	±60"	±20"	±60"	±20"	±20"
Electrical connection	17-pin M23 radial flange socket (male)					
Cable length ²⁾	≤ 100 m (with HEIDENHAIN cable)					
Supply voltage	DC 10 V to 30 V			DC 4.75 V to 30 V		
Power consumption (max.) ³⁾	See Power consumption diagram			At 4.75 V: ≤ 900 mW At 30 V: ≤ 1100 mW		
Current consumption (typical, without load)	At 10 V: ≤ 56 mA At 24 V: ≤ 34 mA			At 5 V: ≤ 100 mA At 24 V: ≤ 25 mA		
Shaft	Blind hollow shaft Ø 12 mm					
Mech. permiss. shaft speed $n^4)$	≤ 6000 rpm					
Starting torque (typical)	0.01 Nm (at 20 °C)					
Moment of inertia of rotor	$4.3 \cdot 10^{-6} \text{ kgm}^2$					
Permissible axial motion of measured shaft	≤ ±1 mm					
Vibration 10 Hz to 2000 Hz ⁵⁾ Shock 6 ms	≤ 150 m/s ² (EN 60068-2-6) ≤ 2000 m/s ² (EN 60068-2-27)					
Max. operating temp. ⁴⁾	100 °C					
Min. operating temp. ⁴⁾	-40 °C					
Protection EN 60529	Housing: IP67 Shaft exit: IP64					
Mass	≈ 0.30 kg					
Valid for ID	1042545-xx			1042540-xx		

* Please select when ordering

1) For absolute position value; accuracy of the incremental signal upon request

2) For HTL signals, the maximum cable length depends on the output frequency (see the Cable length for HTL diagrams)

3) See General electrical information in the Interfaces of HEIDENHAIN Encoders brochure

4) For the relationship of operating temperature to shaft speed and supply voltage, see General mechanical information

5) 10 Hz to 55 Hz constant over 4.9 mm peak to peak

EQN 425

Rotary encoder for absolute position values with blind hollow shaft

- Stator coupling for plane surface
- SSI interface
- Additional incremental signals with TTL or HTL levels

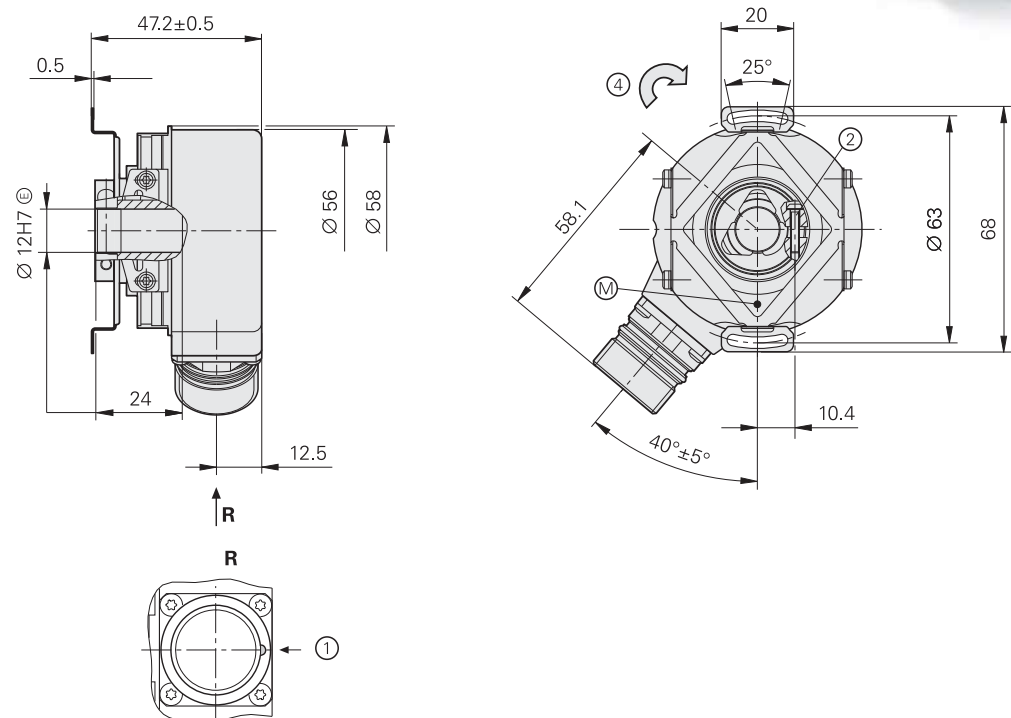

Required mating dimensions

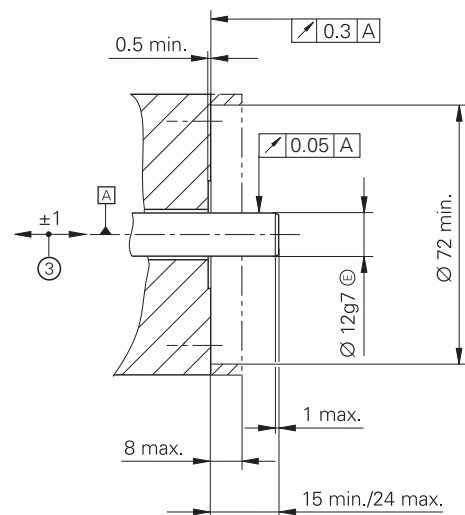
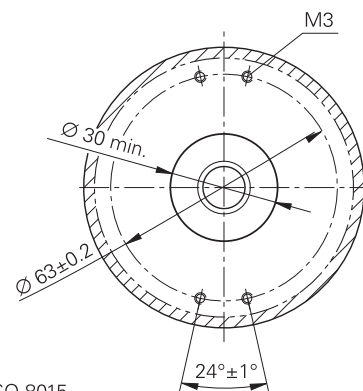

mm

 Tolerancing ISO 8015
 ISO 2768 - m H
 < 6 mm: ±0.2 mm

- ⊠ = Bearing of mating shaft
- ⊙ = Measuring point for operating temperature
- 1 = Connector coding
- 2 = Clamping screw with X8 hexalobular socket; tightening torque: 1.1 Nm ±0.1 Nm
- 3 = Compensation of mounting tolerances and thermal expansion; no dynamic motion permitted
- 4 = Direction of shaft rotation for output signals as per the interface description

		Absolute					
		EQN 425 – Multiturn					
Interface	SSI						
Ordering designation*	SSI41H					SSI41T	
Positions per revolution	8192 (13 bits)						
Revolutions	4096 (12 bits)						
Code	Gray						
Calculation time t_{cal}	≤ 5 μs						
Clock frequency	≤ 1 MHz						
Incremental signals	HTL ⁶⁾			TTL			
Signal periods *	512	1024	2048	512	2048	4096	
Edge separation a	≥ 2.4 μs	≥ 0.8 μs	≥ 0.6 μs	≥ 2.4 μs	≥ 0.6 μs	≥ 0.2 μs	
Output frequency	≤ 52 kHz	≤ 103 kHz	≤ 205 kHz	≤ 52 kHz	≤ 205 kHz	≤ 410 kHz	
System accuracy¹⁾	±60"	±60"	±20"	±60"	±20"	±20"	
Electrical connection	12-pin M23 radial flange socket (male)			17-pin M23 radial flange socket (male)			
Cable length ²⁾	≤ 100 m (with HEIDENHAIN cable)						
Supply voltage	DC 10 V to 30 V			DC 4.75 V to 30 V			
Power consumption (max.) ³⁾	See <i>Power consumption diagram</i>			At 4.75 V: ≤ 900 mW At 30 V: ≤ 1100 mW			
Current consumption (typical, without load)	At 10 V: ≤ 56 mA At 24 V: ≤ 34 mA			At 5 V: ≤ 100 mA At 24 V: ≤ 25 mA			
Shaft	Blind hollow shaft Ø 12 mm						
Mech. permiss. shaft speed $n^4)$	≤ 6000 rpm						
Starting torque (typical)	0.01 Nm (at 20 °C)						
Moment of inertia of rotor	4.3 · 10 ⁻⁶ kgm ²						
Permissible axial motion of measured shaft	≤ ±1 mm						
Vibration 10 Hz to 2000 Hz ⁵⁾	≤ 150 m/s ² (EN 60068-2-6)						
Shock 6 ms	≤ 2000 m/s ² (EN 60068-2-27)						
Max. operating temp. ⁴⁾	100 °C						
Min. operating temp. ⁴⁾	-40 °C						
Protection EN 60529	Housing: IP67 Shaft exit: IP64						
Mass	≈ 0.30 kg						
Valid for ID	1065029-xx			1042533-xx			

- * Please select when ordering
- 1) For absolute position value; accuracy of the incremental signal upon request
- 2) For HTL signals, the maximum cable length depends on the output frequency (see the *Cable length for HTL diagrams*)
- 3) See *General electrical information* in the *Interfaces of HEIDENHAIN Encoders* brochure
- 4) For the relationship of operating temperature to shaft speed and supply voltage, see *General mechanical information*
- 5) 10 Hz to 55 Hz constant over 4.9 mm peak to peak
- 6) HTLs upon request

ECN/EQN 400F/S series

Absolute rotary encoders

- Stator coupling for plane surface
- Blind hollow shaft or hollow through shaft
- Fanuc Serial Interface or Siemens DRIVE-CLiQ interface



Blind hollow shaft

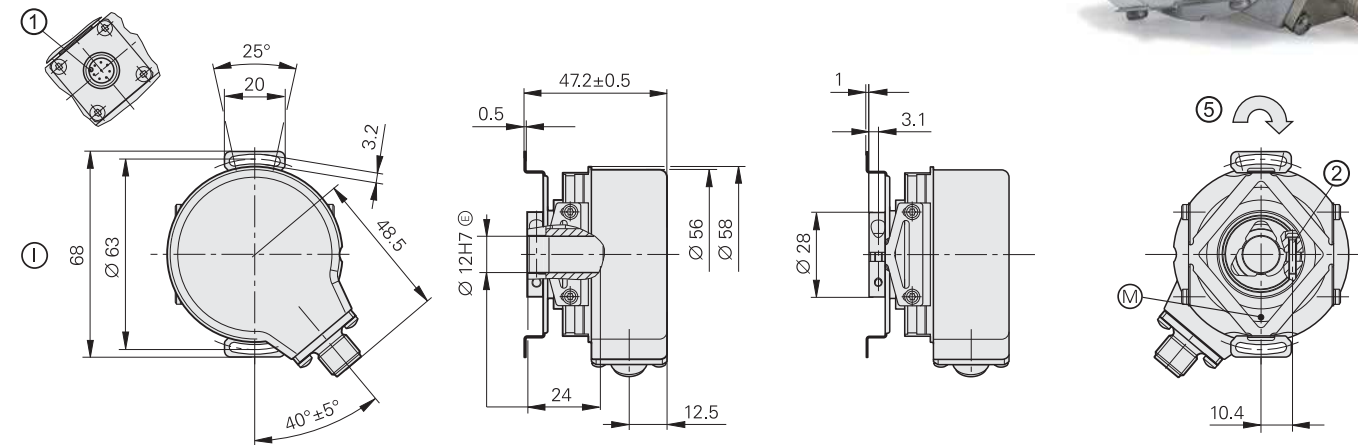

Hollow through shaft

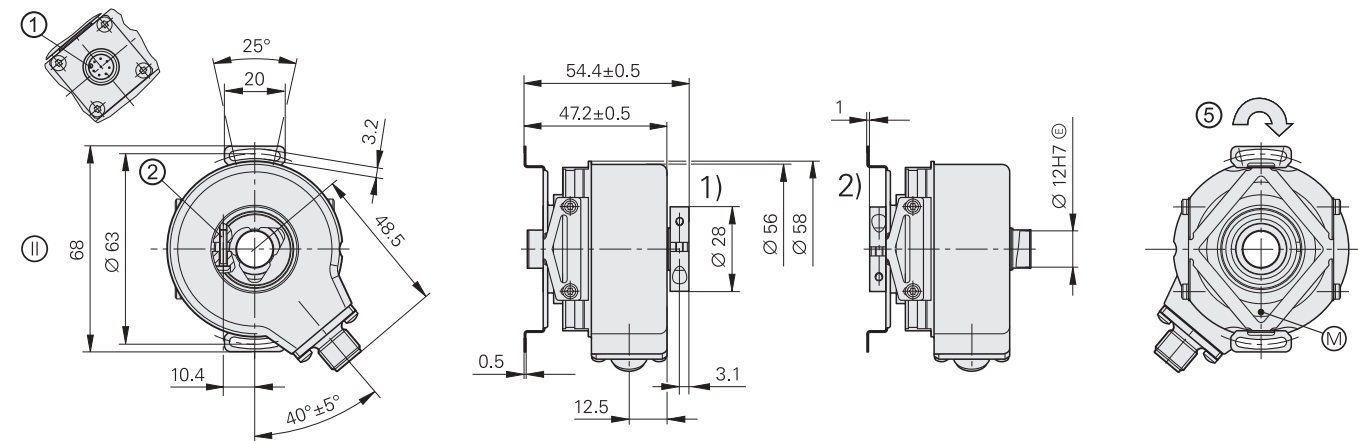

Required mating dimensions

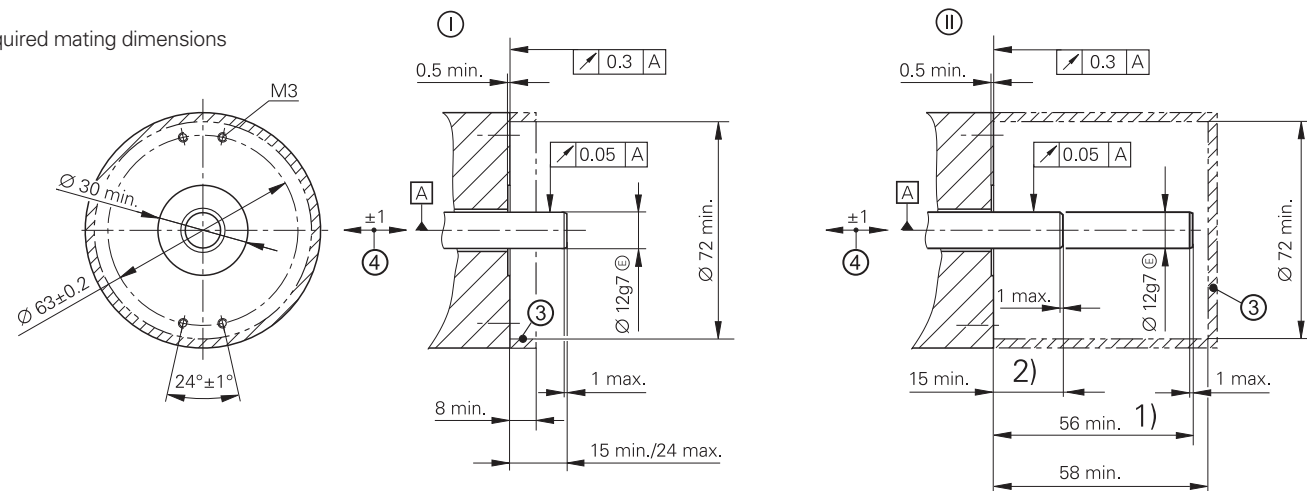

mm

 Tolerancing ISO 8015
 ISO 2768 - m H
 < 6 mm: ±0.2 mm

- ▭ = Bearing of mating shaft
- Ⓜ = Measuring point for operating temperature
- 1 = Connector coding
- 2 = Clamping screw with X8 hexalobular socket; tightening torque: 1.1 Nm ±0.1 Nm
- 3 = Ensure protection against contact (EN 60529)
- 4 = Compensation of mounting tolerances and thermal expansion; no dynamic motion permitted
- 5 = Direction of shaft rotation for output signals as per the interface description
- 1) = Clamping ring on housing side (delivery condition)
- 2) = Clamping ring on coupling side (optionally mountable)

DRIVE-CLiQ is a registered trademark of Siemens AG.

	Absolute		Multiturn	
	Singleturn ECN 425F	ECN 424S	EQN 437F	EQN 436S
Interface	Fanuc Serial Interface; αi Interface	DRIVE-CLiQ	Fanuc Serial Interface; αi Interface	DRIVE-CLiQ
Ordering designation	Fanuc05 ¹⁾	DQ01	Fanuc06 ¹⁾	DQ01
Positions per revolution	αi: 33554432 (25 bits) α: 8388608 (23 bits)	16777216 (24 bits)	33554432 (25 bits)	16777216 (24 bits)
Revolutions	8192 via revolution counter	–	αi: 4096	4096
Code	Pure binary			
Elec. perm. shaft speed	≤ 15000 rpm for continuous position value			
Calculation time t _{cal}	≤ 5 μs	≤ 8 μs ²⁾	≤ 5 μs	≤ 8 μs ²⁾
System accuracy	±20"			
Electrical connection	M12 flange socket, radial			
Cable length	≤ 30 m	≤ 95 m ³⁾	≤ 30 m	≤ 95 m ³⁾
DC supply voltage	3.6 V to 14 V	10 V to 36 V	3.6 V to 14 V	10 V to 36 V
Power consumption (max.)	5 V: ≤ 0.7 W 14 V: ≤ 0.8 W	10 V: ≤ 1.4 W 36 V: ≤ 1.5 W	5 V: ≤ 0.75 W 14 V: ≤ 0.85 W	10 V: ≤ 1.4 W 36 V: ≤ 1.5 W
Current consumption (typical, without load)	5 V: 90 mA	24 V: 37 mA	5 V: 100 mA	24 V: 43 mA
Shaft*	Blind hollow shaft or hollow through shaft Ø 12 mm; with DRIVE-CLiQ, also available with blind hollow shaft Ø 10 mm			
Mech. perm. shaft speed n ⁴⁾	≤ 6000 rpm/≤ 12000 rpm ⁵⁾			
Starting torque (typical) at 20 °C	Blind hollow shaft: 0.01 Nm Hollow through shaft: 0.025 Nm (with IP66: 0.075 Nm)			
Moment of inertia of rotor	≤ 4.6 · 10 ⁻⁶ kgm ²			
Permissible axial motion of measured shaft	±1 mm			
Vibration 55 Hz to 2000 Hz Shock 6 ms	≤ 150 m/s ² (EN 60068-2-6) ≤ 2000 m/s ² (EN 60068-2-27)			
Max. operating temp. ⁴⁾	100 °C			
Min. operating temp.	-30 °C			
Protection EN 60529	At housing: IP67 (IP66 with hollow through shaft); at shaft inlet: IP64 (at DQ01 Ø 12 mm with blind hollow shaft, Fanuc06, Mit03-4, IP66 upon request)			
Mass	≈ 0.3 kg			
Valid for ID	1081302-xx	1036798-xx ⁶⁾	1081301-xx	1036801-xx ⁶⁾

- * Please select when ordering
- 1) Optimized for Fanuc machine tool controls
- 2) Calculation time TIME_MAX_ACTVAL
- 3) See the *Interfaces of HEIDENHAIN Encoders* brochure; with n_{EN} = 1 (including adapter cable)
- 4) For the relationship of operating temperature to shaft speed and supply voltage, see *General mechanical information*.
- 5) With two shaft clampings (only with hollow through shaft)
- 6) Also available with functional safety; for dimensions and specifications, see Product Information document

ECN/EQN/ERN 400 series

Absolute and incremental rotary encoders

- Stator coupling for universal mounting
- Blind hollow shaft or hollow through shaft

Blind hollow shaft

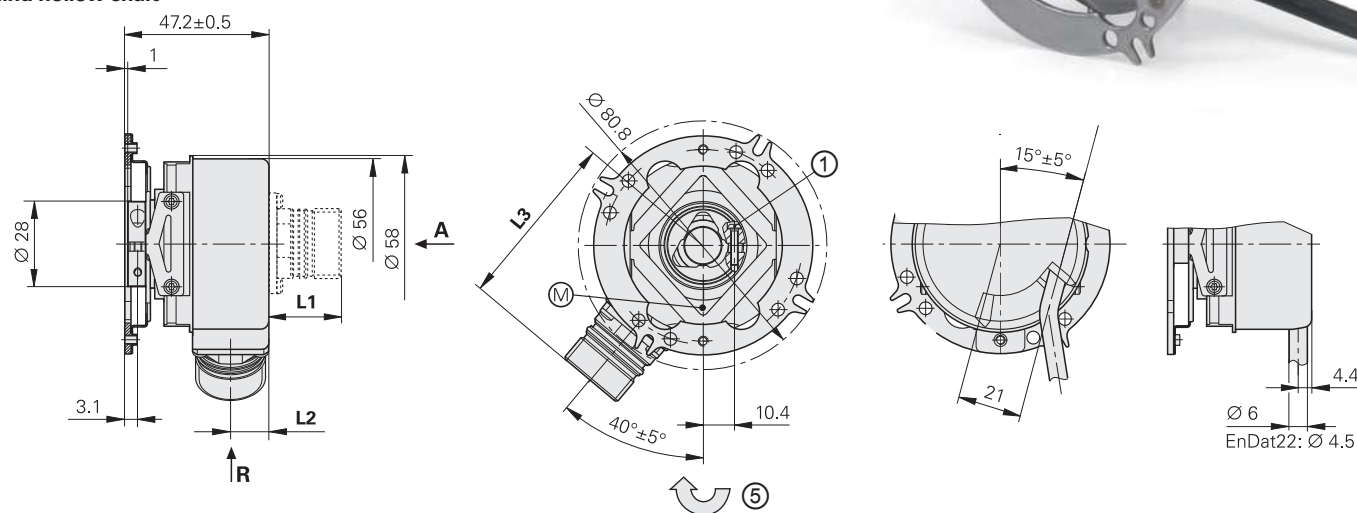

Hollow through shaft

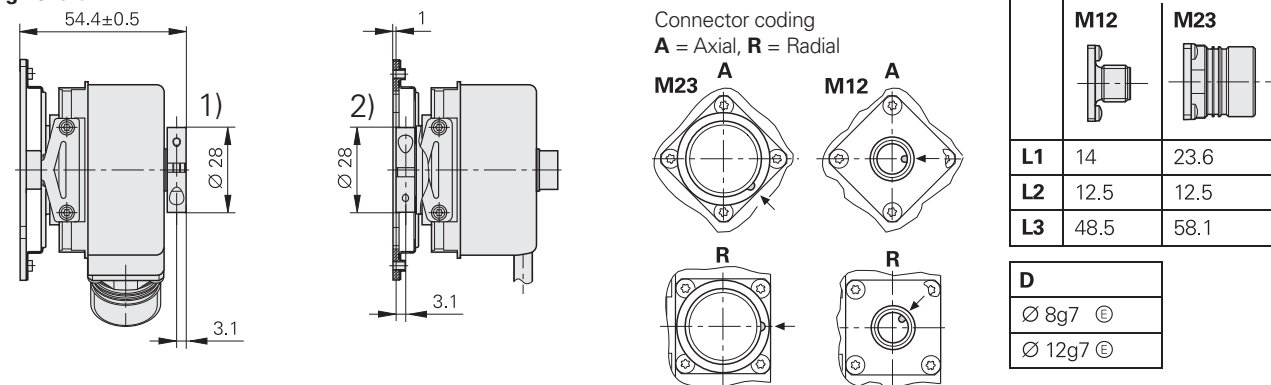

Required mating dimensions

Blind hollow shaft

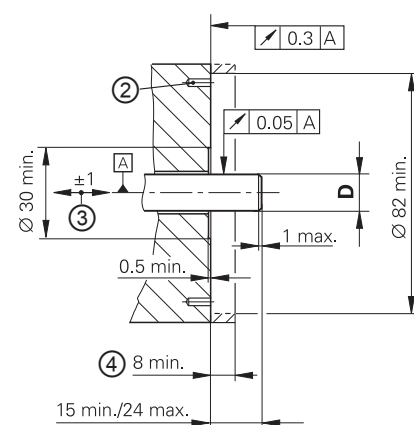

Hollow through shaft

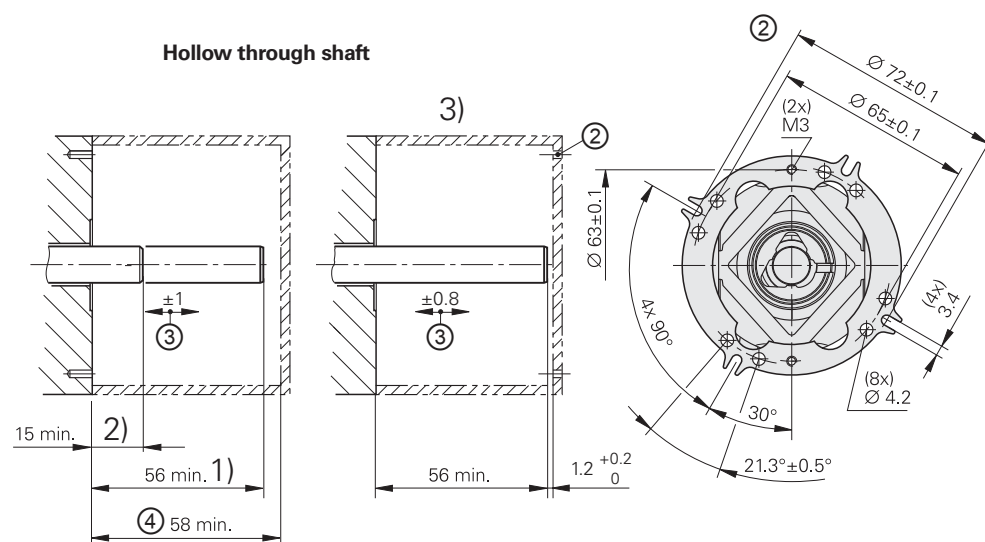

mm

Tolerancing ISO 8015
ISO 2768 - m H
< 6 mm: ±0.2 mm

Radial cable (can also be used axially)

- Ⓐ = Bearing of mating shaft
- Ⓜ = Measuring point for operating temperature
- 1 = Clamping screw with X8 hexalobular socket
- 2 = Hole pattern for fastening, see coupling
- 3 = Compensation of mounting tolerances and thermal expansion; no dynamic motion permitted
- 4 = Ensure protection against contact (EN 60529)
- 5 = Direction of shaft rotation for output signals as per the interface description
- 1) = Clamping ring on housing side (delivery condition)
- 2) = Clamping ring on coupling side (optionally mountable)

	Incremental			
	ERN 420	ERN 460	ERN 430	ERN 480
Interface	□ TTL		□ HTL	~ 1 V _{PP} ¹⁾
Line counts*	250 500	1000 1024 1250 2000 2048 2500 3600 4096 5000		-
Reference mark	One			
Cutoff frequency -3 dB	-			≥ 180 kHz
Output frequency	≤ 300 kHz			-
Edge separation a	≥ 0.39 μs			-
System accuracy	1/20 of grating period			
Electrical connection*	<ul style="list-style-type: none"> • M23 flange socket, radial and axial (with blind hollow shaft) • Cable (1 m), free cable end 			
Supply voltage	DC 5 V ±0.5 V	DC 10 V to 30 V	DC 10 V to 30 V	DC 5 V ±0.5 V
Current consumption without load	≤ 120 mA	≤ 100 mA	≤ 150 mA	≤ 120 mA
Shaft*	Blind hollow shaft or hollow through shaft; Ø 8 mm or Ø 12 mm			
Mech. perm. shaft speed n ²⁾	≤ 6000 rpm/≤ 12000 rpm ³⁾			
Starting torque (typical) at 20 °C	Blind hollow shaft: 0.01 Nm Hollow through shaft: 0.025 Nm (with IP66: 0.075 Nm)			
Moment of inertia of rotor	≤ 4.3 · 10 ⁻⁶ kgm ²			
Permissible axial motion of measured shaft	±1 mm			
Vibration 55 Hz to 2000 Hz	≤ 300 m/s ² ; flange socket version: 150 m/s ² (EN 60068-2-6); higher values upon request			
Shock 6 ms	≤ 2000 m/s ² (EN 60068-2-27)			
Max. operating temp. ²⁾	100 °C	70 °C	100 °C ⁴⁾	
Min. operating temp.	Flange socket or fixed cable: -40 °C; moving cable: -10 °C			
Protection EN 60529	At housing: IP67 (IP66 with hollow through shaft) At shaft inlet: IP64 (when Ø 12 mm, IP66 possible upon request)			
Mass	≈ 0.3 kg			
Valid for ID	385424-xx	385464-xx	385434-xx	385483-xx

Bold: This preferred version is available on short notice.

- * Please select when ordering
- 1) Limited tolerances: signal amplitude: 0.8 V_{PP} to 1.2 V_{PP}
- 2) For the relationship of operating temperature to shaft speed and supply voltage, see *General mechanical information*
- 3) With two shaft clampings (only with hollow through shaft)
- 4) 80 °C for ERN 480 with 4096 or 5000 lines

	Absolute			Multiturn		
	Singleturn ECN 425	ECN 413		EQN 437	EQN 425	
Interface*	EnDat 2.2	EnDat 2.2	SSI	EnDat 2.2	EnDat 2.2	SSI
Ordering designation	EnDat22	EnDat01	SSI39r1	EnDat22	EnDat01	SSI41r1
Positions per revolution	33554432 (25 bits)	8192 (13 bits)		33554432 (25 bits)	8192 (13 bits)	
Revolutions	–			4096		
Code	Pure binary		Gray	Pure binary		Gray
Elec. permiss. shaft speed Deviations ¹⁾	≤ 12000 rpm for continuous position value	<i>512 lines:</i> ≤ 5000/12000 rpm ±1 LSB/±100 LSB <i>2048 lines:</i> ≤ 1500/12000 rpm ±1 LSB/±50 LSB	≤ 12000 rpm ±12 LSB	≤ 12000 rpm for continuous position value	<i>512 lines:</i> ≤ 5000/10000 rpm ±1 LSB/±100 LSB <i>2048 lines:</i> ≤ 1500/10000 rpm ±1 LSB/±50 LSB	≤ 12000 rpm ±12 LSB
Calculation time t_{cal} Clock frequency	≤ 7 μs ≤ 8 MHz	≤ 9 μs ≤ 2 MHz	≤ 5 μs –	≤ 7 μs ≤ 8 MHz	≤ 9 μs ≤ 2 MHz	≤ 5 μs –
Incremental signals	Without	~ 1 V _{PP} ²⁾		Without	~ 1 V _{PP} ²⁾	
Line counts*	–	512 2048	512	–	512 2048	512
Cutoff frequency –3 dB Output frequency	– –	<i>512 lines:</i> ≥ 130 kHz; <i>2048 lines:</i> ≥ 400 kHz –		– –	<i>512 lines:</i> ≥ 130 kHz; <i>2048 lines:</i> ≥ 400 kHz –	
System accuracy	±20"	<i>512 lines:</i> ±60"; <i>2048 lines:</i> ±20"		±20"	<i>512 lines:</i> ±60"; <i>2048 lines:</i> ±20"	
Electrical connection*	• M12 flange socket , radial • Cable (1 m) with M12 coupling	• M23 flange socket , radial • Cable (1 m) with M23 coupling or free cable end		• M12 flange socket , radial • Cable (1 m) with M12 coupling	• M23 flange socket , radial • Cable (1 m) with M23 coupling or free cable end	
Supply voltage	DC 3.6 V to 14 V	DC 3.6 V to 14 V	DC 4.75 V to 30 V	DC 3.6 V to 14 V	DC 3.6 V to 14 V	DC 4.75 V to 30 V
Power consumption (max.)	3.6 V: ≤ 0.6 W 14 V: ≤ 0.7 W	5 V: ≤ 0.8 W 10 V: ≤ 0.65 W 30 V: ≤ 1 W		3.6 V: ≤ 0.7 W 14 V: ≤ 0.8 W	5 V: ≤ 0.95 W 10 V: ≤ 0.75 W 30 V: ≤ 1.1 W	
Current consumption (typical, without load)	5 V: 85 mA	5 V: 90 mA 24 V: 24 mA		5 V: 105 mA	5 V: 120 mA 24 V: 28 mA	
Shaft*	Blind hollow shaft or hollow through shaft; Ø 8 mm or Ø 12 mm					
Mech. permiss. shaft speed $n^3)$	≤ 6000 rpm/≤ 12000 rpm ⁴⁾					
Starting torque (typical) at 20 °C	<i>Blind hollow shaft:</i> 0.01 Nm <i>Hollow through shaft:</i> 0.025 Nm (with IP66: 0.075 Nm)					
Moment of inertia of rotor	≤ 4.3 · 10 ⁻⁶ kgm ²					
Permissible axial motion of measured shaft	±1 mm					
Vibration 55 Hz to 2000 Hz Shock 6 ms	≤ 300 m/s ² ; <i>flange socket version:</i> 150 m/s ² (EN 60068-2-6); higher values upon request ≤ 2000 m/s ² (EN 60068-2-27)					
Max. operating temp. ³⁾	100 °C					
Min. operating temp.	<i>Flange socket or fixed cable:</i> –40 °C; <i>moving cable:</i> –10 °C					
Protection EN 60529	<i>At housing:</i> IP67 (IP66 with hollow through shaft) <i>At shaft inlet:</i> IP64 (when Ø 12 mm, IP66 possible upon request)					
Mass	≈ 0.3 kg					
Valid for ID	683644-xx / 1178024-xx ⁵⁾	1065932-xx	1132405-xx / 1353129-xx ⁵⁾	683646-xx / 1178025-xx ⁵⁾	1109258-xx	1132407-xx / 1353131-xx ⁵⁾

Bold: This preferred version is available on short notice.

¹⁾ Speed-dependent deviations between absolute value and incremental signal

* Please select when ordering

²⁾ Limited tolerances: signal amplitude: 0.8 V_{PP} to 1.2 V_{PP}

³⁾ For the relationship of operating temperature to shaft speed and supply voltage, see *General mechanical information*

⁴⁾ With two shaft clampings (only with hollow through shaft)

⁵⁾ Successor variants

ECN/ERN 100 series

Absolute and incremental rotary encoders

- Stator coupling for plane surface
- Hollow through shaft



ERN 1x0/ECN 113

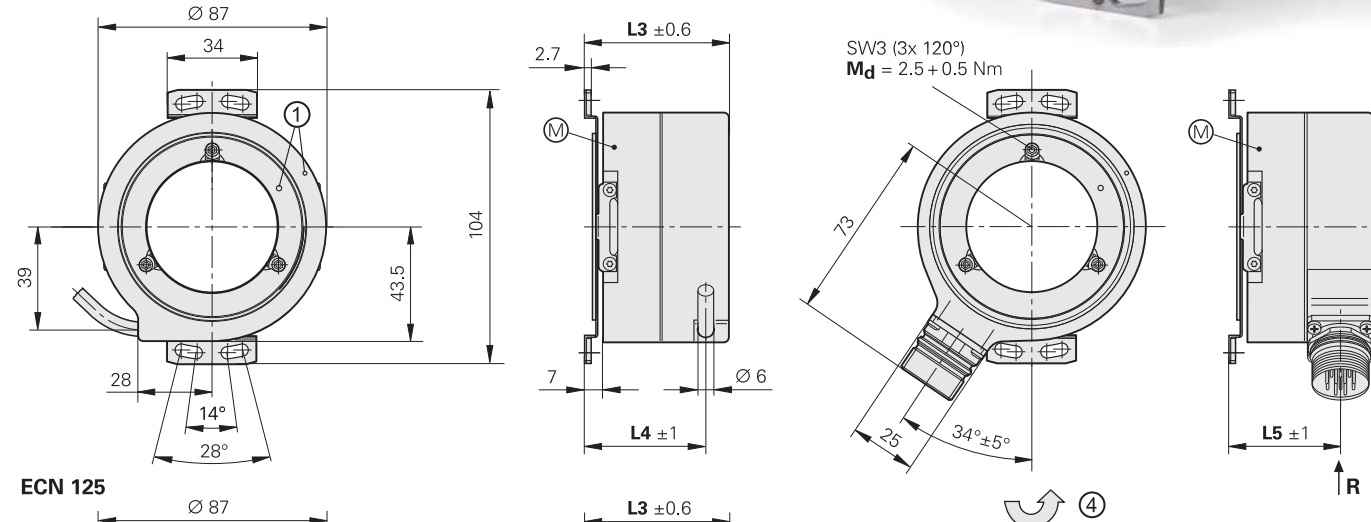

ECN 125

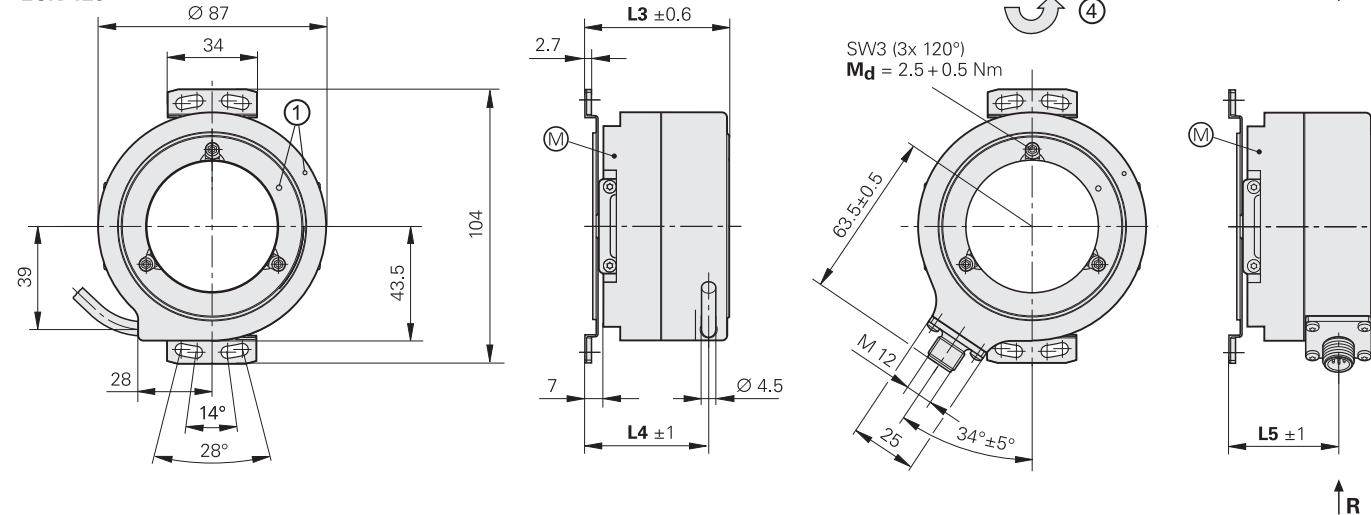

Connector coding
R = Radial

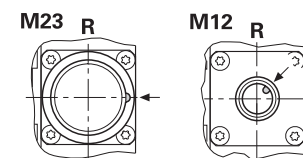

D	L1	L2	L3	L4	L5
Ø 20h7	41	43.5	40	32	26.5
Ø 25h7	41	43.5	40	32	26.5
Ø 38h7	56	58.5	55	47	41.5
Ø 50h7	56	58.5	55	47	41.5

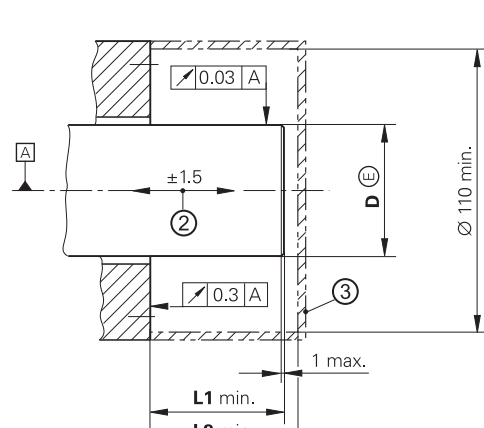
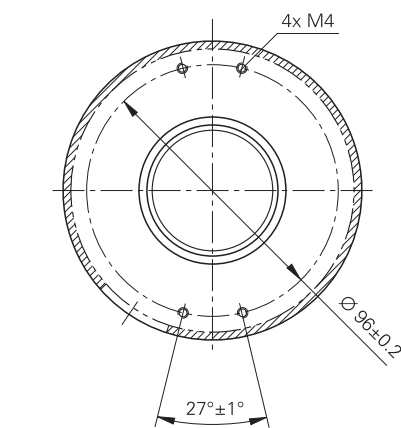

mm
Tolerancing ISO 8015
ISO 2768 - m H
< 6 mm: ±0.2 mm

- Radial cable (can also be used axially)
- A = Bearing
 - ⊙ = Measuring point for operating temperature
 - 1 = ERN: reference mark position ±15°; ECN: zero position ±15°
 - 2 = Compensation of mounting tolerances and thermal expansion; no dynamic motion permitted
 - 3 = Ensure protection against contact (EN 60529)
 - 4 = Direction of shaft rotation for output signals as per the interface description

	Absolute		Incremental		
	Singleturn				
	ECN 125	ECN 113	ERN 120	ERN 130	ERN 180
Interface	EnDat 2.2	EnDat 2.2	□ TTL	□ HTL	~ 1 V _{PP} ²⁾
Ordering designation	EnDat22	EnDat01	-		
Positions per revolution	33554432 (25 bits)	8192 (13 bits)	-		
Code	Pure binary		-		
Elec. perm. shaft speed Deviations ¹⁾	n _{max} for continuous position value	≤ 600 rpm/n _{max} ±1 LSB/±50 LSB	-		
Calculation time t _{cal} Clock frequency	≤ 7 μs ≤ 16 MHz	≤ 9 μs ≤ 2 MHz	-		
Incremental signals	Without	~ 1 V _{PP} ²⁾	□ TTL	□ HTL	~ 1 V _{PP} ²⁾
Line counts*	-	2048	1000	1024	2048 2500 3600 5000
Reference mark	-	-	One		
Cutoff frequency -3 dB	-	≥ 400 kHz typical	-		
Output frequency	-	-	≤ 300 kHz		
Edge separation a	-	-	≥ 0.39 μs		
System accuracy	±20"		1/20 of grating period		
Electrical connection*	<ul style="list-style-type: none"> • M12 flange socket, radial • Cable (1 m/5 m) with M12 coupling 		<ul style="list-style-type: none"> • M23 flange socket, radial • Cable (1 m/5 m) with or without M23 coupling 		<ul style="list-style-type: none"> • M23 flange socket, radial • Cable (1 m/5 m) with or without M23 coupling
Supply voltage	DC 3.6 V to 14 V		DC 5 V ±0.5 V	DC 10 V to 30 V	DC 5 V ±0.5 V
Power consumption (max.)	3.6 V: ≤ 620 mW/14 V: ≤ 720 mW		-		
Current consump. w/o load	5 V: ≤ 85 mA (typical)		≤ 120 mA	≤ 150 mA	≤ 120 mA
Shaft*	Hollow through shaft Ø 20 mm, Ø 25 mm, Ø 38 mm, Ø 50 mm				
Mech. perm. shaft speed n ³⁾	Ø > 30 mm: ≤ 4000 rpm; Ø ≤ 30 mm: ≤ 6000 rpm				
Starting torque (typical) at 20 °C	Ø > 30 mm: 0.2 Nm Ø ≤ 30 mm: 0.15 Nm				
Moment of inertia of rotor/ angular acceleration ⁴⁾	Ø 50 mm 220 · 10 ⁻⁶ kgm ² /≤ 5 · 10 ⁴ rad/s ² ; Ø 38 mm 350 · 10 ⁻⁶ kgm ² /≤ 2 · 10 ⁴ rad/s ² Ø 25 mm 96 · 10 ⁻⁶ kgm ² /≤ 3 · 10 ⁴ rad/s ² ; Ø 20 mm 100 · 10 ⁻⁶ kgm ² /≤ 3 · 10 ⁴ rad/s ²				
Permissible axial motion of measured shaft	±1.5 mm				
Vibration 55 Hz to 2000 Hz Shock 6 ms	≤ 200 m/s ² ; flange socket version: ≤ 100 m/s ² (EN 60068-2-6) ≤ 1000 m/s ² (EN 60068-2-27)				
Max. operating temp. ³⁾	100 °C (85 °C with ERN 130)				
Min. operating temp.	Flange socket or fixed cable: -40 °C; moving cable: -10 °C				
Protection EN 60529	IP64				
Mass	0.6 kg to 0.9 kg depending on the hollow-shaft version				
Valid for ID	810801-xx	810800-xx	589611-xx	589612-xx	589614-xx

Bold: This preferred version is available on short notice. * Please select when ordering

- 1) Speed-dependent deviations between absolute value and incremental signal
- 2) Limited tolerances: signal amplitude: 0.8 V_{PP} to 1.2 V_{PP}
- 3) For the relationship between shaft speed and operating temperature, see *General mechanical information*
- 4) At room temperature, calculated; mating shaft material: 1.4104

ROC/ROQ/ROD 1000 series

Absolute and incremental rotary encoders

- Synchro flange
- Solid shaft for separate shaft coupling



ROC/ROQ

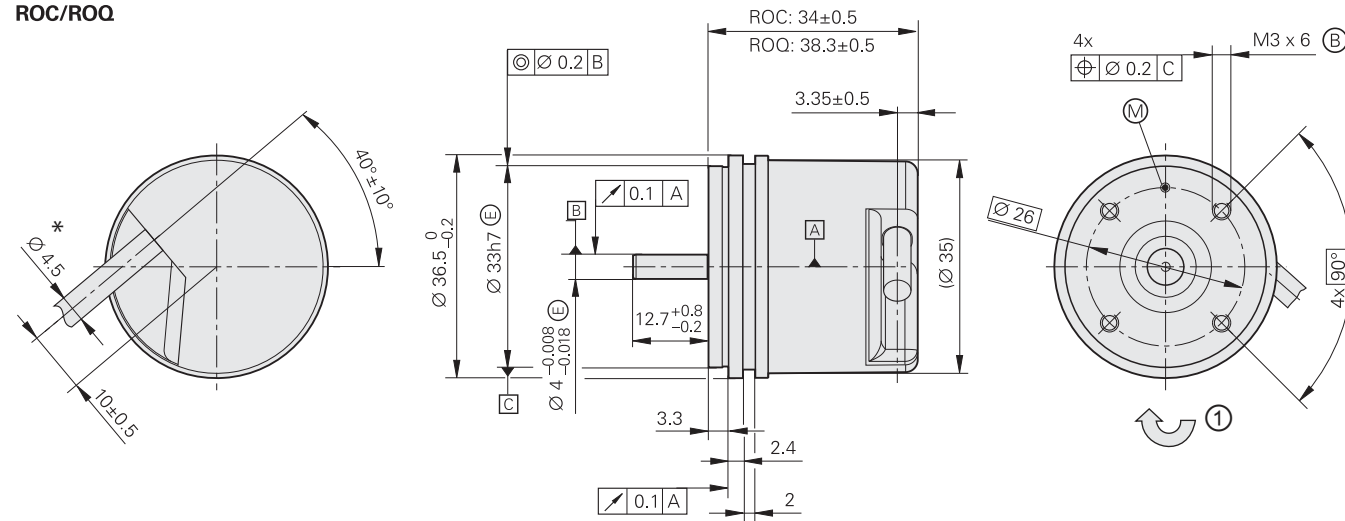

ROD

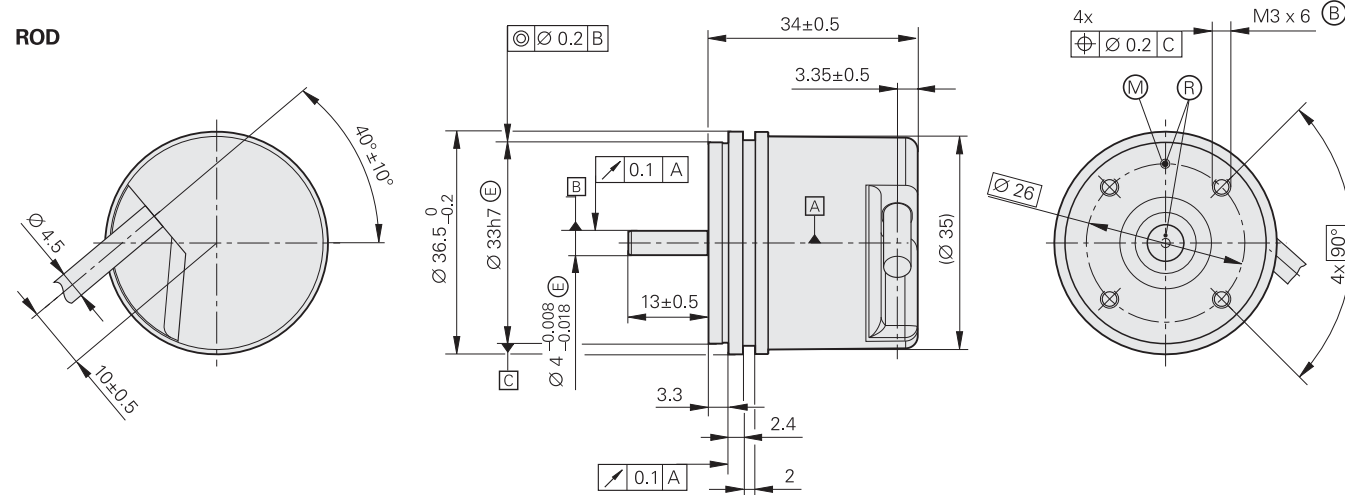

mm

 Tolerancing ISO 8015
 ISO 2768 - m H
 < 6 mm: ± 0.2 mm

Radial cable (can also be used axially)
 * = $\varnothing 3.7$ mm in the case of encoders with DRIVE-CLiQ interface
 A = Bearing
 B = Fastening thread
 M = Measuring point for operating temperature
 R = Reference mark position $\pm 20^{\circ}$
 1 = Direction of shaft rotation for output signals as per the interface description

	Incremental			
	ROD 1020	ROD 1030	ROD 1080	ROD 1070
Interface			$\sim 1 V_{PP}^{1)}$	
Line counts*	100 1000	200 1024	250 360 400 500 720 900 2048 2500 3600	1000 2500 3600
Reference mark	One			
Integrated interpolation*	-		5-fold	10-fold
Cutoff frequency -3 dB	-	-	≥ 180 kHz	-
Scanning frequency	≤ 300 kHz	≤ 160 kHz	-	≤ 100 kHz
Edge separation a	≥ 0.39 μ s	≥ 0.76 μ s	-	≥ 0.47 μ s
System accuracy	1/20 of grating period			
Electrical connection	Cable (1 m/5 m) with or without M23 coupling			Cable (5 m), free cable end
Supply voltage	DC 5 V ± 0.5 V	DC 10 V to 30 V	DC 5 V ± 0.5 V	DC 5 V ± 5 %
Current consumption without load	≤ 120 mA	≤ 150 mA	≤ 120 mA	≤ 155 mA
Shaft	Solid shaft $\varnothing 4$ mm			
Mech. permiss. shaft speed n	≤ 12000 rpm			
Starting torque (typical)	0.001 Nm (at 20 °C)			
Moment of inertia of rotor	$\leq 0.5 \cdot 10^{-6}$ kgm ²			
Shaft load	Axial: 5 N Radial: 10 N at shaft end			
Vibration 55 Hz to 2000 Hz	≤ 100 m/s ² (EN 60068-2-6)			
Shock 6 ms	≤ 1000 m/s ² (EN 60068-2-27)			
Max. operating temp. ²⁾	100 °C	70 °C	100 °C	70 °C
Min. operating temp.	Fixed cable: -30 °C; moving cable: -10 °C			
Protection EN 60529	IP64			
Mass	≈ 0.09 kg			
Valid for ID	534900-x	534901-xx	534904-xx	534903-xx

Bold: This preferred version is available on short notice.

* Please select when ordering

1) Limited tolerances: signal amplitude: $0.8 V_{PP}$ to $1.2 V_{PP}$

2) For the relationship of operating temperature to shaft speed and supply voltage, see *General mechanical information*

	Absolute					
	Singleturn			Multiturn		
	ROC 1023	ROC 1013	ROC 1023 S	ROQ 1035	ROQ 1025	ROQ 1035 S
Interface*	EnDat 2.2	EnDat 2.2	DRIVE-CLiQ	EnDat 2.2	EnDat 2.2	DRIVE-CLiQ
Ordering designation	EnDat22	EnDat01	DQ01	EnDat22	EnDat01	DQ01
Firmware ¹⁾	–	–	01.32.26.53	–	–	01.32.26.53
Positions per revolution	8388608 (23 bits)	8192 (13 bits)	8388608 (23 bits)	8388608 (23 bits)	8192 (13 bits)	8388608 (23 bits)
Revolutions	–			4096 (12 bits)		
Code	Pure binary		Pure binary	Pure binary		Pure binary
Elec. perm. shaft speed Deviations ^{2) 5)}	≤ 12000 rpm for continuous position value	≤ 4000 rpm/≤ 12000 rpm ±1 LSB/±16 LSB	≤ 12000 rpm for continuous position value	≤ 12000 rpm for continuous position value	≤ 4000 rpm/≤ 12000 rpm ±1 LSB/±16 LSB	≤ 12000 rpm for continuous position value
Calculation time t_{cal} Clock frequency	≤ 7 μs ≤ 8 MHz	≤ 9 μs ≤ 2 MHz	≤ 8 μs ³⁾	≤ 7 μs ≤ 8 MHz	≤ 9 μs ≤ 2 MHz	≤ 8 μs ³⁾
Incremental signals	–	~ 1 V _{PP} ⁴⁾	–	–	~ 1 V _{PP} ⁴⁾	–
Line count	–	512	–	–	512	–
Cutoff frequency –3 dB	–	≥ 190 kHz	–	–	≥ 190 kHz	–
System accuracy	±60''					
Electrical connection	Cable (1 m) with M12 coupling	Cable (1 m) with M23 coupling	Cable (1 m) with M12 coupling	Cable (1 m) with M12 coupling	Cable (1 m) with M23 coupling	Cable (1 m) with M12 coupling
Supply voltage	DC 3.6 V to 14 V		DC 10 V to 28.8 V	DC 3.6 V to 14 V		DC 10 V to 28.8 V
Power consumption (maximum)	3.6 V: ≤ 0.6 W 14 V: ≤ 0.7 W		10 V: ≤ 850 mW 28.8 V: ≤ 900 mW	3.6 V: ≤ 0.7 W 14 V: ≤ 0.8 W		10 V: ≤ 950 mW 28.8 V: ≤ 1000 mW
Current consumption (typical, without load)	5 V: 85 mA		24 V: 32 mA	5 V: 105 mA		24 V: 35 mA
Shaft	Solid shaft Ø 4 mm					
Mech. perm. shaft speed n	12000 rpm					
Starting torque (typical)	0.001 Nm (at 20 °C)			0.002 Nm (at 20 °C)		
Moment of inertia of rotor	≈ 0.5 · 10 ⁻⁶ kgm ²					
Shaft load	Axial: 5 N Radial: 10 N at shaft end					
Vibration 55 Hz to 2000 Hz Shock 6 ms	≤ 100 m/s ² (EN 60068-2-6) ≤ 1000 m/s ² (EN 60068-2-27)					
Max. operating temp.	100 °C		95 °C	100 °C		95 °C
Min. operating temp.	Fixed cable: –30 °C; moving cable: –10 °C					
Protection EN 60529	IP64					
Mass	≈ 0.09 kg					
Valid for ID	606693-xx	606691-xx	1211021-xx	606696-xx	606694-xx	1211022-xx

* Please select when ordering

¹⁾ SINAMICS/SIMOTION: ≥ V4.4 HF4; SINUMERIK without safety ≥ V4.4 SP1 HF3 (as per document: "Certified encoders with DRIVE-CLiQ Dependencies on SIMOTION / SINUMERIK and SINAMICS Hardware and Software versions" (version: 12/2018))

²⁾ Speed-dependent deviations between absolute and incremental signals

³⁾ Calculation time TIME_MAX_ACTVAL

⁴⁾ Limited tolerances: signal amplitude: 0.8 V_{PP} to 1.2 V_{PP}

⁵⁾ For the DRIVE-CLiQ interface with ≥ 2 position requests per revolution

ROC/ROQ/ROD 400 series

Absolute and incremental rotary encoders

- Synchro flange
- Solid shaft for separate shaft coupling

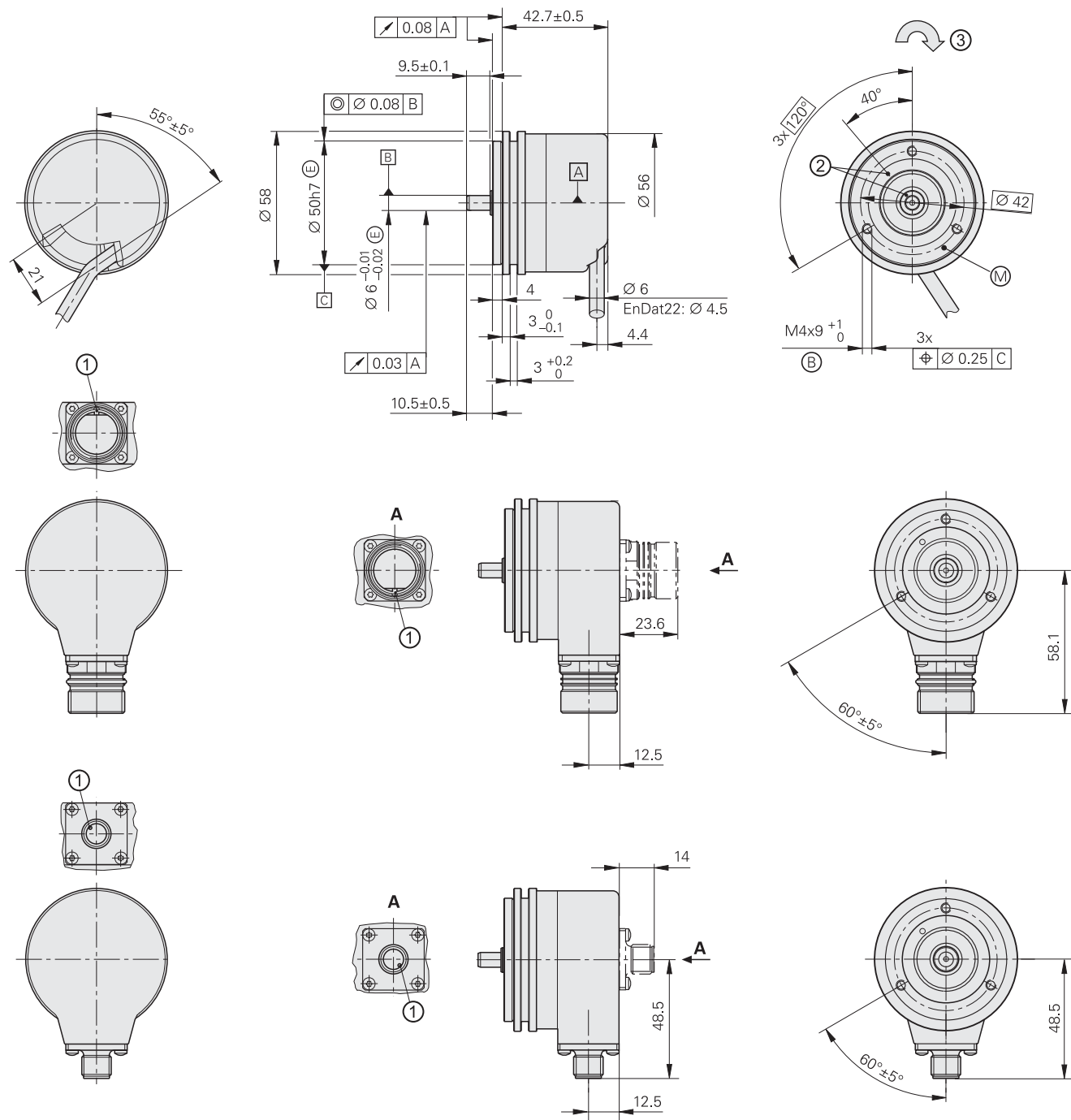

mm
 Tolerancing ISO 8015
 ISO 2768 - m H
 < 6 mm: ±0.2 mm

Radial cable (can also be used axially)
 A = Bearing
 B = Fastening thread
 C = Measuring point for operating temperature
 1 = Connector coding
 2 = ROD reference mark position on shaft and flange ±30°
 3 = Direction of shaft rotation for output signals as per the interface description

	Incremental											
	ROD 426			ROD 466			ROD 436			ROD 486		
Interface	□ TTL						□ HTL			~ 1 V _{PP} ¹⁾		
Line counts*	50	100	150	200	250	360	500	512	720	-		
	1000	1024	1250	1500	1800	2000	2048	2500	3600	4096	5000	
	6000 ²⁾ 8192 ²⁾ 9000 ²⁾ 10000 ²⁾						-					
Reference mark	One											
Cutoff frequency -3 dB	-											≥ 180 kHz
Scanning frequency	≤ 300 kHz/≤ 150 kHz ²⁾											-
Edge separation a	≥ 0.39 μs/≥ 0.25 μs ²⁾											-
System accuracy	1/20 of grating period											
Electrical connection*	<ul style="list-style-type: none"> • M23 flange socket, radial and axial • Cable (1 m/5 m) with or without M23 coupling 											
Supply voltage	DC 5 V ±0.5 V			DC 10 V to 30 V			DC 10 V to 30 V			DC 5 V ±0.5 V		
Current consumption without load	≤ 120 mA			≤ 100 mA			≤ 150 mA			≤ 120 mA		
Shaft	Solid shaft Ø 6 mm											
Mech. permiss. shaft speed n	≤ 16000 rpm											
Starting torque (typical)	0.01 Nm (at 20 °C)											
Moment of inertia of rotor	≤ 2.7 · 10 ⁻⁶ kgm ²											
Shaft load ³⁾	Axial: ≤ 40 N; radial: ≤ 60 N at shaft end											
Vibration 55 Hz to 2000 Hz	≤ 300 m/s ² (EN 60068-2-6)											
Shock 6 ms	≤ 2000 m/s ² (EN 60068-2-27)											
Max. operating temp. ⁴⁾	100 °C			70 °C			100 °C ⁵⁾					
Min. operating temp.	Flange socket or fixed cable: -40 °C; moving cable: -10 °C											
Protection EN 60529	IP67 at housing; IP64 at shaft inlet (IP66 upon request)											
Mass	≈ 0.3 kg											
Valid for ID	376846-xx			376866-xx			376836-xx			376886-xx ⁶⁾		

Bold: This preferred version is available on short notice.

* Please select when ordering

¹⁾ Limited tolerances: signal amplitude: 0.8 V_{PP} to 1.2 V_{PP}



²⁾ Signal periods; they are generated via 2-fold interpolation (TTL x 2)

³⁾ See also *Mechanical design types and mounting*

⁴⁾ For the relationship of operating temperature to shaft speed and supply voltage, see *General mechanical information*

⁵⁾ 80 °C for ROD 486 with 4096 or 5000 lines

⁶⁾ Available with mechanical fault exclusion; for deviating specifications and special mounting information, see the *Fault Exclusion Customer Information document*

	Absolute			Multiturn		
	Singleturn ROC 425 		ROC 413	ROQ 437 		ROQ 425
Interface*	EnDat 2.2	EnDat 2.2	SSI	EnDat 2.2	EnDat 2.2	SSI
Ordering designation	EnDat22	EnDat01	SSI39r1	EnDat22	EnDat01	SSI41r1
Positions per revolution	33554432 (25 bits)	8192 (13 bits)		33554432 (25 bits)	8192 (13 bits)	8192 (13 bits)
Revolutions	–			4096		
Code	Pure binary		Gray	Pure binary		Gray
Elec. permiss. shaft speed Deviations ¹⁾	≤ 15000 rpm for continuous position value	<i>512 lines:</i> ≤ 5000/12000 rpm ±1 LSB/±100 LSB <i>2048 lines:</i> ≤ 1500/12000 rpm ±1 LSB/±50 LSB	12000 rpm ±12 LSB	≤ 15000 rpm for continuous position value	<i>512 lines:</i> ≤ 5000/10000 rpm ±1 LSB/±100 LSB <i>2048 lines:</i> ≤ 1500/10000 rpm ±1 LSB/±50 LSB	12000 rpm ±12 LSB
Calculation time t_{cal} Clock frequency	≤ 7 μs ≤ 8 MHz	≤ 9 μs ≤ 2 MHz	≤ 5 μs –	≤ 7 μs ≤ 8 MHz	≤ 9 μs ≤ 2 MHz	≤ 5 μs –
Incremental signals	Without	$\sim 1 V_{PP}$ ²⁾		Without	$\sim 1 V_{PP}$ ²⁾	
Line counts*	–	512 2048	512	–	512 2048	512
Cutoff frequency –3 dB	–	<i>512 lines:</i> ≥ 130 kHz; <i>2048 Str.:</i> ≥ 400 kHz		–	<i>512 lines:</i> ≥ 130 kHz; <i>2048 lines:</i> ≥ 400 kHz	
System accuracy	±20"	<i>512 lines:</i> ±60"; <i>2048 lines:</i> ±20"		±20"	<i>512 lines:</i> ±60"; <i>2048 lines:</i> ±20"	
Electrical connection*	<ul style="list-style-type: none"> • M12 flange socket, radial • Cable (1 m) with M12 coupling 	<ul style="list-style-type: none"> • M23 flange socket, axial or radial • Cable (1 m/5 m) with or without M23 coupling 		<ul style="list-style-type: none"> • M12 flange socket, radial • Cable (1 m) with M12 coupling 	<ul style="list-style-type: none"> • M23 flange socket, axial or radial • Cable (1 m/5 m) with or without M23 coupling 	
Supply voltage	DC 3.6 V to 14 V	DC 3.6 V to 14 V	DC 4.75 V to 30 V	DC 3.6 V to 14 V	DC 3.6 V to 14 V	DC 4.75 V to 30 V
Power consumption (max.)	3.6 V: ≤ 0.6 W 14 V: ≤ 0.7 W	5 V: ≤ 0.8 W 10 V: ≤ 0.65 W 30 V: ≤ 1 W		3.6 V: ≤ 0.7 W 14 V: ≤ 0.8 W	5 V: ≤ 0.95 W 10 V: ≤ 0.75 W 30 V: ≤ 1.1 W	
Current consumption (typical, without load)	5 V: 85 mA	5 V: 90 mA 24 V: 24 mA		5 V: 105 mA	5 V: 120 mA 24 V: 28 mA	
Shaft	Solid shaft Ø 6 mm					
Mech. permiss. shaft speed n	≤ 15000 rpm			≤ 12000 rpm		
Starting torque (typical)	0.01 Nm (at 20 °C)					
Moment of inertia of rotor	≤ 2.7 · 10 ⁻⁶ kgm ²					
Shaft load	<i>Axial:</i> ≤ 40 N; <i>radial:</i> ≤ 60 N at shaft end (see also <i>Mechanical design types and mounting</i>)					
Vibration 55 Hz to 2000 Hz Shock 6 ms	≤ 300 m/s ² (EN 60068-2-6) <i>ROC/ROQ:</i> ≤ 2000 m/s ² ; <i>RIC/RIQ:</i> ≤ 1000 m/s ² (EN 60068-2-27)					
Max. operating temp. ³⁾	100 °C					
Min. operating temp.	<i>Flange socket or fixed cable:</i> –40 °C; <i>moving cable:</i> –10 °C					
Protection EN 60529	IP67 at housing; IP64 at shaft inlet (IP66 upon request)					
Mass	≈ 0.35 kg					
Valid for ID	683639-xx ⁴⁾ / 1322268-xx ^{4) 5)}	1109254-xx	1131750-xx / 1353113-xx ⁵⁾	683641-xx ⁴⁾ / 1322273-xx ^{4) 5)}	1109256-xx	1131752-xx / 1353117-xx ⁵⁾

Bold: This preferred version is available on short notice.

* Please select when ordering

¹⁾ Speed-dependent deviations between absolute value and incremental signal

²⁾ Limited tolerances: signal amplitude: 0.8 V_{PP} to 1.2 V_{PP}

³⁾ For the relationship of operating temperature to shaft speed and supply voltage, see *General mechanical information*

⁴⁾ Also available with functional safety; for dimensions and specifications, see Product Information document

⁵⁾ Successor variants

ROQ 425

Rotary encoder for absolute position values with solid shaft
for separate shaft coupling

- EnDat interface
- Additional incremental signals with TTL or HTL levels

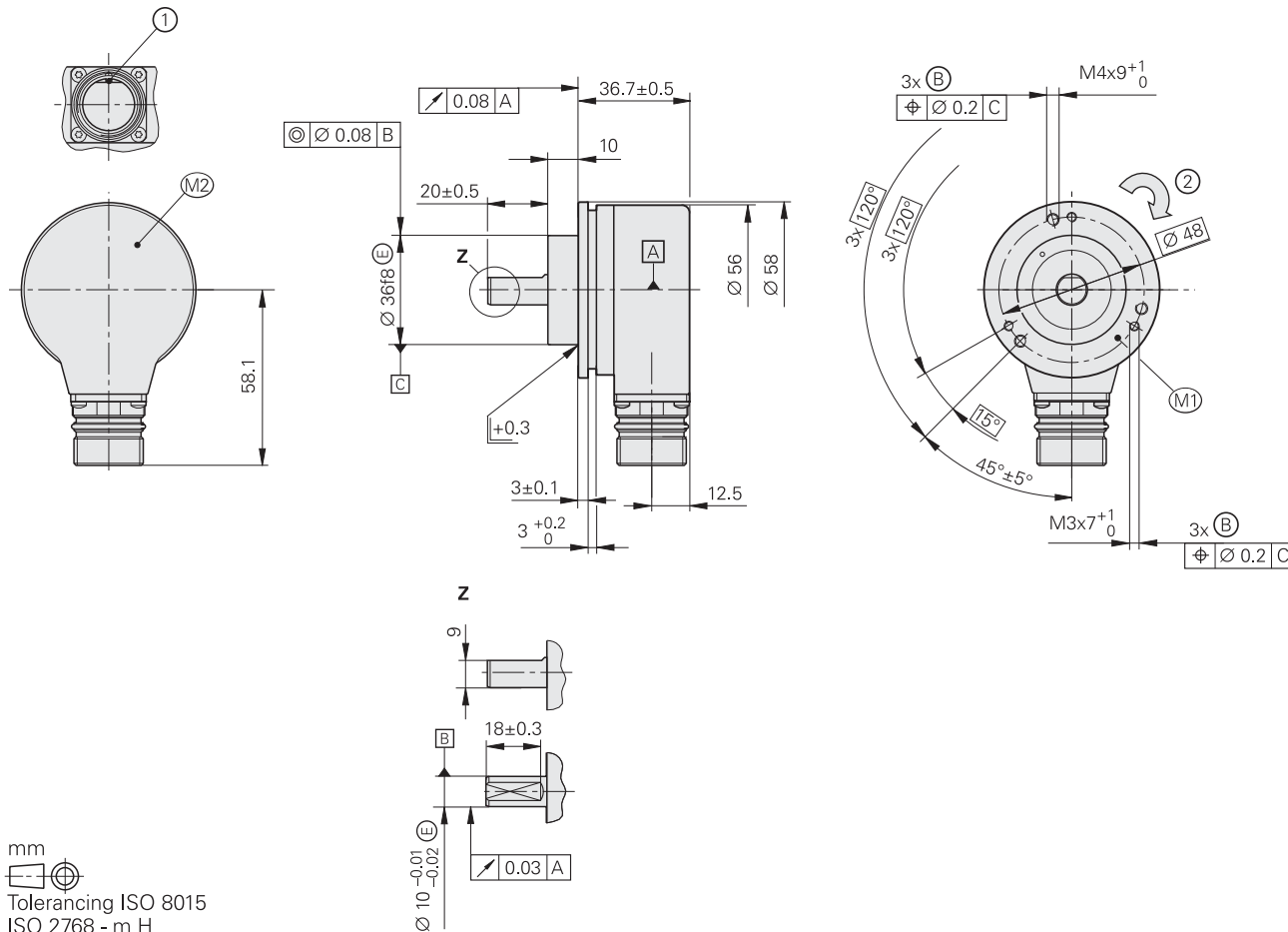

mm
Tolerancing ISO 8015
ISO 2768 - m H
< 6 mm: ±0.2 mm

- ▣ = Bearing
- ⊕ = Fastening thread
- M1 = Measuring point for operating temperature
- M2 = Measuring point for vibration, see also D 774714
- 1 = Connector coding
- 2 = Direction of shaft rotation for output signals as per the interface description

	Absolute					
	Multiturn					
	ROQ 425					
Interface	EnDat 2.2					
Ordering designation*	EnDatH			EnDatT		
Positions per revolution	8192 (13 bits)					
Revolutions	4096 (12 bits)					
Code	Pure binary					
Calculation time t_{cal}	≤ 9 μs					
Clock frequency	≤ 2 MHz					
Incremental signals	HTL			TTL		
Signal periods *	512	1024	2048	512	2048	4096
Edge separation a	≥ 2.4 μs	≥ 0.8 μs	≥ 0.6 μs	≥ 2.4 μs	≥ 0.6 μs	≥ 0.2 μs
Output frequency	≤ 52 kHz	≤ 103 kHz	≤ 205 kHz	≤ 52 kHz	≤ 205 kHz	≤ 410 kHz
System accuracy ¹⁾	±60"	±60"	±20"	±60"	±20"	±20"
Electrical connection	17-pin M23 radial flange socket (male)					
Cable length ²⁾	≤ 100 m (with HEIDENHAIN cable)					
Supply voltage	DC 10 V to 30 V			DC 4.75 V to 30 V		
Power consumption (max.) ³⁾	See Power consumption diagram			At 4.75 V: ≤ 900 mW At 30 V: ≤ 1100 mW		
Current consumption (typical, without load)	At 10 V: ≤ 56 mA At 24 V: ≤ 34 mA			At 5 V: ≤ 100 mA At 24 V: ≤ 25 mA		
Shaft	Solid shaft Ø 10 mm with flat					
Mech. permitt. shaft speed $n^4)$	≤ 12000 rpm					
Starting torque (typical)	0.025 Nm (at 20 °C)					
Moment of inertia of rotor	$2.7 \cdot 10^{-6} \text{ kgm}^2$					
Shaft load	Axial: ≤ 40 Nm Radial: ≤ 60 Nm at shaft end (see also Mechanical design types and mounting)					
Vibration 10 Hz to 2000 Hz ⁵⁾	≤ 150 m/s ² (EN 60068-2-6)					
Shock 6 ms	≤ 1000 m/s ² (EN 60068-2-27)					
Max. operating temp. ⁴⁾	100 °C					
Min. operating temp.	-40 °C					
Protection EN 60529	Housing: IP67 Shaft exit: IP66					
Mass	≈ 0.30 kg					
Valid for ID	1042530-xx			1042529-xx		

* Please select when ordering

1) For absolute position value; accuracy of the incremental signal upon request

2) For HTL signals, the maximum cable length depends on the output frequency (see the Cable length for HTL diagrams)

3) See General electrical information in the Interfaces of HEIDENHAIN Encoders brochure

4) For the relationship of operating temperature to shaft speed and supply voltage, see General mechanical information

5) 10 Hz to 55 Hz constant over 4.9 mm peak to peak

ROQ 425

Rotary encoder for absolute position values with solid shaft
for separate shaft coupling

- SSI interface
- Additional incremental signals with TTL or HTL levels

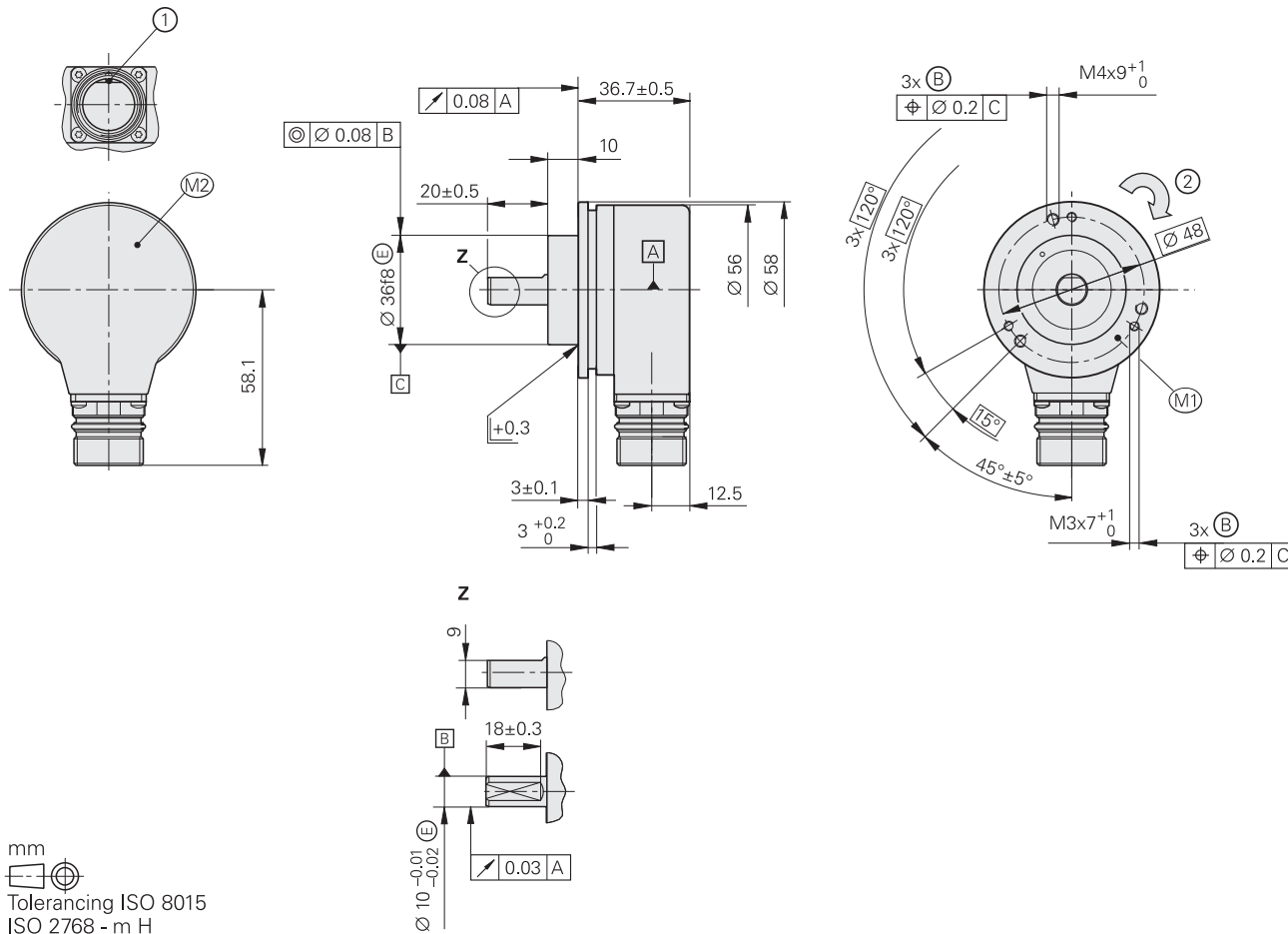

mm
Tolerancing ISO 8015
ISO 2768 - m H
< 6 mm: ±0.2 mm

- ⊠ = Bearing
- ⊕ = Fastening thread
- M1 = Measuring point for operating temperature
- M2 = Measuring point for vibration, see also D 774714
- 1 = Connector coding
- 2 = Direction of shaft rotation for output signals as per the interface description

	Absolute					
	Multiturn					
	ROQ 425					
Interface	SSI					
Ordering designation*	SSI41H			SSI41T		
Positions per revolution	8192 (13 bits)					
Revolutions	4096 (12 bits)					
Code	Pure binary					
Calculation time t_{cal}	≤ 9 μs					
Clock frequency	≤ 2 MHz					
Incremental signals	HTL ⁶⁾			TTL		
Signal periods *	512	1024	2048	512	2048	4096
Edge separation a	≥ 2.4 μs	≥ 0.8 μs	≥ 0.6 μs	≥ 2.4 μs	≥ 0.6 μs	≥ 0.2 μs
Output frequency	≤ 52 kHz	≤ 103 kHz	≤ 205 kHz	≤ 52 kHz	≤ 205 kHz	≤ 410 kHz
System accuracy ¹⁾	±60"	±60"	±20"	±60"	±20"	±20"
Electrical connection	12-pin M23 radial flange socket (male)			17-pin M23 radial flange socket (male)		
Cable length ²⁾	≤ 100 m (with HEIDENHAIN cable)					
Supply voltage	DC 10 V to 30 V			DC 4.75 V to 30 V		
Power consumption (max.) ³⁾	See <i>Power consumption</i> diagram			At 4.75 V: ≤ 900 mW At 30 V: ≤ 1100 mW		
Current consumption (typical, without load)	At 10 V: ≤ 56 mA At 24 V: ≤ 34 mA			At 5 V: ≤ 100 mA At 24 V: ≤ 25 mA		
Shaft	Solid shaft Ø 10 mm with flat					
Mech. permitt. shaft speed $n^4)$	≤ 12000 rpm					
Starting torque (typical)	0.025 Nm (at 20 °C)					
Moment of inertia of rotor	$2.7 \cdot 10^{-6} \text{ kgm}^2$					
Shaft load	<i>Axial</i> : ≤ 40 Nm <i>Radial</i> : ≤ 60 Nm at shaft end (see also <i>Mechanical design types and mounting</i>)					
Vibration 10 Hz to 2000 Hz ⁵⁾	≤ 150 m/s ² (EN 60068-2-6)					
Shock 6 ms	≤ 1000 m/s ² (EN 60068-2-27)					
Max. operating temp. ⁴⁾	100 °C					
Min. operating temp.	-40 °C					
Protection EN 60529	<i>Housing</i> : IP67 <i>Shaft exit</i> : IP66					
Mass	≈ 0.30 kg					
Valid for ID	1065028-xx			1042524-xx		

* Please select when ordering

1) For absolute position value; accuracy of the incremental signal upon request

2) For HTL signals, the maximum cable length depends on the output frequency (see the *Cable length for HTL* diagrams)

3) See *General electrical information* in the *Interfaces of HEIDENHAIN Encoders* brochure

4) For the relationship of operating temperature to shaft speed and supply voltage, see *General mechanical information*

5) 10 Hz to 55 Hz constant over 4.9 mm peak to peak

6) HTLs upon request

ROC/ROQ 400F/S series

Absolute rotary encoders

- Synchro flange
- Solid shaft for separate shaft coupling
- Fanuc Serial Interface or Siemens DRIVE-CLiQ interface



ROC/ROQ 400F/M

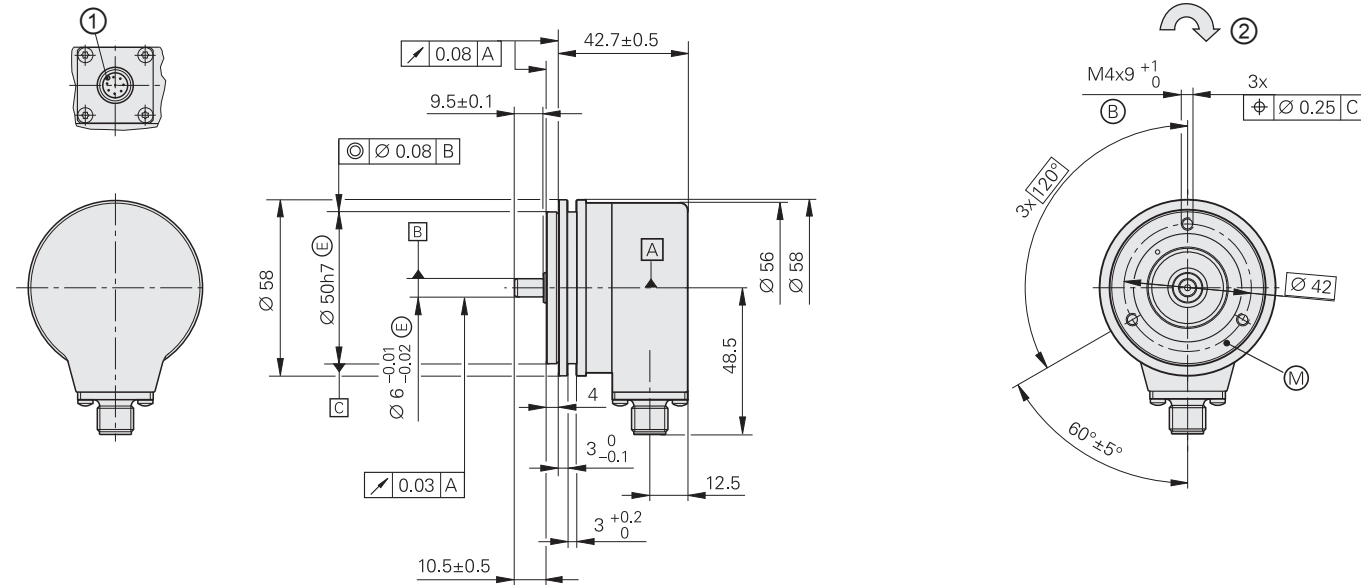

ROC/ROQ 400S

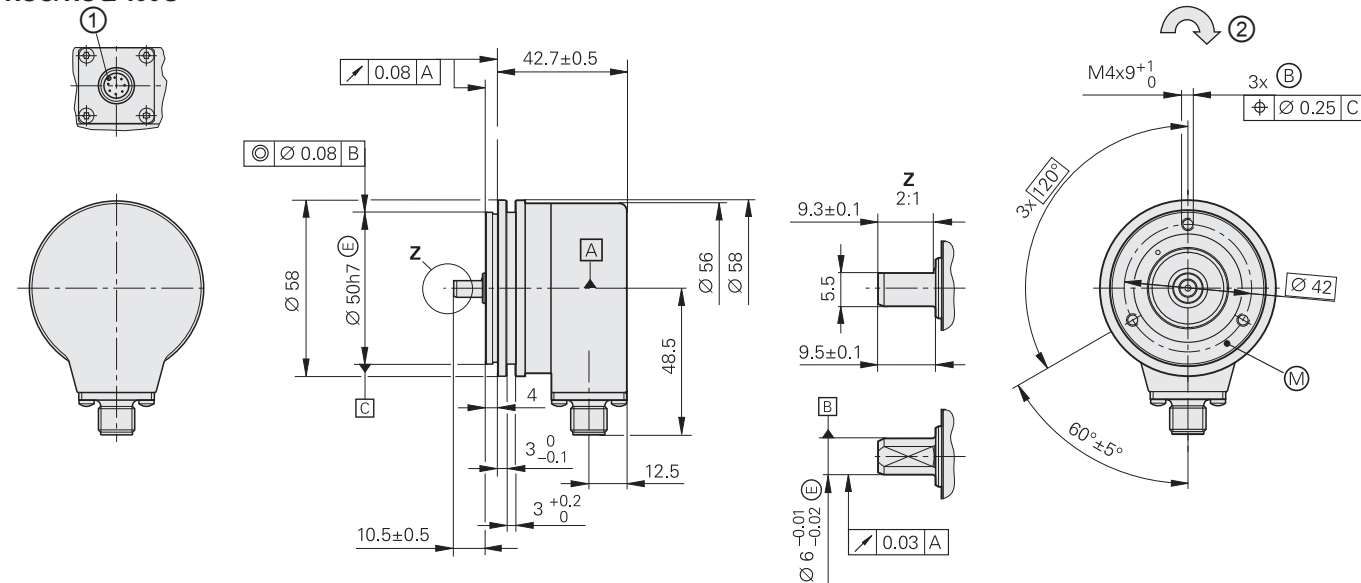

mm
 Tolerancing ISO 8015
 ISO 2768 - m H
 < 6 mm: ±0.2 mm

- ▭ = Bearing
- ⊙ = Fastening thread
- Ⓜ = Measuring point for operating temperature
- 1 = Connector coding
- 2 = Direction of shaft rotation for output signals as per the interface description

DRIVE-CLiQ is a registered trademark of Siemens AG.

	Absolute		Multiturn	
	Singleturn		ROQ 437F	ROQ 436S
	ROC 425F	ROC 424S		
Interface	Fanuc Serial Interface; α i Interface	DRIVE-CLiQ	Fanuc Serial Interface; α i Interface	DRIVE-CLiQ
Ordering designation	Fanuc05 ¹⁾	DQ01	Fanuc06 ¹⁾	DQ01
Positions per revolution	α i: 33554432 (25 bits) α : 8388608 (23 bits)	16777216 (24 bits)	33554432 (25 bits)	16777216 (24 bits)
Revolutions	8192 via revolution counter		α i: 4096	4096
Code	Pure binary			
Elec. perm. shaft speed	≤ 15000 rpm for continuous position value			
Calculation time t_{cal}	≤ 5 μ s	≤ 8 μ s ²⁾	≤ 5 μ s	≤ 8 μ s ²⁾
System accuracy	±20"			
Electrical connection	M12 flange socket, radial			
Cable length	≤ 30 m	≤ 95 m ³⁾	≤ 30 m	≤ 95 m ³⁾
DC supply voltage	3.6 V to 14 V	10 V to 36 V	3.6 V to 14 V	10 V to 36 V
Power consumption (max.)	5 V: ≤ 0.7 W 14 V: ≤ 0.8 W	10 V: ≤ 1.4 W 36 V: ≤ 1.5 W	5 V: ≤ 0.75 W 14 V: ≤ 0.85 W	10 V: ≤ 1.4 W 36 V: ≤ 1.5 W
Current consumption (typical, without load)	5 V: 90 mA	24 V: 37 mA	5 V: 100 mA	24 V: 43 mA
Shaft	Solid shaft \varnothing 6 mm (for ROC 424-S and ROQ 436-S with flat)			
Mech. perm. shaft speed $n^4)$	≤ 15000 rpm		≤ 12000 rpm	
Starting torque (typical)	0.01 Nm (at 20 °C)			
Moment of inertia of rotor	≤ 2.9 · 10 ⁻⁶ kgm ²			
Shaft load	Axial: 40 N; radial: 60 N at shaft end (see also <i>Mechanical design types and mounting</i>)			
Vibration 55 Hz to 2000 Hz Shock 6 ms	≤ 300 m/s ² (EN 60068-2-6) ≤ 2000 m/s ² (EN 60068-2-27)			
Max. operating temp. ⁴⁾	100 °C			
Min. operating temp.	-30 °C			
Protection EN 60529	IP67 at housing; IP64 at shaft inlet			
Mass	≈ 0.35 kg			
Valid for ID	1081305-xx	1036789-xx ⁵⁾	1081303-xx	1036786-xx ⁵⁾

1) Optimized for Fanuc machine tool controls.

2) Calculation time TIME_MAX_ACTVAL

3) See the *Interfaces of HEIDENHAIN Encoders* brochure; with $n_{EN} = 1$ (including adapter cable)

4) For the relationship of operating temperature to shaft speed and supply voltage, see *General mechanical information*

5) Also available with functional safety; for dimensions and specifications, see Product Information document

ROC 425 series

Absolute rotary encoders

- Steel synchro flange
- High accuracy
- Solid shaft for separate shaft coupling
- Version with stainless steel housing

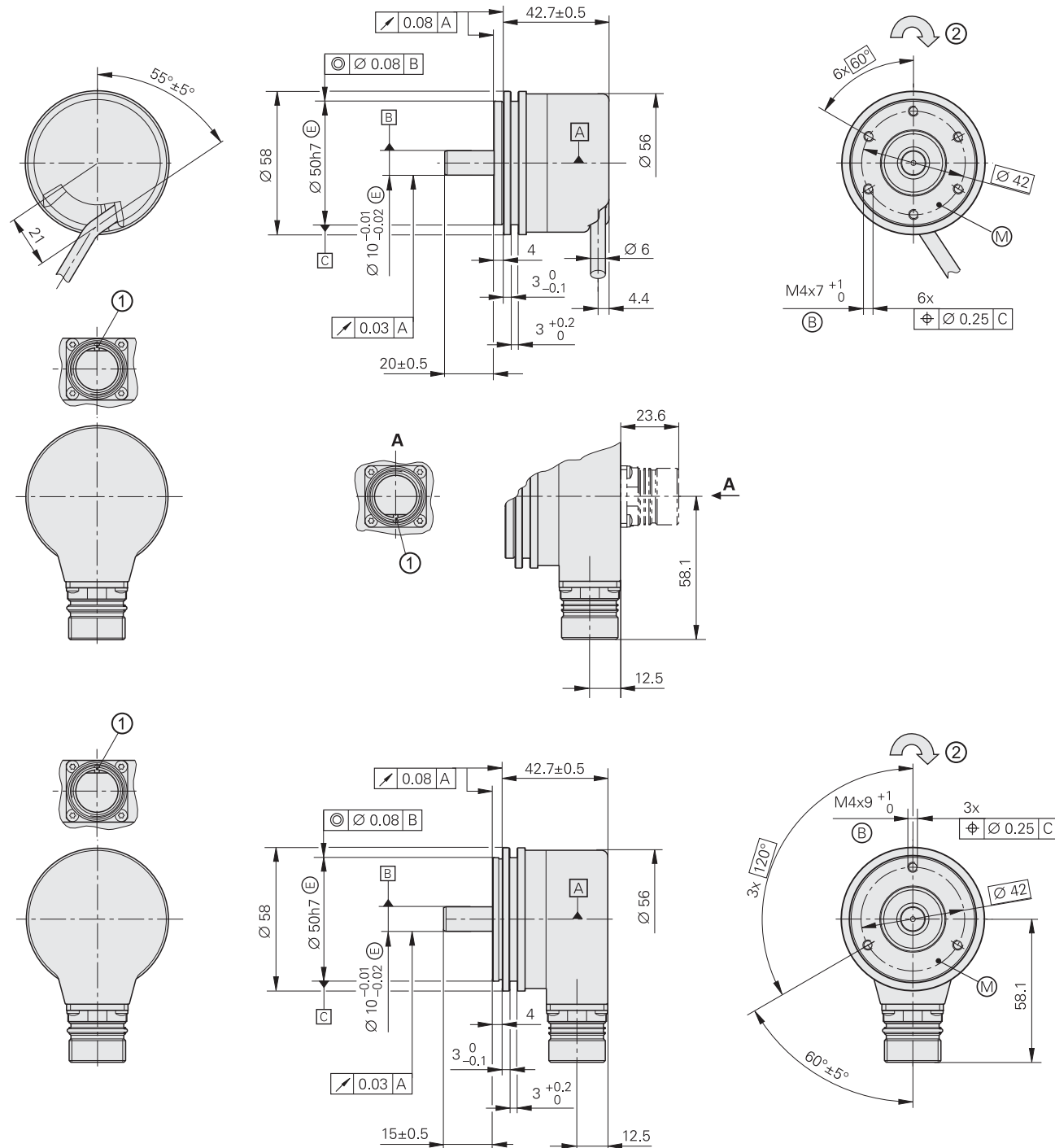

mm
 Tolerancing ISO 8015
 ISO 2768 - m H
 < 6 mm: ±0.2 mm

Radial cable (can also be used axially)

- ▣ = Bearing
- ⊙ = Fastening thread
- ⊕ = Measuring point for operating temperature
- 1 = Connector coding
- 2 = Direction of shaft rotation for output signals as per the interface description

Stainless steel version	Material
Shaft	1.4104
Flange, housing, flange socket	1.4301 (V2A)

	Absolute	Singleturn
	ROC 425, steel	
	ROC 425, stainless steel	
Interface	EnDat 2.2	
Ordering designation	EnDat01	
Positions per revolution	33554432 (25 bits)	
Revolutions	-	
Code	Pure binary	
Elec. perm. shaft speed Deviations ¹⁾	≤ 1500/15000 rpm ±1200 LSB/±9200 LSB	
Calculation time t_{cal} Clock frequency	≤ 9 μs ≤ 2 MHz	
Incremental signals	~ 1 V _{PP}	
Line count	2048	
Cutoff frequency -3 dB	≥ 400 kHz	
System accuracy	±10"	
Electrical connection*	<ul style="list-style-type: none"> • M23 flange socket, axial or radial • Cable (1 m/5 m) with or without M23 coupling 	M23 flange socket, radial
Supply voltage	DC 3.6 V to 14 V	
Power consumption (max.)	3.6 V: ≤ 0.6 W 14 V: ≤ 0.7 W	
Current consumption (typical, without load)	5 V: 85 mA	
Shaft	Solid shaft Ø 10 mm, length 20 mm	Solid shaft Ø 10 mm, length 15 mm
Mech. perm. shaft speed n	≤ 12000 rpm	
Starting torque (typical)	0.025 Nm (at 20 °C)	0.025 Nm (at 20 °C)
Moment of inertia of rotor	≤ 2.1 · 10 ⁻⁶ kgm ²	
Shaft load	Axial: ≤ 40 N; radial: ≤ 60 N at shaft end (see also <i>Mechanical design types and mounting</i>)	
Vibration 55 Hz to 2000 Hz Shock 6 ms	≤ 300 m/s ² (EN 60068-2-6) ≤ 2000 m/s ² (EN 60068-2-27)	
Max. operating temp. ³⁾	80 °C	
Min. operating temp.	Flange socket or fixed cable: -40 °C; moving cable: -10 °C	
Protection EN 60529	IP67 at housing; IP66 at shaft inlet	
Mass	≈ 0.50 kg	≈ 0.55 kg
Valid for ID	638726-xx / 1350876-xx ⁴⁾	1080335-xx

Bold: This preferred version is available on short notice.

* Please select when ordering

1) Speed-dependent deviations between absolute value and incremental signal

2) Limited tolerances: signal amplitude: 0.8 V_{PP} to 1.2 V_{PP}

3) For the relationship of operating temperature to shaft speed and supply voltage, see *General mechanical information*

4) Successor variant

ROC/ROQ/ROD 400 series

Absolute and incremental rotary encoders

- Clamping flange
- Solid shaft for separate shaft coupling

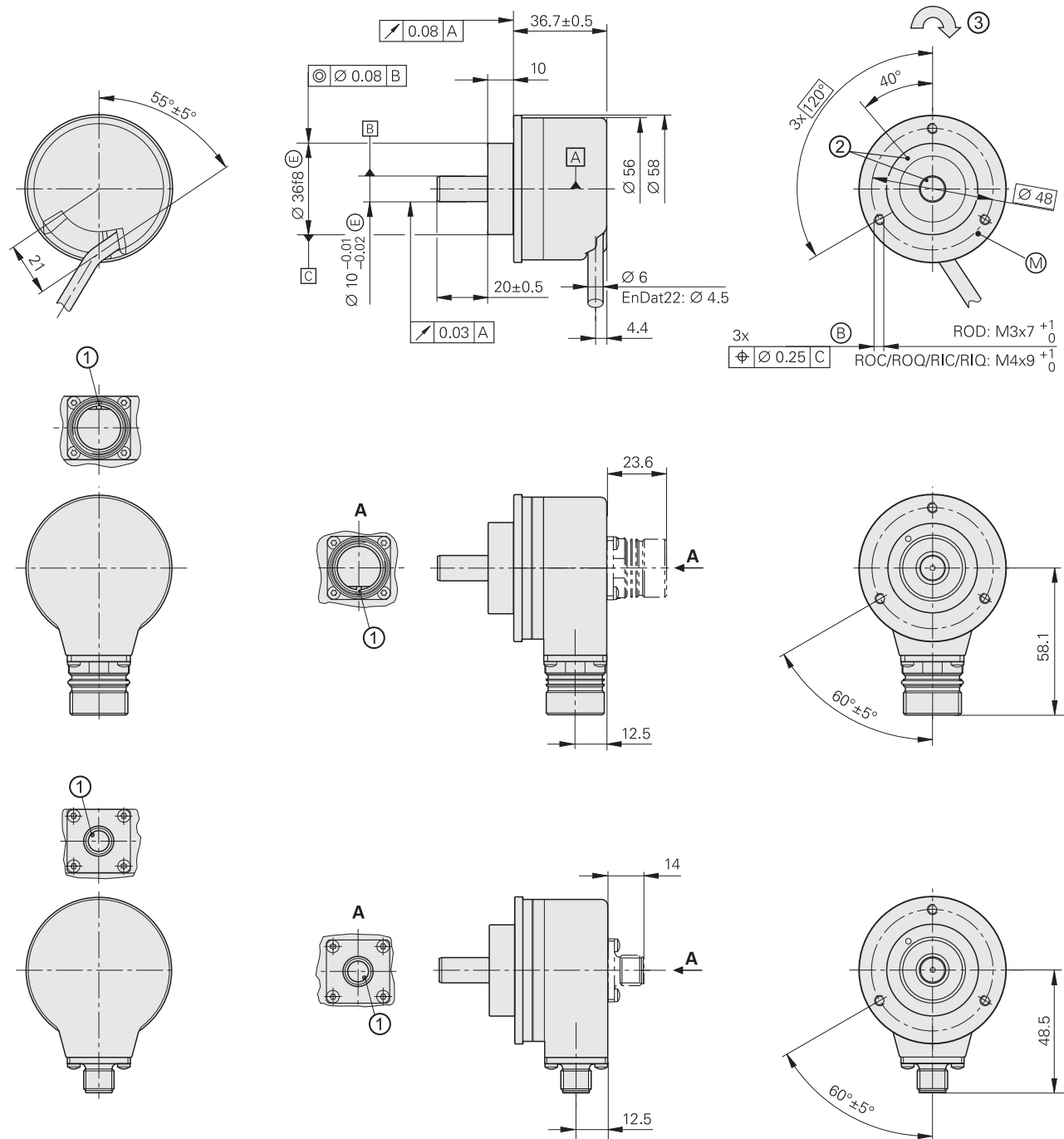

mm

 Tolerancing ISO 8015
 ISO 2768 - m H
 < 6 mm: ±0.2 mm

- Radial cable (can also be used axially)
- ▣ = Bearing
 - ⊙ = Fastening thread
 - ⊗ = Measuring point for operating temperature
 - 1 = Connector coding
 - 2 = ROD reference mark position on shaft and flange ±15°
 - 3 = Direction of shaft rotation for output signals as per the interface description

	Incremental										
	ROD 420					ROD 430			ROD 480		
Interface	□ TTL					□ HTL			~ 1 V _{PP} ¹⁾		
Line counts*	50	100	150	200	250	360	500	512	720	-	
	1000	1024	1250	1500	1800	2000	2048	2500	3600	4096	5000
Reference mark	One										
Cutoff frequency -3 dB	-									≥ 180 kHz	
Output frequency	≤ 300 kHz									-	
Edge separation a	≥ 0.39 μs									-	
System accuracy	1/20 of grating period										
Electrical connection*	<ul style="list-style-type: none"> • M23 flange socket, radial and axial • Cable (1 m/5 m) with or without M23 coupling 										
Supply voltage	DC 5 V ±0.5 V					DC 10 V to 30 V			DC 5 V ±0.5 V		
Current consumption without load	≤ 120 mA					≤ 150 mA			≤ 120 mA		
Shaft	Solid shaft Ø 10 mm										
Mech. permitt. shaft speed n	≤ 16000 rpm										
Starting torque (typical)	0.01 Nm (at 20 °C)										
Moment of inertia of rotor	≤ 2.1 · 10 ⁻⁶ kgm ²										
Shaft load ²⁾	Axial: ≤ 40 N; radial: ≤ 60 N at shaft end										
Vibration 55 Hz to 2000 Hz	≤ 300 m/s ² (EN 60068-2-6)										
Shock 6 ms	≤ 2000 m/s ² (EN 60068-2-27)										
Max. operating temp. ³⁾	100 °C (80 °C for ROD 480 with 4096 or 5000 lines)										
Min. operating temp.	Flange socket or fixed cable: -40 °C Moving cable: -10 °C										
Protection EN 60529	IP67 at housing; IP64 at shaft inlet (IP66 upon request)										
Mass	≈ 0.3 kg										
Valid for ID	376840-xx					376834-xx			376880-xx ⁴⁾		

Bold: This preferred version is available on short notice.



* Please select when ordering

¹⁾ Limited tolerances: signal amplitude: 0.8 V_{PP} to 1.2 V_{PP}

²⁾ See also *Mechanical design types and mounting*

³⁾ For the relationship of operating temperature to shaft speed and supply voltage, see *General mechanical information*

⁴⁾ Available with mechanical fault exclusion; for deviating specifications and special mounting information, see the *Fault Exclusion Customer Information document*

	Absolute			Multiturn		
	Singleturn ROC 425 	ROC 413	SSI	ROQ 437 	ROQ 425	
Interface*	EnDat 2.2	EnDat 2.2	SSI	EnDat 2.2	EnDat 2.2	SSI
Ordering designation	EnDat22	EnDat01	SSI39r1	EnDat22	EnDat01	SSI41r1
Positions per revolution	33 554 432 (25 bits)	8192 (13 bits)		33 554 432 (25 bits)	8192 (13 bits)	
Revolutions	–			4096		
Code	Pure binary		Gray	Pure binary		Gray
Elec. permiss. shaft speed Deviations ¹⁾	≤ 15000 rpm for continuous position value	<i>512 lines:</i> ≤ 5000/12000 rpm ±1 LSB/±100 LSB <i>2048 lines:</i> ≤ 1500/12000 rpm ±1 LSB/±50 LSB	12000 rpm ±12 LSB	≤ 15000 rpm for continuous position value	<i>512 lines:</i> ≤ 5000/10000 rpm ±1 LSB/±100 LSB <i>2048 lines:</i> ≤ 1500/10000 rpm ±1 LSB/±50 LSB	12000 rpm ±12 LSB
Calculation time t_{cal} Clock frequency	≤ 7 μs ≤ 8 MHz	≤ 9 μs ≤ 2 MHz	≤ 5 μs –	≤ 7 μs ≤ 8 MHz	≤ 9 μs ≤ 2 MHz	≤ 5 μs –
Incremental signals	Without	$\sim 1 V_{PP}^{2)}$		Without	$\sim 1 V_{PP}^{2)}$	
Line counts*	–	512 2048	512	–	512 2048	512
Cutoff frequency –3 dB	–	<i>512 lines:</i> ≥ 130 kHz; <i>2048 lines:</i> ≥ 400 kHz		–	<i>512 lines:</i> ≥ 130 kHz; <i>2048 lines:</i> ≥ 400 kHz	
System accuracy¹⁾	±20"	<i>512 lines:</i> ±60"; <i>2048 lines:</i> ±20"		±20"	<i>512 lines:</i> ±60"; <i>2048 lines:</i> ±20"	
Electrical connection*	<ul style="list-style-type: none"> • M12 flange socket, radial • Cable (1 m) with M12 coupling 	<ul style="list-style-type: none"> • M23 flange socket, axial or radial • Cable (1 m/5 m) with or without M23 coupling 		<ul style="list-style-type: none"> • M12 flange socket, radial • Cable (1 m) with M12 coupling 	<ul style="list-style-type: none"> • M23 flange socket, axial or radial • Cable (1 m/5 m) with or without M23 coupling 	
Supply voltage	DC 3.6 V to 14 V	DC 3.6 V to 14 V	DC 4.75 V to 30 V	DC 3.6 V to 14 V	DC 3.6 V to 14 V	DC 4.75 V to 30 V
Power consumption (max.)	3.6 V: ≤ 0.6 W 14 V: ≤ 0.7 W	5 V: ≤ 0.8 W 10 V: ≤ 0.65 W 30 V: ≤ 1 W		3.6 V: ≤ 0.7 W 14 V: ≤ 0.8 W	5 V: ≤ 0.95 W 10 V: ≤ 0.75 W 30 V: ≤ 1.1 W	
Current consumption (typical, without load)	5 V: 85 mA	5 V: 90 mA 24 V: 24 mA		5 V: 105 mA	5 V: 120 mA 24 V: 28 mA	
Shaft	Solid shaft Ø 10 mm					
Mech. permiss. shaft speed n	≤ 15000 rpm			≤ 12000 rpm		
Starting torque (typical)	0.01 Nm (at 20 °C)					
Moment of inertia of rotor	≤ 2.3 · 10 ⁻⁶ kgm ²					
Shaft load	<i>Axial:</i> ≤ 40 N; <i>radial:</i> ≤ 60 N at shaft end (see also <i>Mechanical design types and mounting</i>)					
Vibration 55 Hz to 2000 Hz Shock 6 ms	≤ 300 m/s ² ; (EN 60068-2-6); higher values upon request <i>ROC/ROQ:</i> ≤ 2000 m/s ² ; <i>RIC/RIQ:</i> ≤ 1000 m/s ² (EN 60068-2-27)					
Max. operating temp. ³⁾	100 °C					
Min. operating temp.	<i>Flange socket or fixed cable:</i> –40 °C; <i>moving cable:</i> –10 °C					
Protection EN 60529	IP67 at housing; IP64 at shaft inlet (IP66 upon request)					
Mass	≈ 0.35 kg					
Valid for ID	683640-xx ⁴⁾ / 1322269-xx ^{4) 5)}	1109255-xx	1131751-xx / 1353114-xx ⁵⁾	683642-xx ⁴⁾ / 1322274-xx ^{4) 5)}	1109257-xx	1131753-xx / 1353118-xx ⁵⁾

Bold: This preferred version is available on short notice.

* Please select when ordering

¹⁾ Speed-dependent deviations between absolute value and incremental signal

²⁾ Limited tolerances: signal amplitude: 0.8 V_{PP} to 1.2 V_{PP}

³⁾ For the relationship of operating temperature to shaft speed and supply voltage, see *General mechanical information*

⁴⁾ Also available with functional safety; for dimensions and specifications, see Product Information document

⁵⁾ Successor variant

ROC/ROQ 400F/S series

Absolute rotary encoders

- Clamping flange with additional slot for fastening with fixing clamps
- Solid shaft for separate shaft coupling
- Fanuc Serial Interface or Siemens DRIVE-CLiQ interface



ROC/ROQ 400F/M

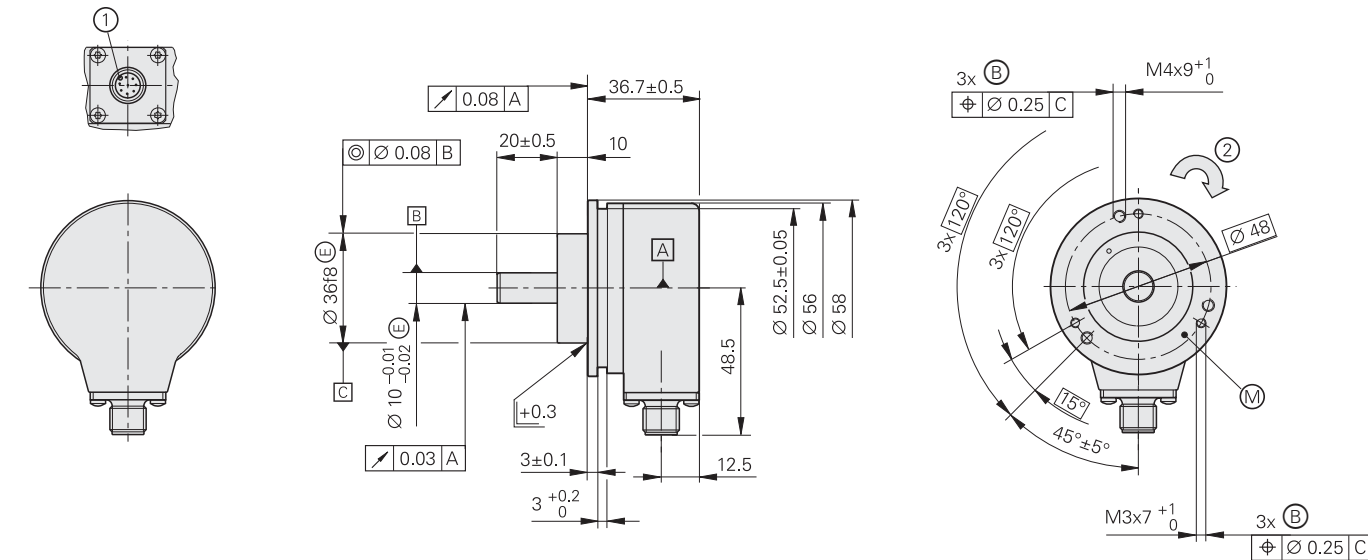

ROC/ROQ 400S

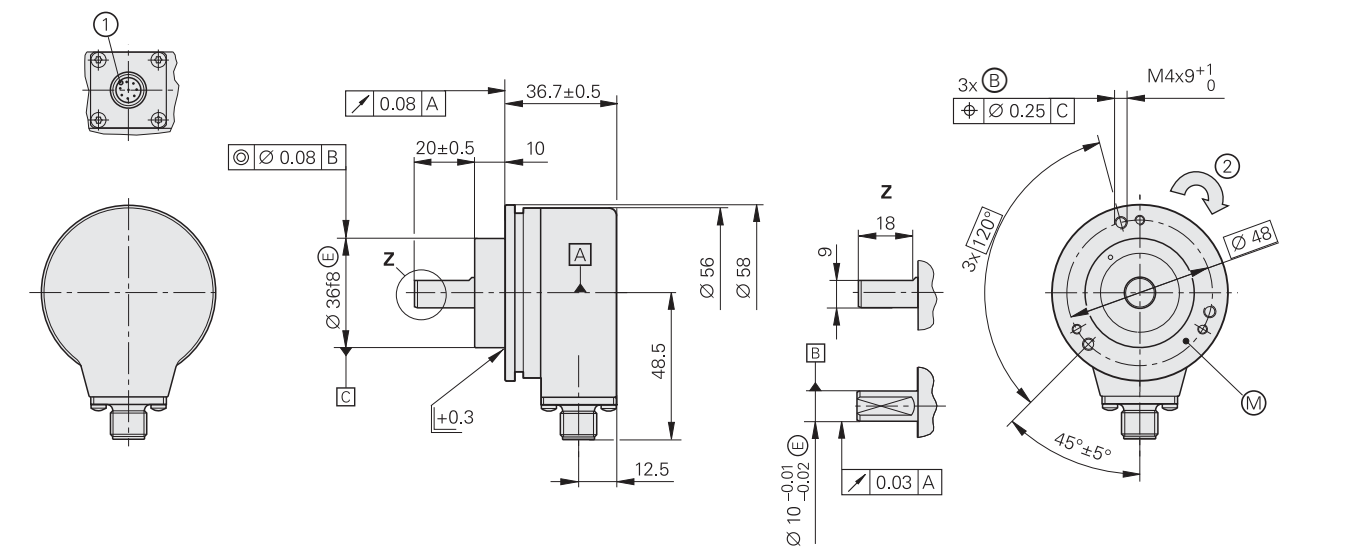

mm
 Tolerancing ISO 8015
 ISO 2768 - m H
 < 6 mm: ±0.2 mm

- ▣ = Bearing
- ⊙ = Fastening thread
- ⊙ = Measuring point for operating temperature
- 1 = Connector coding
- 2 = Direction of shaft rotation for output signals as per the interface description

DRIVE-CLiQ is a registered trademark of Siemens AG.

	Absolute		Multiturn	
	Singleturn	ROC 424S	ROQ 437F	ROQ 436S
Interface	Fanuc Serial Interface; αi Interface	DRIVE-CLiQ	Fanuc Serial Interface; αi Interface	DRIVE-CLiQ
Ordering designation	Fanuc05 ¹⁾	DQ01	Fanuc06 ¹⁾	DQ01
Positions per revolution	αi: 33554432 (25 bits) α: 8388608 (23 bits)	16777216 (24 bits)	33554432 (25 bits)	16777216
Revolutions	8192 via revolution counter	–	αi: 4096	4096
Code	Pure binary			
Elec. perm. shaft speed	≤ 15000 rpm for continuous position value			
Calculation time t_{cal}	≤ 5 μs	≤ 8 μs ²⁾	≤ 5 μs	≤ 8 μs ²⁾
System accuracy	±20"			
Electrical connection	M12 flange socket, radial			
Cable length	≤ 30 m	≤ 95 m ³⁾	≤ 30 m	≤ 95 m ³⁾
DC supply voltage	3.6 V to 14 V	10 V to 36 V	3.6 V to 14 V	10 V to 36 V
Power consumption (max.)	5 V: ≤ 0.7 W 14 V: ≤ 0.8 W	10 V: ≤ 1.4 W 36 V: ≤ 1.5 W	5 V: ≤ 0.75 W 14 V: ≤ 0.85 W	10 V: ≤ 1.4 W 36 V: ≤ 1.5 W
Current consumption (typical, without load)	5 V: 90 mA	24 V: 37 mA	5 V: 100 mA	24 V: 43 mA
Shaft	Solid shaft Ø 10 mm (for ROC 424 S and ROQ 436 S with flat)			
Mech. perm. shaft speed $n^4)$	≤ 15000 rpm		≤ 12000 rpm	
Starting torque (typical)	0.01 Nm (at 20 °C)			
Moment of inertia of rotor	≤ 2.9 · 10 ⁻⁶ kgm ²			
Shaft load	Axial: 40 N; radial: 60 N at shaft end (see also <i>Mechanical design types and mounting</i>)			
Vibration 55 Hz to 2000 Hz Shock 6 ms	≤ 300 m/s ² (EN 60068-2-6) ≤ 2000 m/s ² (EN 60068-2-27)			
Max. operating temp. ⁴⁾	100 °C			
Min. operating temp.	-30 °C			
Protection EN 60529	IP67 at housing; IP64 at shaft inlet			
Mass	≈ 0.35 kg			
Valid for ID	1081306-xx	1036790-xx ⁵⁾	1081304-xx	1036792-xx ⁵⁾

1) Optimized for Fanuc machine tools
 2) Calculation time TIME_MAX_ACTVAL
 3) See the *Interfaces of HEIDENHAIN Encoders* brochure; with $n_{EN} = 1$ (including adapter cable)
 4) For the relationship of operating temperature to shaft speed and supply voltage, see *General mechanical information*
 5) Also available with functional safety; for dimensions and specifications, see Product Information document

ROD 600 series

- Incremental rotary encoders with sturdy design
- Clamping flange
- Solid shaft for separate shaft coupling

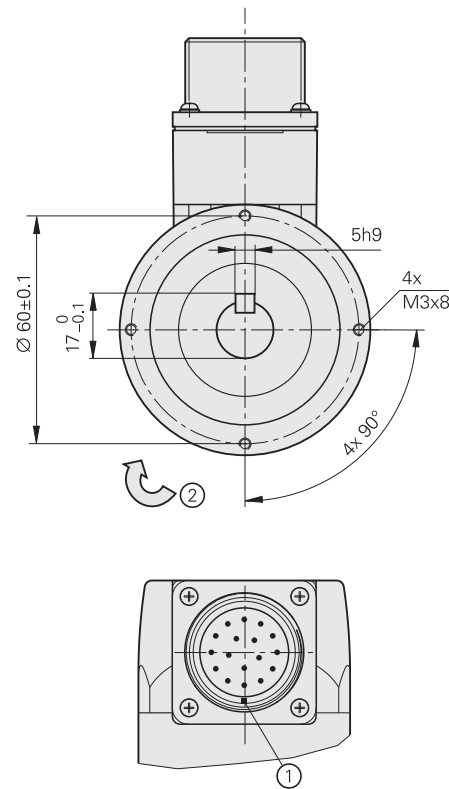
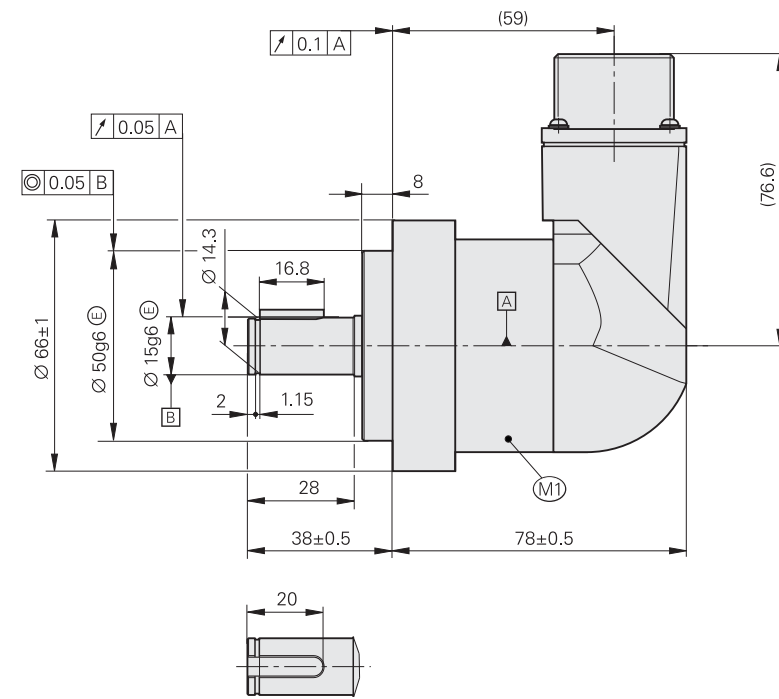

mm

 Tolerancing ISO 8015
 ISO 2768 - m H
 < 6 mm: ±0.2 mm

- ▣ = Encoder bearing
- M1 = Measuring point for operating temperature
- 1 = Connector polarizing key
- 2 = Direction of shaft rotation for output signals as per the interface description

	Incremental	
	ROD 620	ROD 630
Incremental signals		
Line counts*	512 1000 1024 2048 5000	
Reference mark	One	
Scanning frequency Edge separation <i>a</i>	≤ 300 kHz ≥ 0.39 μs	
System accuracy	±1/20 of grating period	
Electrical connection	17-pin flange socket 1 ¼" – 18UNEF, radial ²⁾	
Supply voltage Current consumption without load	DC 5 V ±0.5 V ≤ 120 mA	DC 10 V to 30 V ≤ 150 mA
Shaft	Solid shaft Ø 15 mm with key	
Mech. perm. shaft speed <i>n</i>	≤ 12000 rpm	
Starting torque (typical)	0.05 Nm (at 20 °C)	
Moment of inertia of rotor	≤ 11 · 10 ⁻⁶ kgm ²	
Shaft load	Axial: 75 N Radial: 75 N at shaft end	
Vibration 55 Hz to 2000 Hz Shock 6 ms	≤ 200 m/s ² (EN 60068-2-6) ≤ 2000 m/s ² (EN 60068-2-27)	
Max. operating temp. ¹⁾	85 °C	
Min. operating temp.	-20 °C	
Relative humidity	≤ 93 % (40 °C/4 d as per EN 60068-2-78); without condensation	
Protection EN 60529	IP66	
Mass	≈ 0.8 kg	
Valid for ID	1145260-xx	1145261-xx

* Please select when ordering
 1) Self-heating during operation of the rotary encoder at room temperature and shaft speed of 6000 rpm: approx. +50 K
 2) Compatible mating connector: ID 1094831-01; cable only: ID 816317-xx

ROD 1930

Incremental rotary encoders

- For fastening with flange or base
- Solid shaft with key for separate shaft coupling



Solid shaft

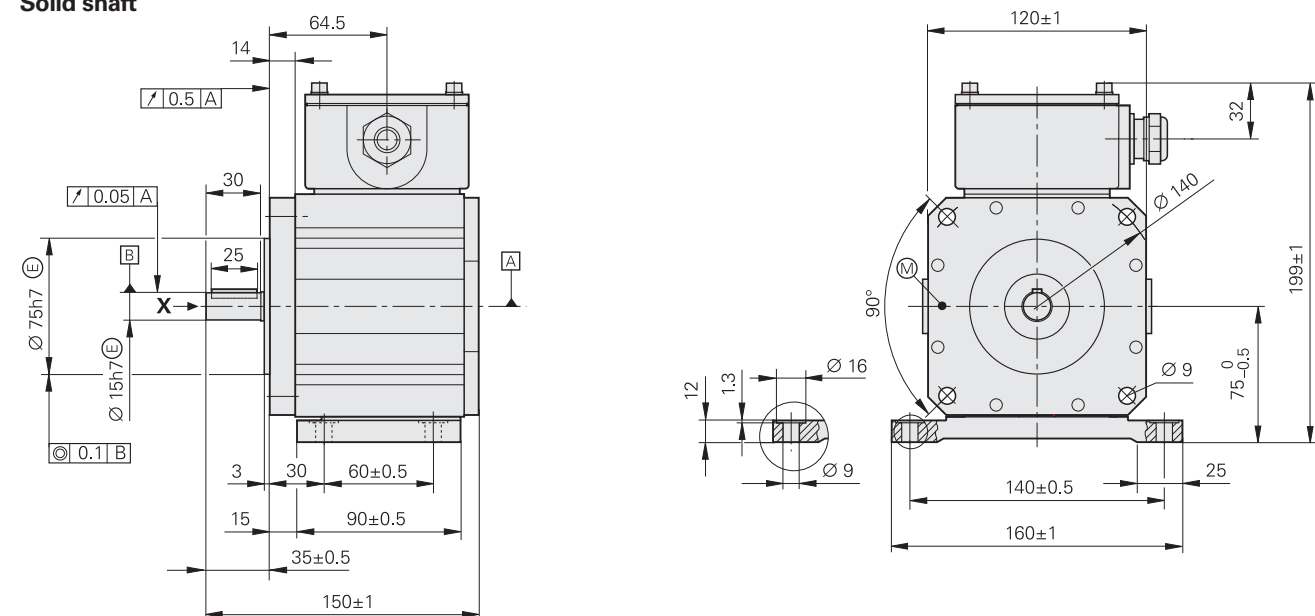

Solid through shaft

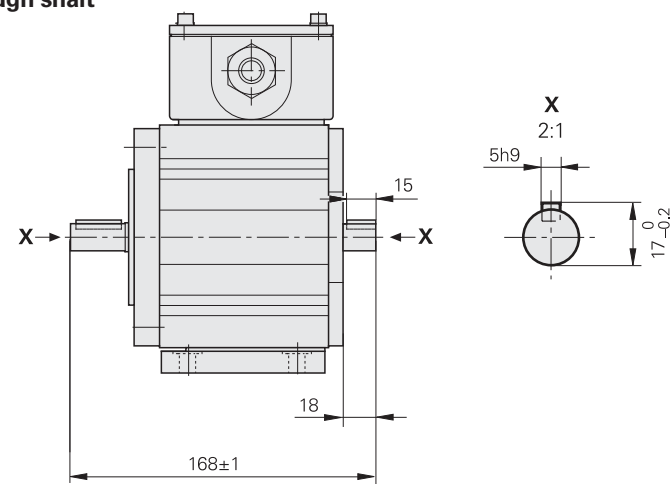

mm

 Tolerancing ISO 8015
 ISO 2768 - m H
 < 6 mm: ±0.2 mm

= Bearing
 = Measuring point for operating temperature

Incremental	
ROD 1930	
Interface*	HTL HTLs
Line counts*	600 1024 1200 2400
Reference mark	- One
Output frequency Edge separation <i>a</i>	≤ 160 kHz ≤ 0.76 μs
System accuracy	±1/10 of grating period
Electrical connection	Terminal box with screw terminals
Supply voltage	DC 10 V to 30 V
Current consumption (typical, without load)	15 V: 60 mA
Shaft*	Solid shaft or solid through shaft Ø 15 mm with key
Mech. permiss. shaft speed	≤ 4000 rpm
Starting torque (typical) at 20 °C	Solid shaft: 0.05 Nm Solid through shaft: 0.15 Nm
Moment of inertia of rotor	$2.5 \cdot 10^{-5} \text{ kgm}^2$
Permissible angular acceleration	$\leq 4 \cdot 10^4 \text{ rad/s}^2$
Shaft load ¹⁾	Axial: ≤ 150 N Radial: ≤ 200 N at shaft end
Vibration 25 Hz to 200 Hz Shock 6 ms	≤ 100 m/s ² (EN 60068-2-6) ≤ 1000 m/s ² (EN 60068-2-27)
Operating temperature ²⁾	-20 °C to +70 °C
Protection EN 60529	IP66
Mass	≈ 4.5 kg
Valid for ID	Solid shaft: 1043373-xx Through shaft: 1043377-xx

* Please select when ordering

¹⁾ See also *Mechanical design types and mounting*

²⁾ Special versions upon request (e.g., with water jacket)

HR 1120

Electronic handwheel

- Version for integration
- With mechanical detent

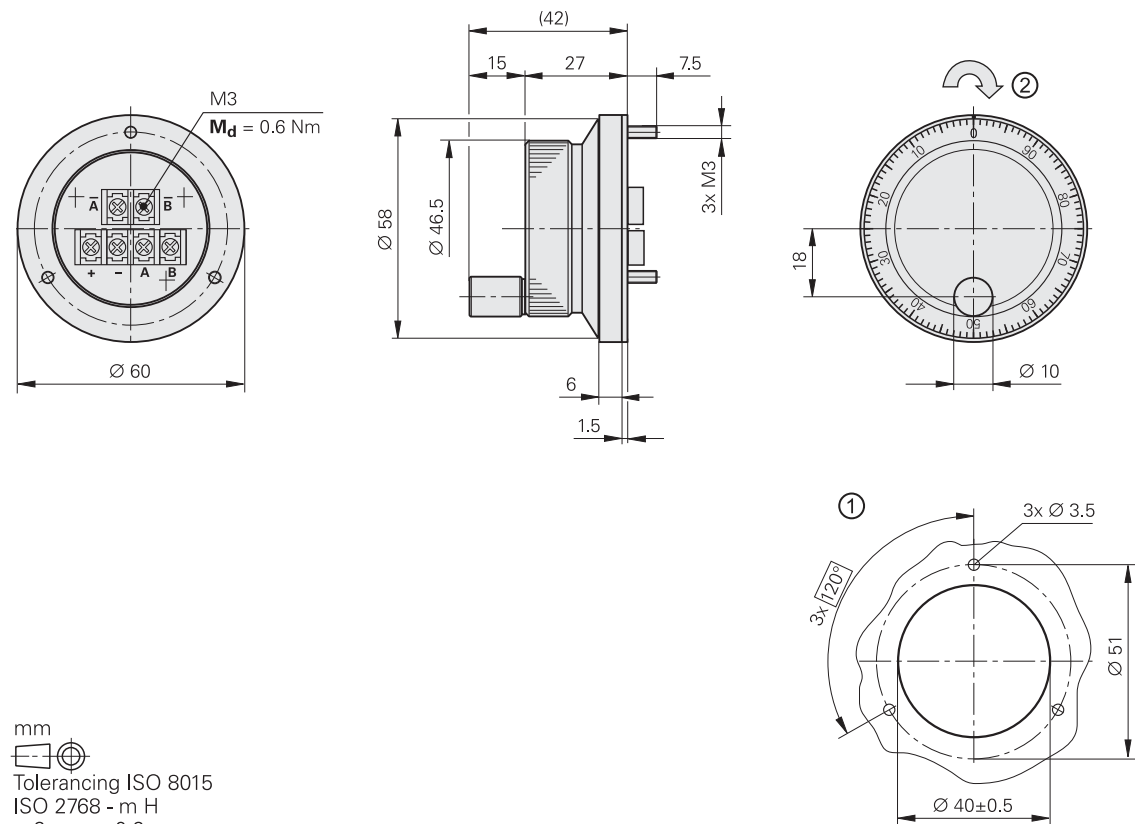

mm
 Tolerancing ISO 8015
 ISO 2768 - m H
 < 6 mm: ±0.2 mm

1 = Cutout for mounting
 2 = Direction for output signals as per the interface description

Incremental	
HR 1120	
Interface	TTL
Line count	100
Output frequency	≤ 5 kHz
Switching times	t ₊ / t ₋ ≤ 100 ns
Electrical connection	Via M3 screw terminals
Cable length	≤ 30 m
Supply voltage	DC 5 V ±0.25 V
Current consumption without load	≤ 160 mA
Detent	Mechanical 100 detent positions per revolution Detent positions defined within the LOW level of U _{a1} and U _{a2}
Mech. perm. shaft speed	≤ 200 rpm
Torque	≤ 0.1 Nm (at 25 °C)
Vibration (10 Hz to 200 Hz)	≤ 20 m/s ²
Max. operating temp.	60 °C
Min. operating temp.	0 °C
Protection EN 60529	IP00; IP40 when mounted No condensation permitted
Mass	≈ 0.15 kg
Valid for ID	687617-xx

Interfaces

~ 1 V_{PP} incremental signals

HEIDENHAIN encoders with the ~ 1 V_{PP} interface provide voltage signals that can be highly interpolated.

The sinusoidal **incremental signals** A and B are phase-shifted by 90° elec. and have a typical amplitude of 1 V_{PP}. The illustrated sequence of output signals—with B lagging A—applies to the direction of motion shown in the dimension drawing.

The **reference mark signal** R has a unique assignment to the incremental signals. The output signal may be lower next to the reference mark.

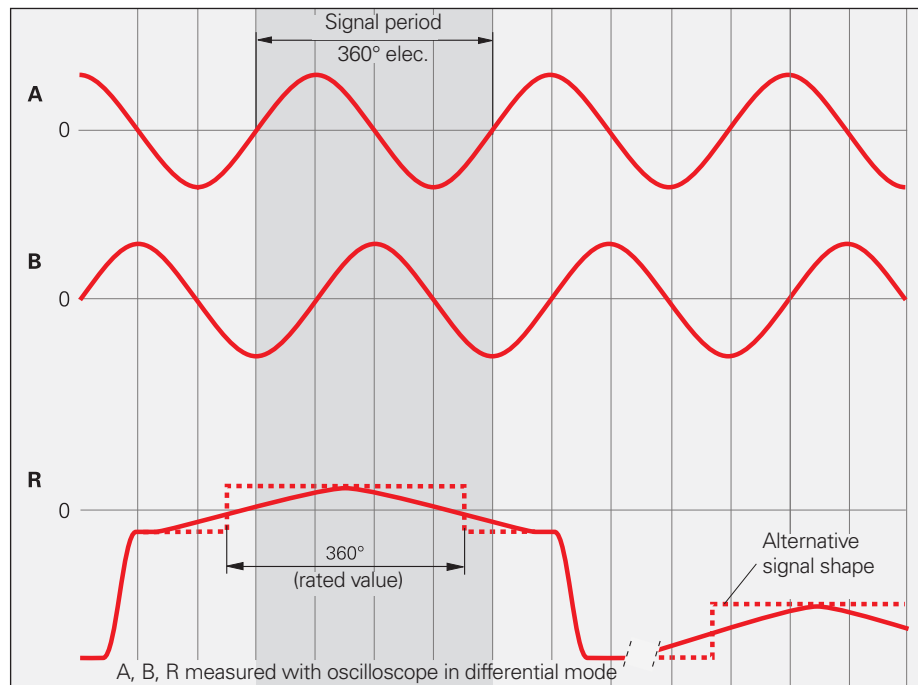

Further information:

For detailed descriptions of all available interfaces, as well as general electrical information, please refer to the *Interfaces of HEIDENHAIN Encoders* brochure.

HEIDENHAIN offers signal converters for adapting encoders to the interface of the downstream electronics. For information about this, please refer to the *Signal Converters* Product Overview.

Pin layout

12-pin M23 coupling		12-pin M23 connector		Power supply						Incremental signals						Other signals			
				12	2	10	11	5	6	8	1	3	4	9	7	/			
		U _P	Sensor ¹⁾ U _P	0V	Sensor ¹⁾ 0V	A+	A-	B+	B-	R+	R-	Vacant	Vacant	Vacant					
		Brown/ Green	Blue	White/ Green	White	Brown	Green	Gray	Pink	Red	Black	/	Violet	Yellow					

Cable shield connected to housing; U_P = Power supply voltage

Sensor: The sense line is connected in the encoder with the corresponding power line. Vacant pins or wires must not be used!

¹⁾ LIDA 2xx: vacant

□ TTL incremental signals

HEIDENHAIN encoders with the □ TTL interface incorporate electronics that digitize sinusoidal scanning signals with or without interpolation.

The **incremental signals** are output as the square-wave pulse trains U_{a1} and U_{a2}, phase-shifted by 90° elec. The **reference mark signal** consists of one or more reference pulses U_{a0}, which are gated with the incremental signals. In addition, the integrated electronics generate the **inverted signals** U_{a1}⁻, U_{a2}⁻, and U_{a0}⁻ for noise-immune transmission. The illustrated sequence of output signals—with U_{a2} lagging U_{a1}—applies to the direction of motion shown in the dimension drawing.

The **fault detection signal** U_{aS}⁻ indicates malfunctions such as supply line breakage, failure of the light source, etc.

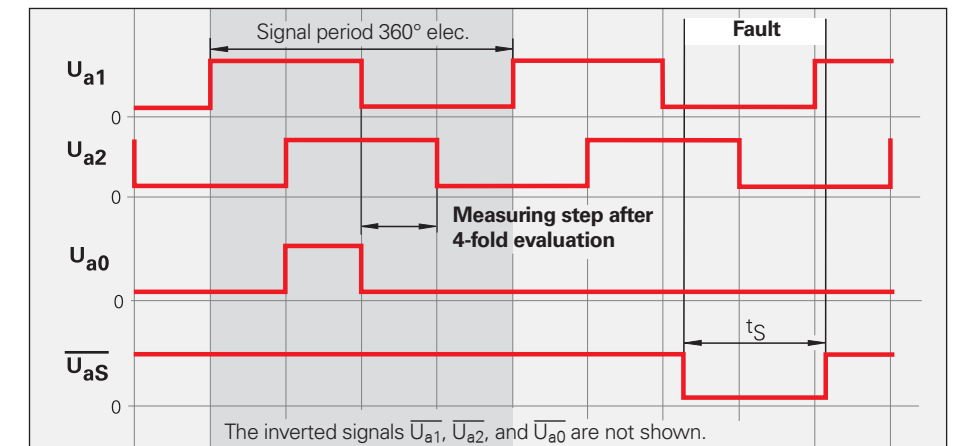

The distance between two successive edges of the incremental signals U_{a1} and U_{a2} through 1-fold, 2-fold, or 4-fold evaluation is one **measuring step**.

Further information:

For detailed descriptions of all available interfaces, as well as general electrical information, please refer to the *Interfaces of HEIDENHAIN Encoders* brochure.

ERN and ROD pin layouts

12-pin M23 flange socket or coupling		12-pin M23 connector		17-pin flange socket 1¼" – 18UNEF											
		Power supply				Incremental signals				Other signals					
		12	2	10	11	5	6	8	1	3	4	7	9		
		H	F	K	M	A	N	C	R	B	P	S	D/E/G/J/L/T		
		U _P	Sensor U _P	0V	Sensor 0V	U _{a1}	U _{a1} ⁻	U _{a2}	U _{a2} ⁻	U _{a0}	U _{a0} ⁻	U _{aS} ¹⁾	Vacant ²⁾		
		Brown/ Green	Blue	White/ Green	White	Brown	Green	Gray	Pink	Red	Black	Violet	Yellow		

Shield on housing; U_P = Power supply voltage

Sensor: The sense line is connected in the encoder with the corresponding power line.

¹⁾ ERO 14xx: vacant

²⁾ Exposed linear encoders: TTL/11 μA_{PP} switchover for PWT

HR pin layout

Screw-terminal connection		Power supply		Incremental signals			
		+	-	A	A ⁻	B	B ⁻
Signal		U _P 5V	U _N 0V	U _{a1}	U _{a1} ⁻	U _{a2}	U _{a2} ⁻

A shielded cable with a cross section of at least 0.5 mm² is recommended when connecting the handwheel to the power supply. The handwheel is connected via screw terminals. The wires must be provided with the appropriate ferrules.

HTL, HTLs incremental signals

HEIDENHAIN encoders with the HTL interface contain electronics that digitize sinusoidal scanning signals with or without interpolation.

The **incremental signals** are output as the square-wave pulse trains U_{a1} and U_{a2} , phase-shifted by 90° elec. The **reference mark signal** consists of one or more reference pulses U_{a0} , which are gated with the incremental signals. In addition, the integrated electronics generate the **inverted signals** $\overline{U_{a1}}$, $\overline{U_{a2}}$, and $\overline{U_{a0}}$ for noise-immune transmission (not with HTLs). The illustrated sequence of output signals—with U_{a2} lagging U_{a1} —applies to the direction of motion shown in the dimension drawing.

The **fault detection signal** $\overline{U_{aS}}$ indicates a malfunction such as failure of the light source, etc.

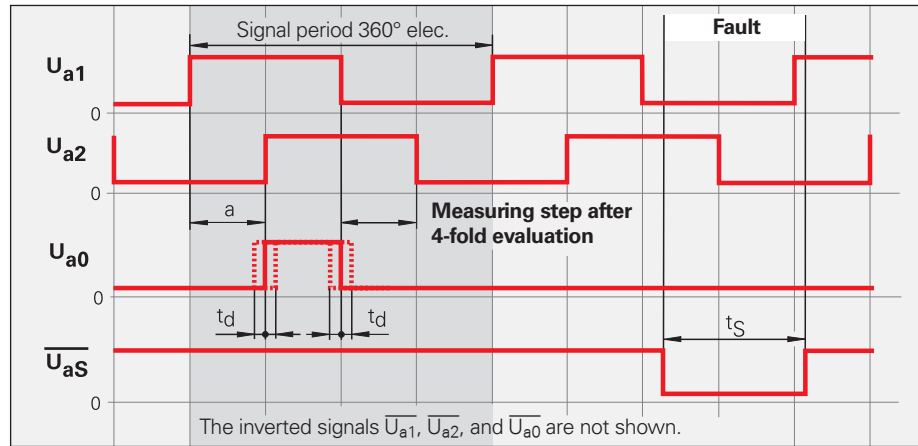

The distance between two successive edges of the incremental signals U_{a1} and U_{a2} through 1-fold, 2-fold, or 4-fold evaluation is one **measuring step**.

Further information:
For detailed descriptions of all available interfaces, as well as general electrical information, please refer to the *Interfaces of HEIDENHAIN Encoders* brochure.

Power and current consumption

For encoders with a wide supply voltage range, the current consumption exhibits a nonlinear relationship to the supply voltage. It is determined using the calculation described in the *Interfaces of HEIDENHAIN Encoders* brochure.

For the rotary encoders with additional HTL output signals, the power consumption also depends on the output frequency and cable length. The power consumption values for the HTL and HTLs interfaces can therefore be read off separately from the diagrams.

The maximum permissible output frequency is shown in the specifications. This frequency occurs at the maximum permissible shaft speed. The output frequency for any shaft speed is calculated using the following formula:

$$f = (n/60) \cdot z \cdot 10^{-3}$$

With
 f = Output frequency in kHz
 n = Shaft speed in rpm
 z = Number of signal periods per 360°

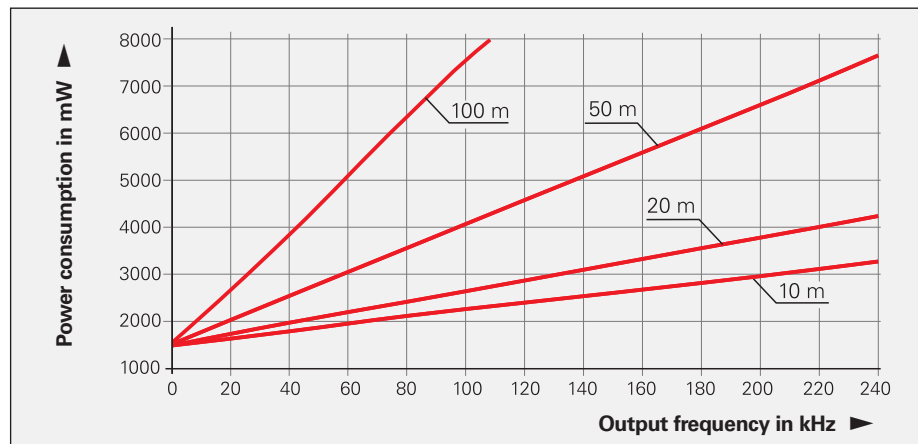

Power consumption (maximum) for the HTL interface and supply voltage $U_P = 30V$

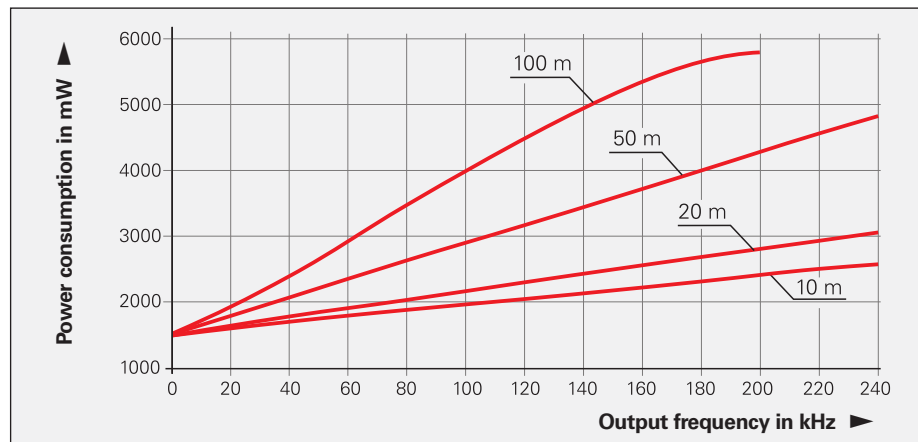

Power consumption (maximum) for the HTLs interface and supply voltage $U_P = 30V$

Cable length for HTL

For those rotary encoders with additional HTL output signals, the maximum permissible cable length may vary depending on several criteria:

- Output frequency
- Supply voltage
- Operating temperature

The diagrams show these relationships separately for the HTL and HTLs interfaces. At a supply voltage of DC 10V, there are no limitations on cable length.

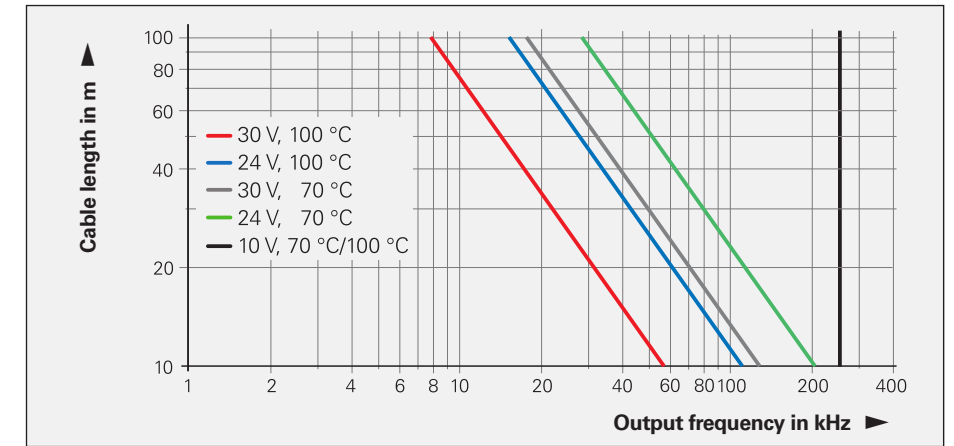

Maximum permissible cable length for the HTL interface

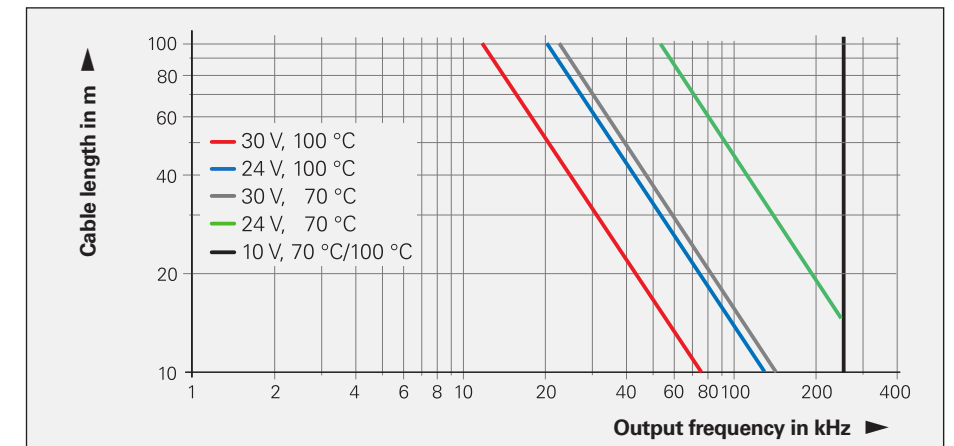

Maximum permissible cable length for the HTLs interface

EnDat position values

Pin layout

12-pin M23 flange socket or coupling				17-pin flange socket 1 1/4" - 18UNEF								
	Power supply			Incremental signals				Other signals				
M23	12	2	10	11	5	6	8	1	3	4	7	9
1 1/4"	H	F	K	M	A	N	C	R	B	P	S	D/E/G/J/L/T
HTL	U _P	Sensor U _P	0V	Sensor 0V	U _{a1}	U _{a1}	U _{a2}	U _{a2}	U _{a0}	U _{a0}	U _{aS}	Vacant
HTLs*	—		—		0V		0V		0V			
	Brown/Green	Blue	White/Green	White	Brown	Green	Gray	Pink	Red	Black	Violet	Yellow

Shield on housing; U_P = Power supply voltage

Sensor: The sense line is connected in the encoder with the corresponding power line.

* Only with 12-pin M23 flange socket or coupling

ROD 1930 pin layout

Screw-terminal connection						
	1	2	3	4	5	6
	Power supply		Incremental signals			
Connection	1	2	3	4	5	6
HTL	U _P	U _N 0V	U _{a1}	U _{a1}	U _{a2}	U _{a2}
HTLs			U _{a2}	0V	U _{a0}	

For connection, a shielded cable with a cross section of at least 0.5 mm² is recommended for the power supply. The connection is performed via screw terminals. The wires must be provided with the appropriate ferrules.

The EnDat interface is a digital, **bidirectional** interface for encoders. It is capable of outputting **position values**, reading information stored in the encoder, updating this information, and storing new information. Because the interface uses **serial transmission**, only **four signal lines** are required. The data (DATA) are transmitted in **synchronism** with the CLOCK signal from the downstream electronics. The type of transmission (position values, parameters, diagnostics, etc.) is selected via mode commands that the downstream electronics send to the encoder. Some functions are available only with EnDat 2.2 mode commands.

Further information:

For detailed descriptions of all available interfaces, as well as general electrical information, please refer to the *Interfaces of HEIDENHAIN Encoders* brochure.

Integrated temperature evaluation

Rotary encoders with EnDat 2.2 feature an internal temperature sensor integrated into the encoder electronics. The digitized temperature value is transmitted purely serially via the EnDat protocol. Please bear in mind that this temperature measurement and transmission is not safe in terms of functional safety.

With regard to the internal temperature sensor, these rotary encoders support the two-stage cascaded signaling of a temperature exceedance. This signaling consists of an EnDat warning and an EnDat error message.

In compliance with the EnDat specification, when the temperature reaches the warning threshold for the temperature exceedance of the internal temperature sensor, an EnDat warning is issued (EnDat memory area "Operating status," word 1 "Warnings," bit 2¹ "Temperature exceeded").

Ordering designation	Command set	Incremental signals
EnDat01 EnDatH EnDatT	EnDat 2.1 or EnDat 2.2	1 V _{PP} HTL TTL
EnDat21		—
EnDat02	EnDat 2.2	1 V _{PP}
EnDat22	EnDat 2.2	—

Versions of the EnDat interface

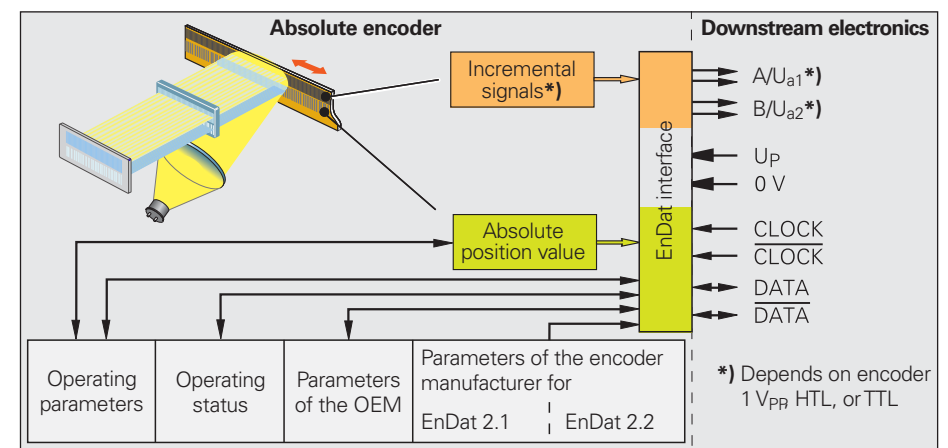

This warning threshold for the internal temperature sensor is stored in the EnDat memory area "Operating parameters," word 6 "Trigger threshold warning bit for excessive temperature," and can be individually adjusted. A device-specific default value is saved here before shipping. The temperature measured by the internal temperature sensor is higher by a device-specific and application-specific amount than the temperature at measuring point M1 in accordance with the dimension drawing.

The encoders feature a further, albeit non-adjustable, trigger threshold of the internal temperature sensor, which, when exceeded, triggers an EnDat error message (the EnDat memory area "Operating status," word 0 "Error messages," bit 2² "Position," and in additional data 2 "Operating status error sources," bit 2⁶ "Temperature exceeded"). This threshold may vary depending on the encoder and is stated in the specifications.



HEIDENHAIN recommends adjusting the warning threshold based on the application such that this threshold is sufficiently below the trigger threshold for the "Temperature exceeded" EnDat error message. Compliance with the operating temperature at measuring point M1 is required for adherence to the encoder's proper and intended use.

Fanuc pin layouts

Pin layout

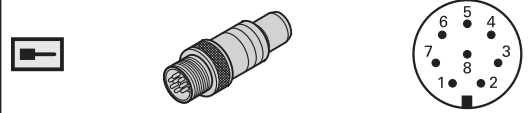
8-pin M12 coupling





	Power supply				Serial data transmission			
	8	2	5	1	3	4	7	6
	U _P	Sensor U _P	0V	Sensor 0V	DATA	DATA	CLOCK	CLOCK
	Brown/Green	Blue	White/Green	White	Gray	Pink	Violet	Yellow

Cable shield connected to housing; **U_P** = Power supply voltage

Sensor: The sense line is connected in the encoder with the corresponding power line.
Vacant pins or wires must not be used!

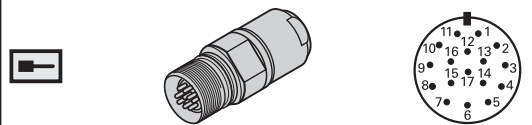
17-pin M23 coupling



	Power supply					Incremental signals ¹⁾				Serial data transmission			
	7	1	10	4	11	15	16	12	13	14	17	8	9
	U _P	Sensor U _P	0V	Sensor 0V	Internal shield ²⁾	A+	A-	B+	B-	DATA	DATA	CLOCK	CLOCK
	Brown/Green	Blue	White/Green	White	/	Green/Black	Yellow/Black	Blue/Black	Red/Black	Gray	Pink	Violet	Yellow

Cable shield connected to housing; **U_P** = Power supply voltage

Sensor: The sense line is connected in the encoder with the corresponding power line.
Vacant pins or wires must not be used!

¹⁾ Only with EnDat01 and EnDat02

²⁾ Vacant for the ECN/EQN 10xx and ROC/ROQ 10xx

Fanuc pin layout

HEIDENHAIN encoders with the code letter F after the model designation are optimized for connection to Fanuc machine-tool controls with the

Fanuc Serial Interface – α Interface

- Ordering designation: Fanuc02 normal and high speed, two-pair transmission

Fanuc Serial Interface – α Interface

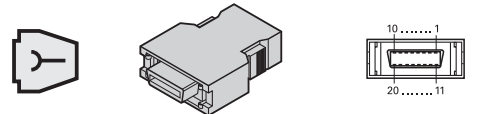

- Ordering designation: Fanuc05 high speed, one-pair transmission
Incorporates the α Interface (normal and high speed, two-pair transmission)
- Ordering designation: Fanuc06 high speed, one-pair transmission

20-pin Fanuc connector

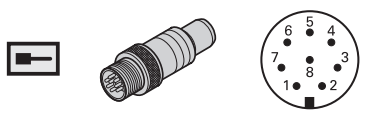

8-pin M12 coupling



	Power supply					Serial data transmission			
	9	18/20	12	14	16	1	2	5	6
	8	2	5	1	-	3	4	7	6
	U _P	Sensor U _P	0V	Sensor 0V	Shield	Serial Data	Serial Data	Request	Request
	Brown/Green	Blue	White/Green	White	-	Gray	Pink	Violet	Yellow

Cable shield connected to housing; **U_P** = Power supply voltage

Sensor: The sense line is connected in the encoder with the corresponding power line.
Vacant pins or wires must not be used!

Siemens pin layout

Siemens pin layout

HEIDENHAIN encoders with the code letter S after the model designation are suitable for connection to Siemens controls with the **DRIVE-CLiQ interface**

- Ordering designation: DQ01

RJ45 connector	Power supply		Serial data transmission			
	A	B	Transmit data		Receive data	
	1	5	3	6	1	2
	1	5	7	6	3	4
	U _P	0V	TXP	TXN	RXP	RXN

Cable shield connected to housing; U_P = Power supply voltage

Integrated temperature evaluation

Rotary encoders with the DRIVE-CLiQ interface include an internal temperature sensor integrated into the encoder electronics. The digitized temperature value is transmitted purely serially via the DRIVE-CLiQ interface. Please bear in mind that neither the temperature measurement nor the transmission of the temperature value is safe in terms of functional safety.

The temperature measured by the internal temperature sensor is higher by a device-specific and application-specific amount than the temperature at measuring point M1 in accordance with the dimension drawing.

Upon reaching a trigger threshold for the internal temperature sensor, these rotary encoders issue an "Alarm 405" error message. This threshold may vary

depending on the encoder and is stated in the specifications. During operation, HEIDENHAIN recommends keeping the temperature adequately below the trigger threshold for the error message.

Compliance with the operating temperature at measuring point M1 is required for adherence to the encoder's proper and intended use.

SSI position values

The **position value** is transmitted, starting with the most significant bit (MSB), over the data lines (DATA) in synchronism with a clock signal (CLOCK) provided by the control. The SSI standard data word length for singleturn encoders is 13 bits, and for multiturn encoders, 25 bits. In addition to the absolute position values, **incremental signals** can be transmitted as well. For a signal description, see 1 V_{PP} incremental signals.

The following **functions** can be activated via programming inputs:

- Direction of rotation**
- Zero reset** (setting to zero)

Data transmission

T = 1 to 10 μs
 t_{cal} See Specifications
 t₁ ≤ 0.4 μs (without cable)
 t₂ = 17 μs to 20 μs
 t_R ≥ 5 μs
 n = Data word length
 13 bits for ECN/ROC
 25 bits for EQN/ROQ

CLOCK and DATA not shown

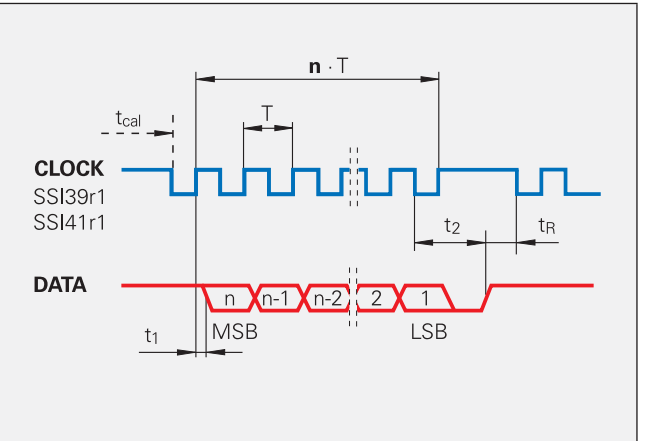

Pin layout

17-pin M23 coupling	Power supply				Incremental signals				Serial data transmission				Other signals		
	7	1	10	4	11	15	16	12	13	14	17	8	9	2	5
	U _P	Sensor U _P	0V	Sensor 0V	Internal shield	A+	A-	B+	B-	DATA	DATA	CLOCK	CLOCK	Dir. of rotation	Set to zero
	Brown/ Green	Blue	White/ Green	White	/	Green/ Black	Yellow/ Black	Blue/ Black	Red/ Black	Gray	Pink	Violet	Yellow	Black	Green

Shield on housing; U_P = Power supply voltage

Sensor: With a 5 V supply voltage, the sense line is connected in the encoder with the corresponding power line. Vacant pins or wires must not be used!

DRIVE-CLiQ is a registered trademark of Siemens AG.

Further information:

For detailed descriptions of all available interfaces, as well as general electrical information, please refer to the *Interfaces of HEIDENHAIN Encoders* brochure.

Cables and connecting elements

General information

Plastic-insulated connector: connecting element with coupling ring, available with male or female contacts (see symbols)

Symbols

M12

M12 right-angle connector

M23

1/4" - 18UNEF

D-sub connector for HEIDENHAIN controls and evaluation electronics.

Symbols

¹⁾ Interface electronics integrated into the connector

Plastic-insulated coupling: connecting element with external thread, available with male or female contacts (see symbols)

Symbols



Mounted coupling with central fastening

Mounted coupling with flange

Flange socket with external thread; is permanently mounted on a housing, available with male or female contacts

Symbols

The **pin numbering** on connectors is in the direction opposite to that on couplings or flange sockets, regardless of whether the connecting elements have

male contacts or  female contacts. 

When connected, the connecting elements provide are **rated** at IP67 (D-sub connector: IP50; EN 60529). When not connected, there is no protection.

Accessory for flange sockets and M23 mounted couplings

Threaded metal dust cap
ID 219926-01

Accessory for M12 connecting element
Insulation spacer
ID 596495-01

Connecting cables for 1 V_{PP}, TTL, HTL

12-pin M23

		~ 1 V _{PP} □ TTL, □ HTL
PUR connecting cables	12-pin: 4(2 x 0.14 mm ²) + (4 x 0.5 mm ²); A _P = 0.5 mm ²	Ø 8 mm
With connector (female) and coupling (male)		298401-xx
With connector (female) and connector (male)		298399-xx
With connector (female) and 15-pin D-sub connector (female) for the TNC		310199-xx
With connector (female) and 15-pin D-sub connector (male) for the PWM 20/EIB 74x		310196-xx
With connector (female) and stripped cable end		309777-xx
Cable only, Ø 8 mm		816317-xx
Mating element on connecting cable; fits encoder connector	Connector (female) for cable Ø 8 mm	291697-05
Connector on connecting cable for connection to the downstream electronics	Connector (male) for cable Ø 8 mm Ø 6 mm	291697-08 291697-07
Coupling on connecting cable	Coupling (male) for cable Ø 4.5 mm Ø 6 mm Ø 8 mm	291698-14 291698-03 291698-04
Flange socket for installation the downstream electronics	Flange socket (female)	315892-08
Mounted couplings	With flange (female) Ø 6 mm Ø 8 mm	291698-17 291698-07
	With flange (male) Ø 6 mm Ø 8 mm	291698-08 291698-31
	With central fastening (male) Ø 6 mm to 10 mm	741045-01
Adapter connector ~ 1 V _{PP} /11 μA _{PP} For converting 1 V _{PP} to 11 μA _{PP} ; 12-pin M23 connector (female) and 9-pin M23 connector (male)		364914-01

A_P: Cross section of power supply lines

EnDat connecting cables

8-pin M12 17-pin M23

		EnDat without incremental signals		EnDat with incremental signals SSI
PUR connecting cables		8-pin: $(4 \times 0.14 \text{ mm}^2) + (4 \times 0.34 \text{ mm}^2)$; $A_P = 0.34 \text{ mm}^2$ 17-pin: $(4 \times 0.14 \text{ mm}^2) + 4(2 \times 0.14 \text{ mm}^2) + (4 \times 0.5 \text{ mm}^2)$; $A_P = 0.5 \text{ mm}^2$		
	Cable diameter	6 mm	3.7 mm	8 mm
With connector (female) and coupling (male)		368330-xx	801142-xx	323897-xx 340302-xx
With right-angle connector (female) and coupling (male)		373289-xx	801149-xx	-
With connector (female) and 15-pin D-sub connector (female) for the TNC (position inputs)		533627-xx	-	332115-xx
With connector (female) and 25-pin D-sub connector (female) for the TNC (speed inputs)		641926-xx	-	336376-xx
With connector (female) and 15-pin D-sub connector (male) for the IK 215, PWM 20, EIB 74x, etc.		524599-xx	801129-xx	324544-xx
With right-angle connector (female) and 15-pin D-sub connector (male) for the IK 215, PWM 20, EIB 74x, etc.		722025-xx	801140-xx	-
With connector (female) and stripped cable end		634265-xx	-	309778-xx 309779-xx ¹⁾
With right-angle connector (female) and stripped cable end		606317-xx	-	-
Cable only		-	-	816322-xx

Italics: Cable with layout for "speed encoder" input (MotEnc EnDat)

¹⁾ Without incremental signals

A_P : Cross section of power supply lines

Connecting cables Fanuc Siemens

		Cables	Fanuc
PUR connecting cables for M23 connecting element			
With 17-pin M23 connector (female) and Fanuc connector $(2 \times 2 \times 0.14 \text{ mm}^2) + (4 \times 1 \text{ mm}^2)$; $A_P = 1 \text{ mm}^2$		Ø 8 mm	534855-xx
With 17-pin M23 connector (female) and 20-pin Mitsubishi connector $(2 \times 2 \times 0.14 \text{ mm}^2) + (4 \times 0.5 \text{ mm}^2)$; $A_P = 0.5 \text{ mm}^2$		Ø 6 mm	-
With 17-pin M23 connector (female) and 10-pin Mitsubishi connector $(2 \times 2 \times 0.14 \text{ mm}^2) + (4 \times 1 \text{ mm}^2)$; $A_P = 1 \text{ mm}^2$		Ø 8 mm	-
Cable only $(2 \times 2 \times 0.14 \text{ mm}^2) + (4 \times 1 \text{ mm}^2)$; $A_P = 1 \text{ mm}^2$		Ø 8 mm	816327-xx

		Cables	Fanuc
PUR connecting cables for M12 connecting element $(1 \times 4 \times 0.14 \text{ mm}^2) + (4 \times 0.34 \text{ mm}^2)$; $A_P = 0.34 \text{ mm}^2$			
With 8-pin M12 connector (female) and Fanuc connector		Ø 6 mm	646807-xx
With 8-pin M12 connector (female) and 20-pin Mitsubishi connector		Ø 6 mm	-
With 8-pin M12 connector (female) and 10-pin Mitsubishi connector		Ø 6 mm	-

		Cables	Siemens
PUR connecting cables for M12 connecting element $2(2 \times 0.17 \text{ mm}^2) + (2 \times 0.24 \text{ mm}^2)$; $A_P = 0.24 \text{ mm}^2$			
With 8-pin M12 connector (female) and 8-pin M12 coupling (male)		Ø 6.8 mm	822504-xx
With 8-pin M12 connector (female) and RJ45 Siemens connector (IP67); cable length: 1 m		Ø 6.8 mm	1094652-01
With 8-pin M12 connector (female) and RJ45 Siemens connector (IP20)		Ø 6.8 mm	1093042-xx

A_P : Cross section of power supply lines

Signal converters

Signal converters from HEIDENHAIN adapt the encoder signals to the interface of the downstream electronics. They are used when the downstream electronics cannot directly process the output signals from HEIDENHAIN encoders or when additional interpolation of the signals is necessary.

Input signals of the signal converters

HEIDENHAIN signal converters can be connected to encoders that output 1 V_{PP} sinusoidal signals (voltage signals) or 11 μA_{PP} sinusoidal signals (current signals). Encoders with the EnDat or SSI serial interfaces can be connected to various signal converters as well.

Output signals of the signal converters

The signal converters are available with the following interfaces to the downstream electronics:

- TTL square-wave pulse trains
- EnDat 2.2
- DRIVE-CLiQ
- Fanuc Serial Interface
- Mitsubishi high speed interface
- Yaskawa Serial Interface
- PROFIBUS

Interpolation of the sinusoidal input signals

The signal converters perform signal conversion and interpolate the sinusoidal encoder signals. This permits finer measuring steps, resulting in higher control quality and superior positioning behavior.

Generation of a position value

Various signal converters feature an integrated counting function. Starting from the last set reference point, an absolute position value is generated and output to the downstream electronics when the reference mark is traversed.



Plug design



Cable design



Top-hat rail design



Outputs		Inputs		Design – IP rating	Interpolation ¹⁾ or subdivision	Model
Interface	Qty.	Interface	Qty.			
□TTL	1	~ 1 V _{PP}	1	Box design – IP65	5/10-fold	IBV 101
					20/25/50/100-fold	IBV 102
					Without interpolation	IBV 600
				Plug design – IP40	5/10-fold	IBV 3171
					20/25/50/100-fold	IBV 3271
					~ 11 μA _{PP}	1
□TTL/ ~ 1 V _{PP} (adjustable)	2	~ 1 V _{PP}	1	Box design – IP65	2-fold	IBV 6072
					5/10-fold	IBV 6172
					5/10-fold and 20/25/50/100-fold	IBV 6272
EnDat 2.2	1	~ 1 V _{PP}	1	Box design – IP65	≤ 16384-fold subdivision	EIB 192
				Plug design – IP40	≤ 16384-fold subdivision	EIB 392
				2	Box design – IP65	≤ 16384-fold subdivision
DRIVE-CLiQ	1	EnDat 2.2	1	Box design – IP65	–	EIB 2391 S
				Cable design – IP65	–	EIB 3392 S
Fanuc Serial Interface	1	~ 1 V _{PP}	1	Box design – IP65	≤ 16384-fold subdivision	EIB 192 F
				Plug design – IP40	≤ 16384-fold subdivision	EIB 392 F
	2		Box design – IP65	≤ 16384-fold subdivision	EIB 1592 F	
Mitsubishi high speed interface	1	~ 1 V _{PP}	1	Box design – IP65	≤ 16384-fold subdivision	EIB 192 M
				Plug design – IP40	≤ 16384-fold subdivision	EIB 392 M
	2		Box design – IP65	≤ 16384-fold subdivision	EIB 1592 M	
Yaskawa Serial Interface	1	EnDat 2.2	1	Plug design – IP40	–	EIB 3391 Y
PROFIBUS DP	1	EnDat 2.2	1	Top-hat rail design	–	PROFIBUS Gateway
PROFINET IO	1	EnDat 2.2	1	Top-hat rail design	–	PROFINET Gateway

¹⁾ Switchable

Testing and inspection devices, and diagnostics

HEIDENHAIN encoders provide all of the information necessary for initial setup, monitoring, and diagnostics. The type of information available depends on whether the encoder is incremental or absolute and on which interface is being used.

Incremental encoders primarily have 1 V_{PP} TTL, or HTL interfaces. TTL and HTL encoders monitor their signal amplitudes internally and generate a purely digital fault detection signal. With 1 V_{PP} signals, an analysis of the output signals is possible only with external testing devices or through the use of computation resources in the downstream electronics (**analog diagnostics interface**).

Absolute encoders employ serial data transmission. Depending on the interface, additional 1 V_{PP} incremental signals can be output. The signals are extensively monitored within the encoder. The monitoring results (specifically, valuation numbers) can be transmitted to the downstream electronics along with the position values via the serial interface (**digital diagnostics interface**).

- The following information is available:
- Error message: position value is not reliable
 - Warning: an internal functional limit of the encoder has been reached
 - Valuation numbers:
 - Detailed information about the encoder's functional reserve
 - Identical scaling for all HEIDENHAIN encoders
 - Cyclic reading is possible

This enables the downstream electronics to evaluate the current status of the encoder with little effort, even in closed loop mode

For the analysis of these encoders, HEIDENHAIN offers the appropriate PWM inspection devices and PWT testing devices. Depending on how these devices are integrated, a distinction is made between two types of diagnostics:

- Encoder diagnostics: the encoder is connected directly to the testing or inspection device, thereby enabling a detailed analysis of encoder functions.
- Monitoring mode: the PWM inspection device is linked into the closed control loop (via suitable testing adapters if needed). This enables real-time diagnosis of the machine or equipment during operation. The available functions depend on the interface.

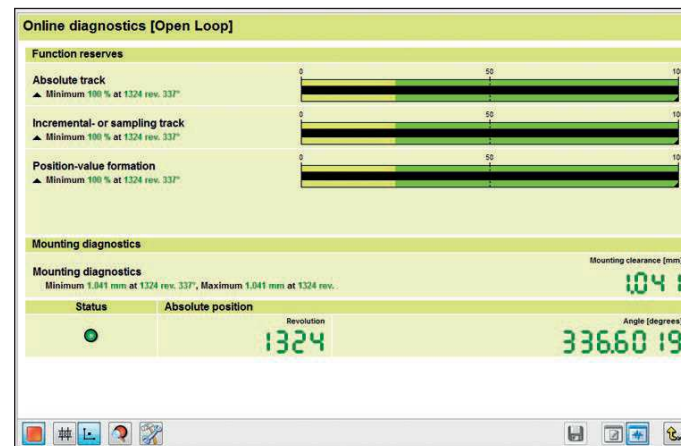

Diagnostics with the PWM 21 and ATS software



Commissioning with the PWM 21 and ATS software

Overview		PWM 21		PWT 101
Interface	Output signals	Encoder diagnostics	Monitoring mode	Encoder diagnostics
EnDat 2.1	Position value Incremental signals	Yes Yes	No Yes	Yes Yes
EnDat 2.2	Position value Valuation numbers	Yes Yes	Yes Yes ¹⁾	Yes Yes
DRIVE-CLiQ	Position value Valuation numbers	Yes Yes	No No	No ⁷⁾ No ⁷⁾
Fanuc	Position value Valuation numbers	Yes Yes	Yes Yes	Yes ⁸⁾ Yes ⁸⁾
Mitsubishi	Position value Valuation numbers	Yes Yes ⁵⁾	Yes Yes ^{1) 5)}	Yes ⁸⁾ Yes ⁸⁾
Panasonic	Position value Valuation numbers	Yes Yes	Yes Yes ¹⁾	Yes ⁸⁾ Yes ⁸⁾
Yaskawa	Position value Valuation numbers	Yes Yes ⁶⁾	No ⁷⁾ No ⁷⁾	Yes ⁸⁾ Yes ⁸⁾
SSI	Position value Incremental signals	Yes Yes	No Yes	No No
1 V _{PP}	Incremental signals	Yes	Yes	Yes
11 μA _{PP}	Incremental signals	Yes	Yes	Yes
TTL	Incremental signals Scanning signals	Yes Yes ⁴⁾	Yes No	Yes Yes ⁴⁾
HTL	Incremental signals	Yes ²⁾	No	No ⁷⁾
Commutation	Block commutation Sinusoidal commutation	Yes ²⁾ Yes	No Yes	Yes ³⁾ Yes

¹⁾ Information must be requested and transferred by the control

²⁾ Via the appropriate signal adapter

³⁾ Only for encoders with block commutation (see encoder documentation)

⁴⁾ If supported by the encoder (PWT function)

⁵⁾ Not available for encoders with the ordering designation Mitsu01

⁶⁾ Not available for the EIB 3391Y

⁷⁾ Function not available yet

⁸⁾ Two-pair transmission is required (for more information, see the documentation for the PWT 100/PWT 101)

PWT 101

The PWT 101 is a testing device for the functional testing and adjustment of incremental and absolute HEIDENHAIN encoders. Thanks to its compact dimensions and rugged design, the PWT 101 is ideal for portable use.

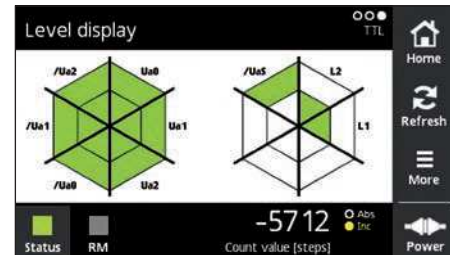

Level display

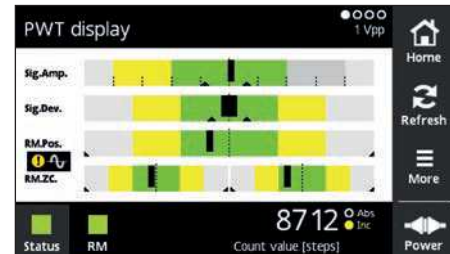

PWT display

Testing device	PWT 101
Area of application	<ul style="list-style-type: none"> The functional testing of absolute and incremental HEIDENHAIN encoders
Encoder input only for HEIDENHAIN encoders	<ul style="list-style-type: none"> EnDat Fanuc Serial Interface Mitsubishi high speed interface Panasonic Serial Interface Yaskawa Serial Interface 1 V_{PP} with Z1 track 1 V_{PP} 11 μA_{PP} TTL
Display	4.3-inch touchscreen
Supply voltage	DC 24 V Power consumption: max. 15 W
Operating temperature	0 °C to 40 °C
Protection EN 60529	IP20
Dimensions	≈ 145 mm × 85 mm × 35 mm
Languages	German, English, French, Italian, Spanish, Japanese, Korean, Chinese (simplified), Chinese (traditional)

PWM 21

The PWM 21 phase-angle measuring unit, in conjunction with the ATS adjusting and testing software, serves as an adjusting and testing package for the diagnosis and adjustment of HEIDENHAIN encoders.



For more information, please refer to the *PWM 21/ATS Software* Product Information document.

	PWM 21
Encoder input	<ul style="list-style-type: none"> EnDat 2.1 or EnDat 2.2 (absolute value with or without incremental signals) DRIVE-CLiQ Fanuc Serial Interface Mitsubishi high speed interface Yaskawa Serial Interface Panasonic serial interface SSI 1 V_{PP}/TTL/11 μA_{PP} HTL (via signal adapter)
Interface	USB 2.0
Supply voltage	AC 100 V to 240 V or DC 24 V
Dimensions	258 mm × 154 mm × 55 mm

	ATS
Languages	German or English (selectable)
Functions	<ul style="list-style-type: none"> Position display Connection dialog Diagnostics Mounting wizard for the EBI/ECI/EQI, LIP 200, LIC 4000, and others Additional functions (if supported by the encoder) Memory contents
System requirements and recommendations	PC (dual-core processor > 2 GHz) RAM > 2 GB Operating systems: Windows 7, 8, and 10 (32-bit / 64-bit) 500 MB of free hard drive space

DRIVE-CLiQ is a registered trademark of Siemens AG.

HEIDENHAIN

DR. JOHANNES HEIDENHAIN GmbH

Dr.-Johannes-Heidenhain-Straße 5
83301 Traunreut, Germany

☎ +49 8669 31-0

FAXI +49 8669 32-5061

E-mail: info@heidenhain.de

www.heidenhain.de

Vollständige und weitere Adressen siehe www.heidenhain.de
For complete and further addresses see www.heidenhain.com

DE	HEIDENHAIN Vertrieb Deutschland 83301 Traunreut, Deutschland ☎ 08669 31-3132 FAXI 08669 32-3132 E-Mail: hd@heidenhain.de	DK	Denmark → SE	NZ	Llama ENGINEERING Ltd Lower Hutt 5010, New Zealand E-mail: heidenhain@llamaengineering.co.nz
	HEIDENHAIN Technisches Büro Nord 12681 Berlin, Deutschland ☎ 030 54705-240	ES	FARRESA ELECTRONICA S.A. 08028 Barcelona, Spain www.farresa.es	PH	MACHINEBANKS' CORPORATION Quezon City, Philippines 1113 E-mail: info@machinebanks.com
	HEIDENHAIN Technisches Büro Mitte 07751 Jena, Deutschland ☎ 03641 4728-250	FI	HEIDENHAIN Scandinavia AB 01740 Vantaa, Finland www.heidenhain.fi	PL	APS 02-384 Warszawa, Poland www.heidenhain.pl
	HEIDENHAIN Technisches Büro West 44379 Dortmund, Deutschland ☎ 0231 618083-0	FR	HEIDENHAIN FRANCE sarl 92310 Sèvres, France www.heidenhain.fr	PT	FARRESA ELECTRÓNICA, LDA. 4470 - 177 Maia, Portugal www.farresa.pt
	HEIDENHAIN Technisches Büro Südwest 70771 Leinfelden-Echterdingen, Deutschland ☎ 0711 993395-0	GB	HEIDENHAIN (G.B.) Limited Burgess Hill RH15 9RD, United Kingdom www.heidenhain.co.uk	RO	HEIDENHAIN Reprezentantă Romania Braşov, 500407, Romania www.heidenhain.ro
	HEIDENHAIN Technisches Büro Südost 83301 Traunreut, Deutschland ☎ 08669 31-1337	GR	MB Milionis Vassilis 17341 Athens, Greece www.heidenhain.gr	RS	Serbia → BG
		HR	Croatia → SL	RU	GERTNER Service 119002 Moscow, Russian Federation www.heidenhain.ru
		HU	HEIDENHAIN Kereskedelmi Képviselet 1239 Budapest, Hungary www.heidenhain.hu	SE	HEIDENHAIN Scandinavia AB 12739 Skärholmen, Sweden www.heidenhain.se
AR	NAKASE SRL. B1653AOX Villa Ballester, Argentina www.heidenhain.com.ar	ID	PT Servitama Era Toolsindo Jakarta 13930, Indonesia E-mail: ptset@group.gts.co.id	SG	HEIDENHAIN PACIFIC PTE LTD Singapore 408593 www.heidenhain.com.sg
AT	HEIDENHAIN Techn. Büro Österreich 83301 Traunreut, Germany www.heidenhain.de	IL	NEUMO VARGUS MARKETING LTD. Holon, 5885948, Israel E-mail: neumo@neumo-vargus.co.il	SK	KOPRETINA TN s.r.o. 91101 Trencin, Slovakia www.kopretina.sk
AU	FCR MOTION TECHNOLOGY PTY LTD Ravenhall Victoria 3023, Australia E-mail: sales@fcrmotion.com	IN	HEIDENHAIN Optics & Electronics India Private Limited Chetpet, Chennai 600 031, India www.heidenhain.in	SL	NAVO d.o.o. 2000 Maribor, Slovenia www.heidenhain.si
BE	HEIDENHAIN NV 1760 Roosdaal, Belgium www.heidenhain.be	IT	HEIDENHAIN ITALIANA S.r.l. 20128 Milano, Italy www.heidenhain.it	TH	HEIDENHAIN (THAILAND) LTD Bangkok 10250, Thailand www.heidenhain.co.th
BG	ESD Bulgaria Ltd. Sofia 1172, Bulgaria www.esd.bg	JP	HEIDENHAIN K.K. Tokyo 102-0083, Japan www.heidenhain.co.jp	TR	T&M Mühendislik San. ve Tic. LTD. ŞTİ. 34775 Y. Dudullu – Umraniye-Istanbul, Turkey www.heidenhain.com.tr
BR	HEIDENHAIN Brasil Ltda. 04763-070 – São Paulo – SP, Brazil www.heidenhain.com.br	KR	HEIDENHAIN Korea Ltd. Anyang-si, Gyeonggi-do, 14087 South Korea www.heidenhain.co.kr	TW	HEIDENHAIN CO., LTD. Taichung 40768, Taiwan www.heidenhain.com.tw
BY	GERTNER Service 220026 Minsk, Belarus www.heidenhain.by	MX	HEIDENHAIN CORPORATION MEXICO 20290 Aguascalientes, AGS., Mexico E-mail: info@heidenhain.com	UA	GERTNER Service 02094 Kiev, Ukraine www.heidenhain.ua
CA	HEIDENHAIN CORPORATION Mississauga, Ontario L5T2N2, Canada www.heidenhain.com	MY	ISOSERVE SDN. BHD. 43200 Balakong, Selangor E-mail: sales@isoserve.com.my	US	HEIDENHAIN CORPORATION Schaumburg, IL 60173-5337, USA www.heidenhain.us
CH	HEIDENHAIN (SCHWEIZ) AG 8603 Schwerzenbach, Switzerland www.heidenhain.ch	NL	HEIDENHAIN NEDERLAND B.V. 6716 BM Ede, Netherlands www.heidenhain.nl	VN	AMS Co. Ltd HCM City, Vietnam E-mail: davidgoh@amsvn.com
CN	DR. JOHANNES HEIDENHAIN (CHINA) Co., Ltd. Beijing 101312, China www.heidenhain.com.cn	NO	HEIDENHAIN Scandinavia AB 7300 Orkanger, Norway www.heidenhain.no	ZA	MAFEMA SALES SERVICES C.C. Kyalami 1684, South Africa www.heidenhain.co.za
CZ	HEIDENHAIN s.r.o. 102 00 Praha 10, Czech Republic www.heidenhain.cz				

SALES & SERVICE:

A Tech Authority, Inc.
13745 Stockton Ave.
Chino CA 91710
909-614-4522
sales@atechauthority.com