

# SJ

## SJ700A SERIES

Cost-effective scale for Digital readout.

- Magnetic based encoder
- Excellent resistance to workshop conditions
- Same coefficient of expansion as that of machine tools
- Measuring length: 150 mm to 1600 mm / 5.9" to 62.9"
- Accuracy:  $\pm 10 \mu\text{m}$ ,  $\pm 15 \mu\text{m}$
- Resolution:  $5 \mu\text{m}$

Scale	Counter
SJ700A	LH70/71, LH72 LY71, LY72, LG20

**SALES & SERVICE:**  
**A Tech Authority, Inc.**  
 13745 Stockton Ave.  
 Chino CA 91710  
 909-614-4522  
 sales@atechauthority.com



### Dimensions

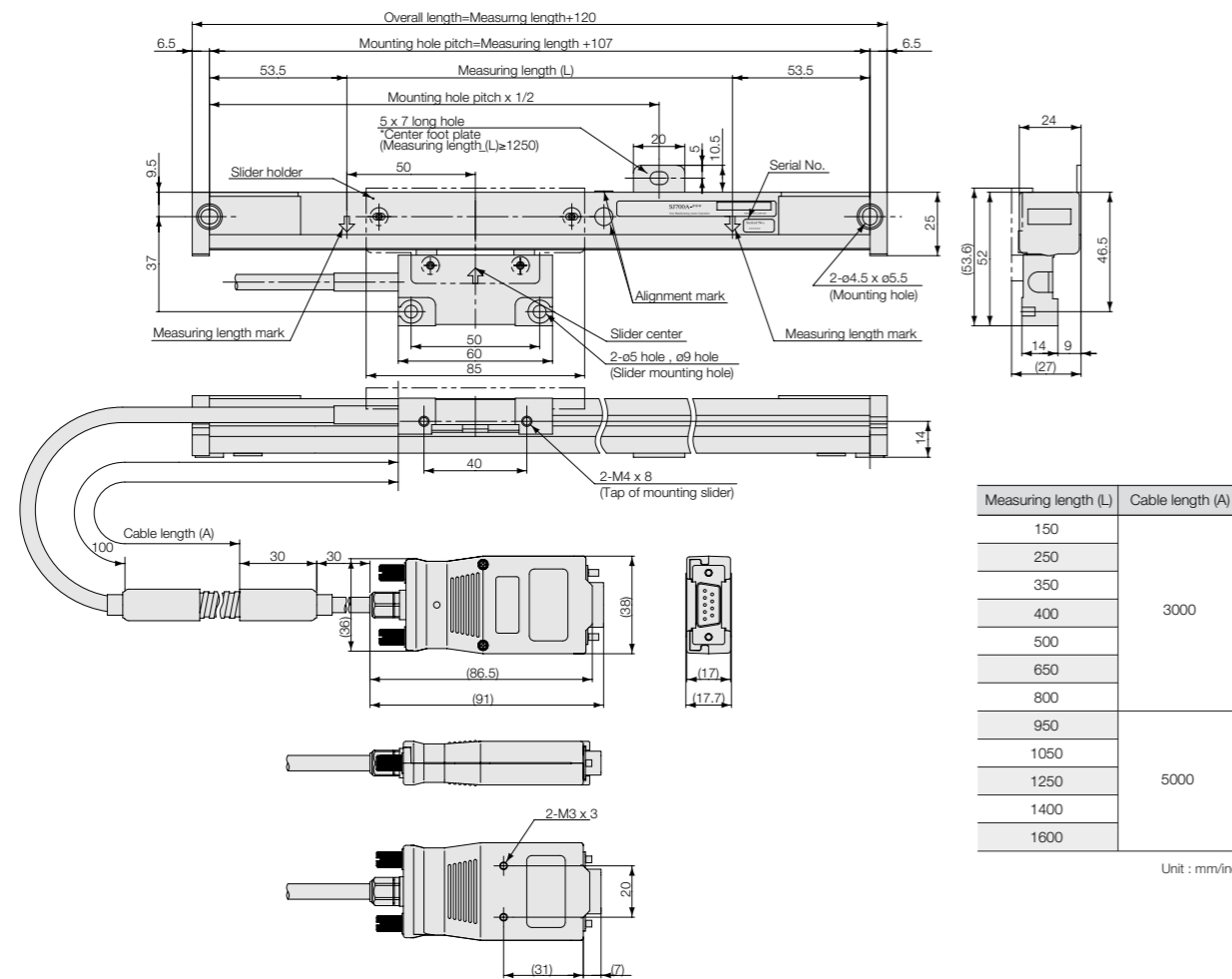

### Specifications

Model	SJ700A
Effective length L:mm(inch)	150 (5.9"), 250 (9.8"), 350 (13.7"), 400 (15.7"), 500 (19.6"), 650 (25.5"), 800 (31.5"), 950 (37.4"), 1050 (41.3"), 1250 (49.2"), 1400 (55.1"), 1600 (62.9")
Overall length	Measuring length + 120 (4.73")
Maximum travel	Measuring length + 20 (0.78") (10 (0.39") each at right and left)
Accuracy (at 20°C/68°F)	$\pm 10 \mu\text{m}$ (Measuring length 1250 (49.21") or less) $\pm 15 \mu\text{m}$ (Measuring length 1400 (55.12") or more)
Thermal expansion coefficient	$(12 \pm 1) \times 10^{-6}/^\circ\text{C}$
Cable length	3 m (9.8 ft) (SJ700A-015 to 080), 5 m (16.4 ft) (SJ700A-095 to 160)
Operating temperature	0 to +40°C (+32 to +104°F)
Storage temperature	-20 to +60°C (4 to +140°F)
Operating humidity	Condensation allowed
Storage humidity	90%

# SL

## SL110/SL130

Non-contact detection and a long measuring range

**SALES & SERVICE:**  
**A Tech Authority, Inc.**  
 13745 Stockton Ave.  
 Chino CA 91710  
 909-614-4522  
 sales@atechauthority.com

- Magnetic principle
- Excellent resistance to workshop conditions (PL20C equivalent to IP65). Resistant to oil, dirt, vibration, and shock.
- Resolution:  $10 \mu\text{m}$
- Max. response speed: 300 m/ min (varies with the read head and settings).
- Available in lengths up to 30 m (SL130)
- High cost efficiency. Easy installation on all types of machines from wood working to metal cutting.

Scale	Head/Cable	Counter
SL110/130	PL20C	LH70/71, LH72 LY71, LY72, LG20

### Dimensions

SL110

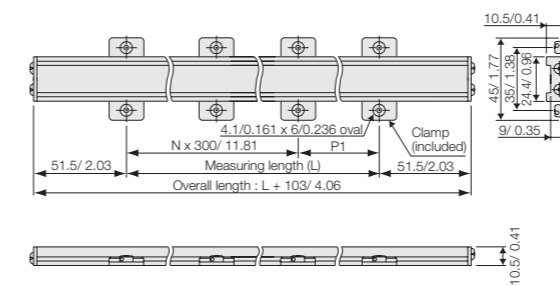

Model name	Effective length	N	P1	Number of Clamps
SL110-20	200	0	200	4
SL110-30	300	1	0	4
SL110-40	400	1	100	6
SL110-50	500	1	200	6
SL110-60	600	2	0	6
SL110-70	700	2	100	8
SL110-80	800	2	200	8
SL110-100	1000	3	100	10
SL110-120	1200	4	0	10
SL110-150	1500	5	0	12
SL110-160	1600	5	100	14
SL110-170	1700	5	200	14
SL110-180	1800	6	0	14
SL110-200	2000	6	200	16

SL130

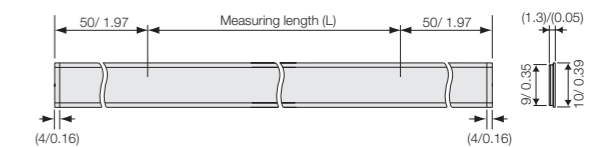

Model name	Effective length	Movable length	Overall length
SL130-20	200	230	300
SL130-30	300	330	400
SL130-40	400	430	500
SL130-50	500	530	600
SL130-60	600	630	700
SL130-70	700	730	800
SL130-80	800	830	900
SL130-100	1000	1030	1100
SL130-120	1200	1230	1300
SL130-150	1500	1530	1600
SL130-160	1600	1630	1700
SL130-170	1700	1730	1800
SL130-180	1800	1830	1900
SL130-200	2000	2030	2100
SL130-250	2500	2530	2600
SL130-300	3000	3030	3100
SL130-400	4000	4030	4100
SL130-500	5000	5030	5100
SL130-600	6000	6030	6100
SL130-700	7000	7030	7100
SL130-800	8000	8030	8100

Unit : mm/inch

### SL110/130 Specifications

Model	SL110	SL130	
	-20 to -200	-20 to -700	-800 to -3000
Effective length L mm (inch)	200/300/400/500/600/700/800/1000/1200/ 1500/1600/1700/1800/2000 (7.8/11.8/15.7/19.6/23.6/27.5/31.4/39.3/47.2/ 59.0/62.9/66.9/70.8/78.7)	200/300/400/500/600/700/800/1000/1200/ 1500/1600/1700/1800/2000/2500/3000/ 4000/5000/6000/7000 (7.8/11.8/15.7/19.6/23.6/27.5/31.4/39.3/ 47.2/59.0/62.9/66.9/70.8/78.7/98.4/118.1/ 157.4/196.8/236.2/275.5)	8000/9000/10000/20000/30000 (314.9/354.3/393.7/787.4/1181.1)
Overall length	L+103 mm/ 4.1"	L+100 mm/ 3.9"	
Accuracy (at 20°C/68°F)	$\pm (25 + 5L/1000) \mu\text{m}$		$\pm (25 + 5L/1000 + 10N) \mu\text{m}$ N=1 when L=8000 /9000/10000, N=2 when L=20000, N=3 when L=30000
Resolution	10 $\mu\text{m}$		
Max. response speed	300 m/ min		
Expansion coefficient	$(11.1 \pm 1) \times 10^{-6}/^\circ\text{C}$		$(10.4 \pm 1) \times 10^{-6}/^\circ\text{C}$
Operating temperature	-5°C to 45°C / 23°F to 113°F		
Storage temperature	-10°C to 50°C / 14°F to 122°F		
Compatible read head	PL20C		

\*Accuracy shows the value when used with PL20C read head.

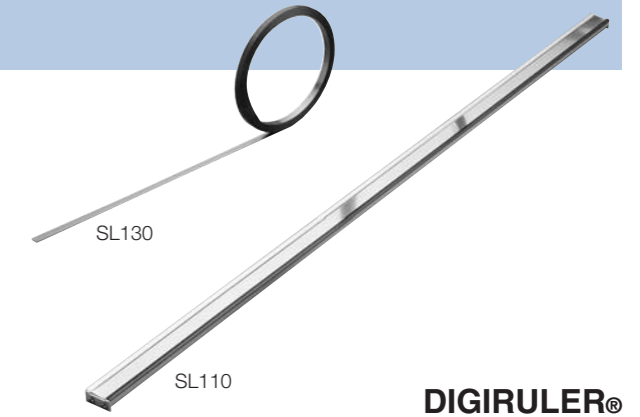

**DIGIRULER®**