

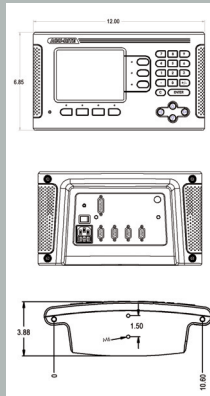

WIZARD 550 Features/Technical Data

Display	2- or 3-axes 5.7" transmissive LCD display
Common Functions	<ul style="list-style-type: none"> • Near-zero warning • Help function • 16 tool offsets / diameter • Preset and zero reset • 4 function calculator / Trig calculator • Instant inch/mm conversion • Position-Trac™
Milling Specific Functions	<ul style="list-style-type: none"> • Bolthole pattern calculations with graphics (full and partial circles) • Centerline calculation enables you to establish workpiece zero and midpoints • Edge finder input
Turning/General Specific Functions	<ul style="list-style-type: none"> • Lock axis feature • Instant radius / diameter conversion • Taper calculator
Error Compensation	Linear and non-linear compensation up to +/-9,999 ppm
Construction	Die-cast metal
Data Interface	RS-232-C/V.24 serial port
Electrical Requirements	Voltage of 100-240 Vac Power of 30 VA max Frequency of 50/60 Hz (+/-3Hz)
Operating Temperature	0 degrees to 45 degrees C (32 degrees to 113 degrees F)
Storage Temperature	-20 degrees to 70 degrees C (-22 degrees to 158 degrees F)
Weight	4.85 lbs.
Certifications	ISO-9001, UL, CSA, CE



ANILAM[®]
THE CLEAR CHOICE.

P.N. 73000-231 Rev. 12/05



ANILAM IS AN
ISO 9001
CERTIFIED
MANUFACTURER
CE



Precision Glass Scales.

With more than one million scales in use today, ANILAM precision glass scales withstand the elements of contamination found in even the harshest machine shop environments. As a result, our precision glass scales resist changes in size, shape or density due to temperature and humidity variations. This stability provides exceptional accuracy down to $\pm 1.5\mu\text{m}$ (.00006"), resulting in tighter workpiece tolerances. ANILAM precision glass scales are available in travel lengths from 1"-773" and in resolutions from $0.5\mu\text{m}$ (.00002") to $10\mu\text{m}$ (.0005").

ANILAM USA

One Precision Way, Jamestown, NY 14701
Tel: 800.344.2311 Fax: 716.661.1884
Web: www.anilam.com / E-mail: anilaminc@anilam.com

Acu-Rite Companies China

Room 1986, Tower B, City Center of Shanghai
No. 100 Zunyi Lu Road, Chang Ning District
200051 Shanghai P.R.C
Tel: 011.86.21.62370398 Fax: 011.86.21.62372320
E-mail: china@anilam.com

ANILAM S.A.R.L France

2 Avenue de la Cristallerie, BP 68-92316
Serves Cedex, France
Tel: 011.33.1.46290061 Fax: 011.33.1.45072402
Web: www.acu-rite.fr / E-mail: courrier@acu-rite.fr

ANILAM GmbH Germany

Fraunhoferstrasse 1, D-83301, Traunreut, Germany
Tel: 011.49.8669.856110 Fax: 011.49.8669.850930
Web: www.anilam.de / E-mail: info@anilam.de

ANILAM s.r.l Italy

Strada Borgaretto, 38, 10043 Orbassano, Torino, Italy
Tel: 011.39.011.900.2606 Fax: 011.39.011.900.2466
Web: www.anilam.it / E-mail: info@anilam.it

ANILAM TW Taiwan

No. 246 Chau-Fu Road, Taichung City 407, Taiwan, ROC
Tel: 011.886.4.225.87222 Fax: 011.886.4.225.87260
E-mail: anilamtw@anilam.com

ACI (UK) Limited

16 Plover Close, Interchange Park, Newport Pagnell
Buckinghamshire, MK16 9PS United Kingdom
Tel: 011.44.0.1908.514.500 Fax: 011.44.0.1908.610.111
Web: www.aciuk.co.uk / E-mail: sales@aciuk.co.uk

WIZARD 550

LCD Digital Readouts

The Clear Choice.

SALES & SERVICE:

A Tech Authority, Inc.
13745 Stockton Ave.
Chino CA 91710
909-614-4522
sales@atechauthority.com

Intuitive, operator-friendly keypad with machine-specific software and easy-to-read flat-screen LCD display.

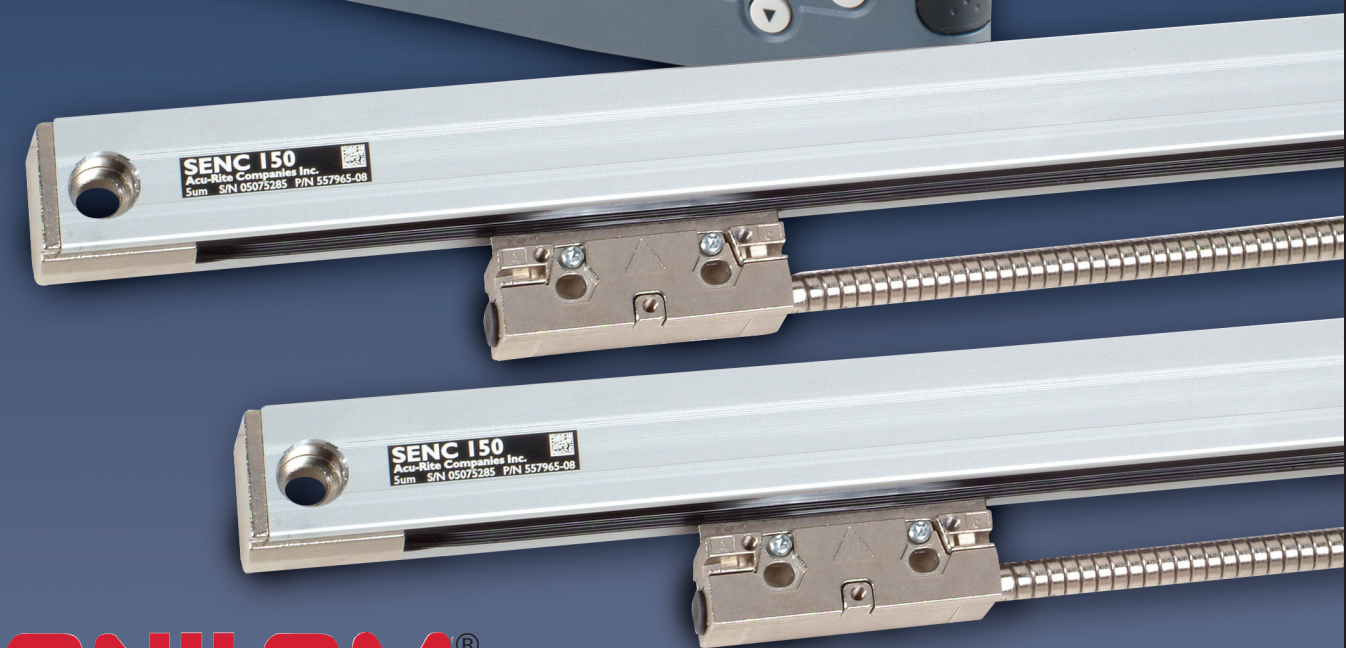

ANILAM[®]

It's crystal clear.



The ANILAM WIZARD 550 features exclusive LCD display screen technology and versatile software to accommodate milling, turning or grinding applications – all with the same bright, crystal clear readout. Plus, a content-sensitive help function assists you in troubleshooting any difficulty.

All ANILAM products are designed and manufactured in ANILAM's ISO 9001 certified facility. They are designed to UL/CSA/CE specifications and are backed by a 3-year Hassle-Free Warranty.

ANILAM maintains a strong worldwide authorized distribution network of fully trained and qualified personnel to provide quality sales and service support. ANILAM's authorized distribution network is readily available to provide prompt delivery, thorough product training and skilled technical service.

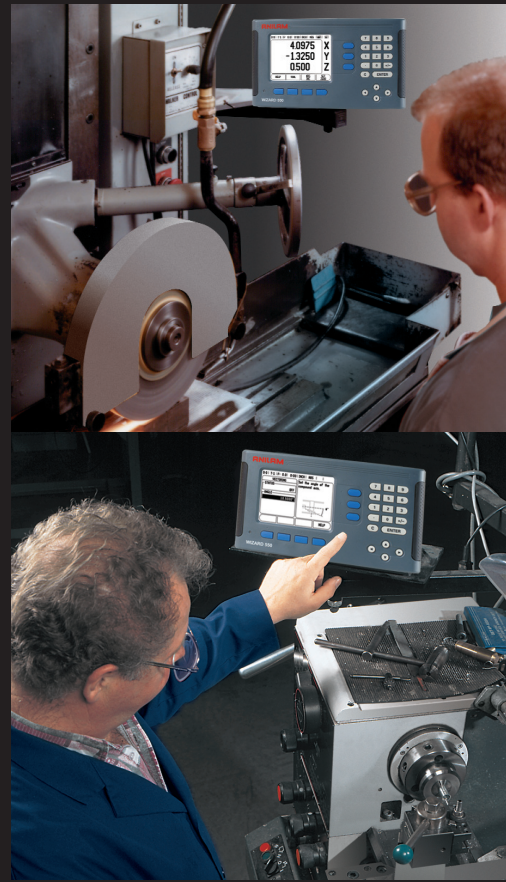

WIZARD 550 for Turning Applications.



It's intuitive.

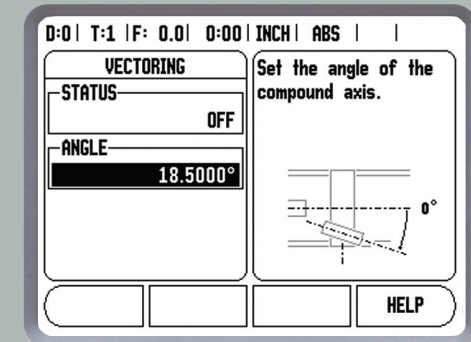

The ultimate in efficiency and productivity for turning applications utilizing state-of-the-art features.

- > 16 Tool Offsets for easy compensation of different tool sizes
- > Lock Axis feature, used in conjunction with tool offsetting, lets you establish tool offsets with the tool under load, resulting in reduced tool deflection
- > Instant radius/diameter conversion reduces math errors and allows you to machine to print dimensions
- > Position-Trac™ – a unique feature that lets you easily, quickly and accurately reestablish workpiece zero after power loss
- > 2- or 3-axes LCD display
- > Preset and zero reset
- > Near-zero warning
- > Instant inch/mm conversion
- > Linear and non-linear error compensation

WIZARD 550 for Milling Applications.

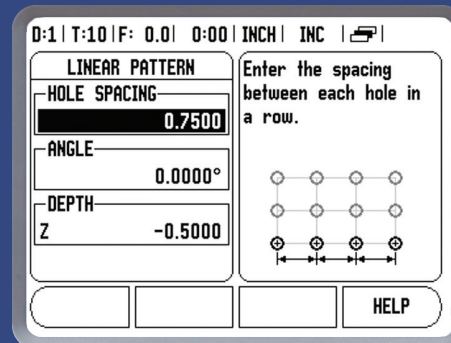

Updated, state-of-the-art features for milling at an affordable price.

- > Bolthole pattern calculations with graphics (full and partial circles)
- > Centerline calculation enables you to establish workpiece zero and midpoints
- > 16 tool offsets/diameter
- > 2- or 3-axes LCD display
- > Preset and zero reset
- > Near-zero warning
- > Instant inch/mm conversion
- > Linear and non-linear error compensation
- > Electronic edge finder input
- > Position-Trac™ – a unique feature that lets you easily, quickly and accurately reestablish workpiece zero after power loss

It's user-friendly.

WIZARD 550 for Grinding and General Purpose Applications.

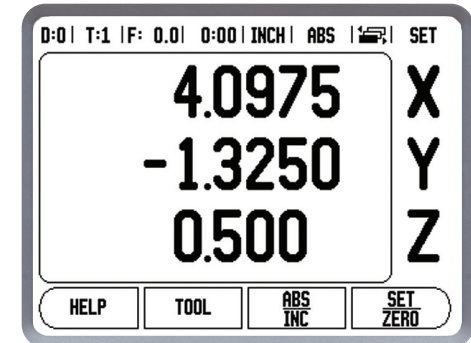

Increase the accuracy of grinding and general purpose applications with efficient and productive features.

- > 2- or 3-axes LCD display
- > Preset and zero reset
- > Near-zero warning
- > Instant radius/diameter conversion to reduce math errors and allow you to machine to print dimensions
- > Position-Trac™ – a unique feature that lets you easily, quickly and accurately reestablish workpiece zero after power loss
- > Absolute/incremental display
- > Instant inch/mm conversion
- > Linear and non-linear error compensation

And it's versatile.

Go to www.anilam.com for more information. Or call **800-344-2311**.