

**SALES & SERVICE:**



A Tech Authority, Inc.  
13745 Stockton Ave.  
Chino CA 91710  
909-614-4522  
sales@atechauthority.com



# XR20 rotary axis calibrator

## Why you need an XR20 rotary axis calibrator

Rotary axis positioning is critical to machine accuracy. The XR20 rotary axis calibrator provides rapid calibration of rotary axes, to  $\pm 1$  arc second accuracy, for stages, jigs and machine tools.

Build	
<input checked="" type="checkbox"/> Verify	<input checked="" type="checkbox"/>
<input checked="" type="checkbox"/> Compensate	<input checked="" type="checkbox"/>
Diagnose	

[www.renishaw.com/xr20](http://www.renishaw.com/xr20)

 #renishaw

## Process foundation

Component quality is dependent on machine performance. Without understanding the errors in a machine it is impossible to have confidence that your components will meet specification.

Accurate measurement and setup of machines is the foundation of process control, providing the best performance and stable environment for the machining process. Quantifying process capability reduces costs and improves efficiency.



## Highly accurate and repeatable rotary axis calibration

Historically, machine tool rotary axes were confined to large machines, or small indexing tables. As the introduction of smaller 5-axis machine tools and mill-turn designs increases, so do the challenges associated with their measurement.

As with linear axes, rotary axes are subject to errors relative to the intended positioning. This can be due to machine installation errors, collisions or general wear in use. Errors in either the angular positioning accuracy or alignment of the axes can produce significant defects in finished parts.

Early error detection with the XR20 rotary axis calibrator permits optimum machine performance to be achieved. The calibration data can be used to check for errors, establish performance trends and efficiently schedule maintenance and repairs. The XR20 works in conjunction with Renishaw's XL-80, XM-60 and XM-600 laser systems.

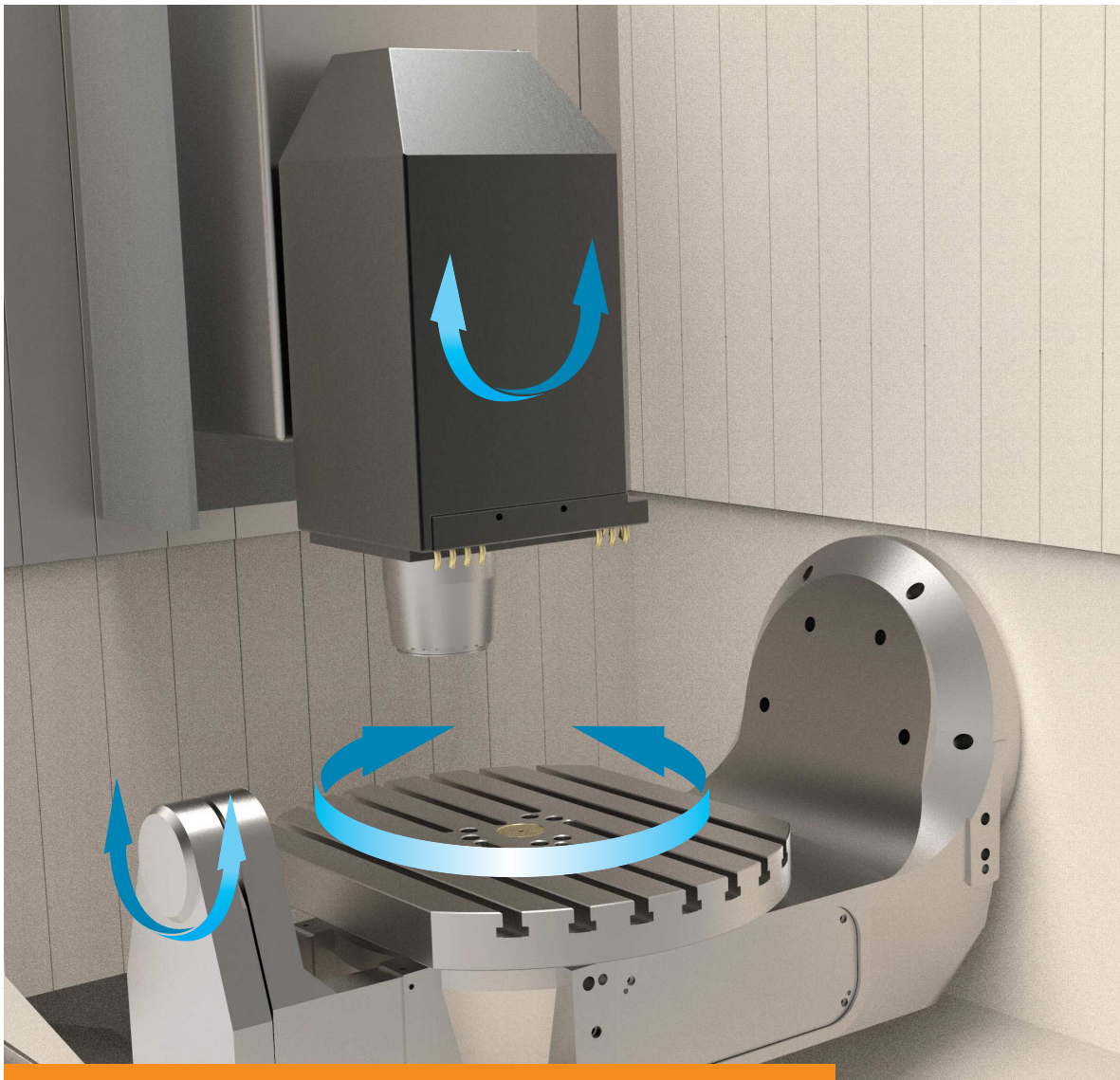

XR20 calibrates rotary axes, improving the accuracy of 5-axis machining

# System overview

The XR20 consists of an integrated angular retroreflector mounted on a precision servo-controlled axis. The angular position of this axis, and the optics relative to the main body housing, is controlled by a very high accuracy encoder system with the scale directly machined onto the main bearing.

## Key features and benefits

### ✓ Flexible and lightweight

designed for single-handed easy fitment to a wide variety of rotary tables, lathes and other rotary axes

### ✓ High accuracy

$\pm 1$  arc second verification of rotary axes in any orientation

### ✓ Rapid testing

quick test setup and fast data capture

### ✓ Wireless operation

powered by rechargeable batteries and integrated wireless connection using Bluetooth® low energy communication

### ✓ Built-in alignment targets

minimises measurement errors during setup

### ✓ Auto calibration

pre-measurement calibration cycle compensates for angular alignment errors

### ✓ Pre-test cycles

automatic direction and feedrate detection

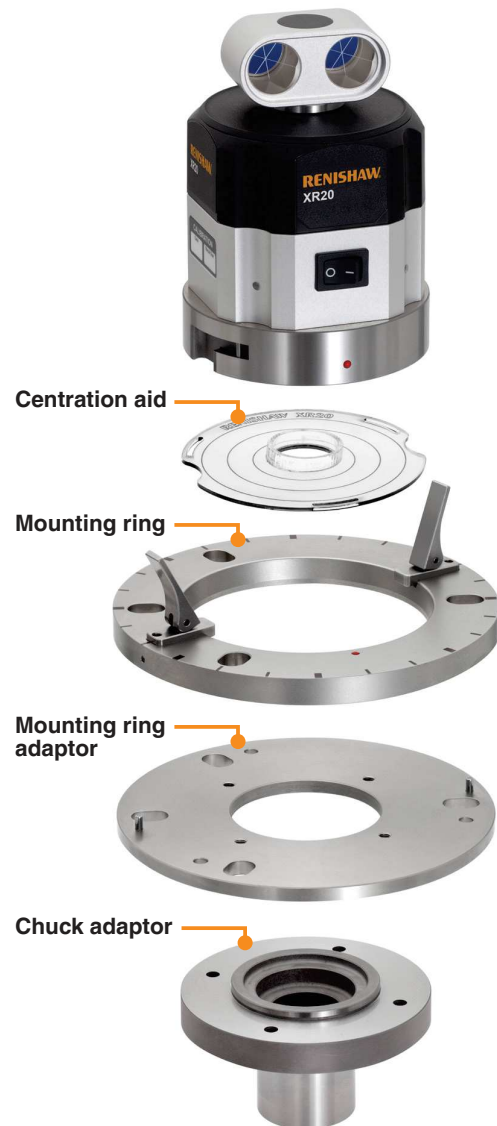

## Easy to use mounting options

Mounting the XR20 to rotary axes is simplified using a range of modular mounts to suit different applications.

### Standard mounting

Centring on the axis is typically very simple, using the markings around the circumference of the mounting ring and the centration aid.

### Flexible mounting

A mounting ring adaptor plate enables the XR20 to be fitted to rotary tables with unsuitable centre recesses. It can also be used to secure the XR20 to the chuck (lathe) adaptor and custom mounts.

The Bluetooth word mark and logos are owned by Bluetooth SIG, Inc. and any use of such marks by Renishaw plc is under license. Other trademarks and trade names are those of their respective owners.

## Off axis rotary measurement

Some rotary axis calibration systems require that the measuring device is mounted on the centre of the machine's rotational axis. This can lead to difficulties on machines where access to the centre of rotation is limited, such as trunnion and swivel head machine configurations as shown in Figure A.

The Renishaw solution allows the XR20 to be mounted easily and a test program automatically generated using CARTO software. This synchronises linear and rotary moves so that the laser beam alignment is maintained throughout a test as shown in Figure B.

### Off axis rotary software

Renishaw's off axis rotary software allows the user to:

- automatically calculate the offset distance between the centre of rotation of the XR20 and the centre of rotation of the rotary axis
- generate a test part program (which synchronises rotary axis and linear axis moves to maintain laser beam alignment)
- remove any contributory linear axis angular error from the observed rotary axis results, giving 'clean' results for the rotary axis

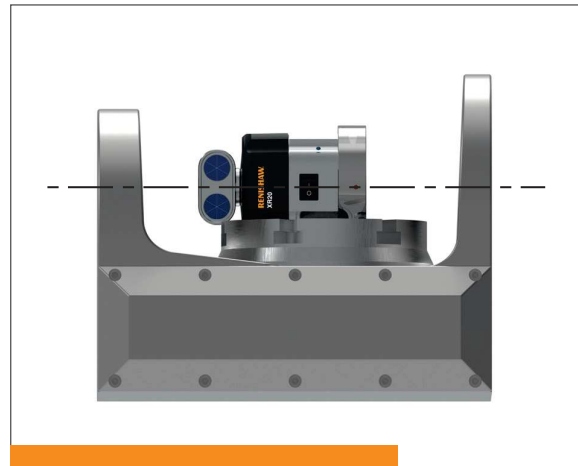

Figure A: On axis mounting

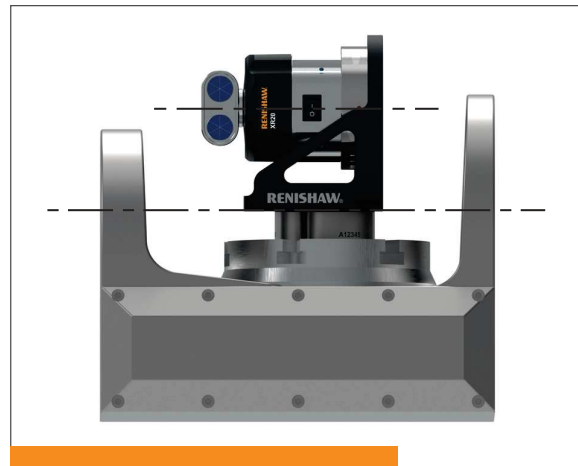

Figure B: Off axis mounting

### Off axis mounting hardware

The XR20 90° bracket provides an extremely accurate perpendicular mounting system. It can be used for both 'on' and 'off' axis rotary measurements, minimising or eliminating alignment adjustments required to achieve full  $\pm 1$  arc second rotary error measurements.

The bracket can be mounted with the removable high strength magnets or using the through holes for direct bolt attachment.





“ The XR20 features many improvements over its RX10 predecessor, including Bluetooth wireless technology which makes the data capture process more reliable. Renishaw has a strong reputation in metrology so some of our customers specifically request that we use Renishaw’s calibration products for commissioning.

Kunming Machine Tool Company Ltd (China)

”

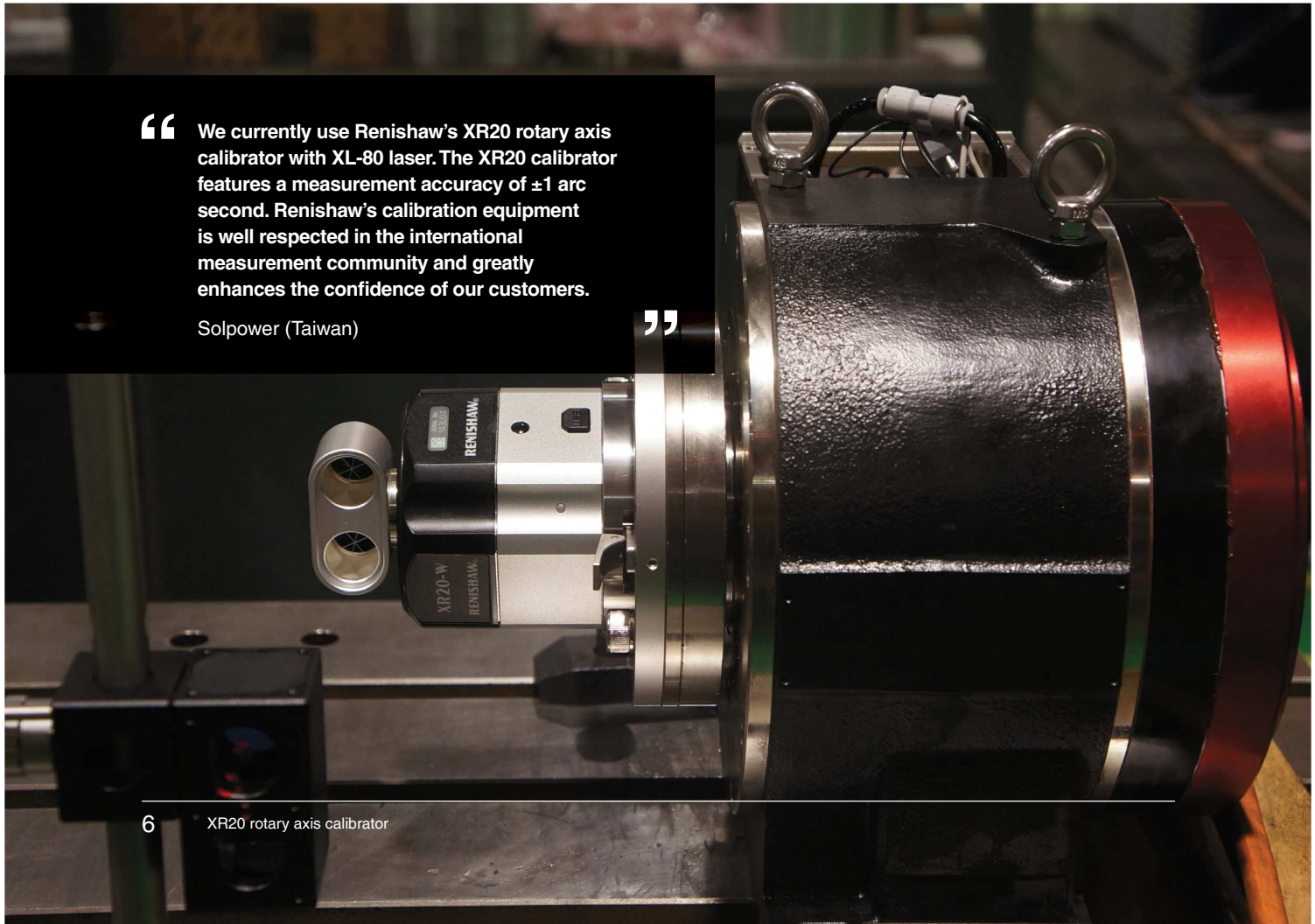

“ We currently use Renishaw’s XR20 rotary axis calibrator with XL-80 laser. The XR20 calibrator features a measurement accuracy of  $\pm 1$  arc second. Renishaw’s calibration equipment is well respected in the international measurement community and greatly enhances the confidence of our customers.

Solpower (Taiwan)

”

## CARTO software suite

The CARTO software suite is used for capturing data, analysis and compensation for rotary measurement using the XL-80 laser or XM-60 multi-axis calibrator.

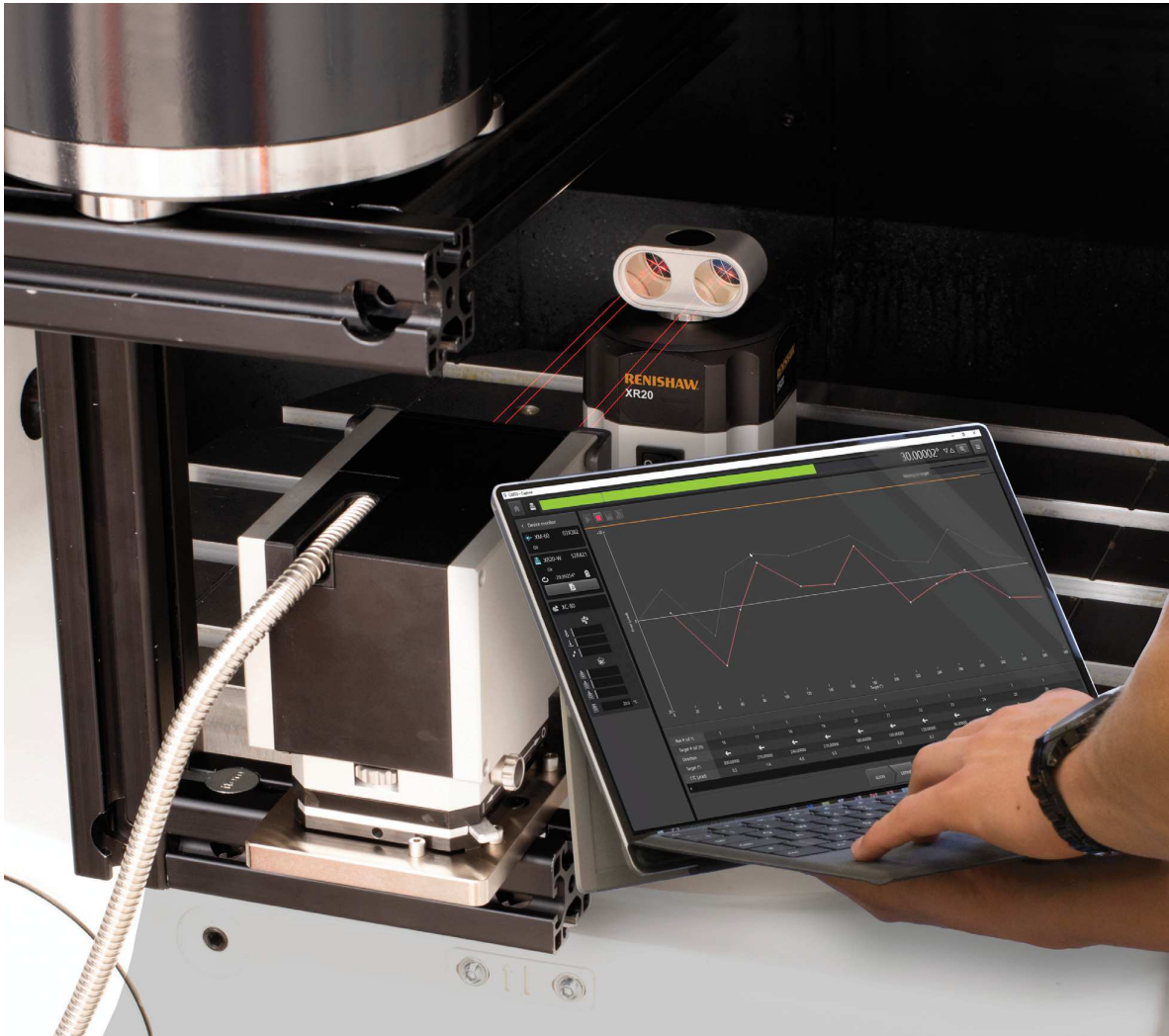

### CARTO is made up of three applications:

**Capture**  
to collect laser measurement data

**Explore**  
for powerful analysis to international standards

**Compensate**  
for quick and easy error correction

The CARTO user interface provides a simple process flow that enables users to easily capture and manage their data.

Built in functions such as 'automatic sign detection' and 'first target pre-set' give confidence that collected data is right first time. This approach allows for greater productivity whilst using Renishaw calibration products.

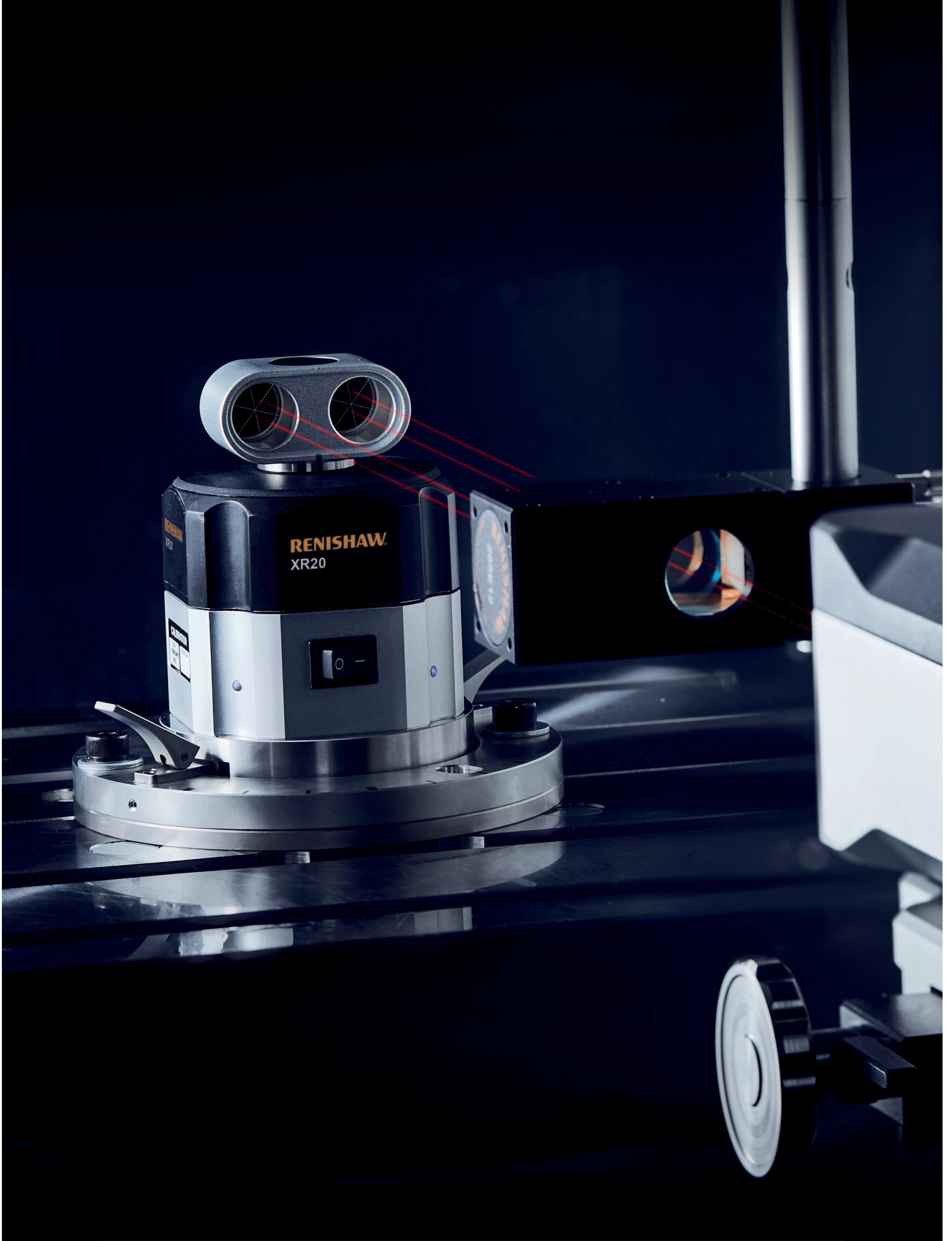



# XR20 system specification

## System specification

XR20 system	
Max feed rate (> 5° axis rotation)	10 rpm
Max feed rate (< 5° axis rotation)	Unlimited
Height	130 mm
Diameter	Ø100 mm (Ø150 mm on mounting plate)
Weight	1.2 kg (kit 6.5 kg)
Interface	Integral USB comms, no separate interface

## Performance specification

Rotary (with XL-80)	
Accuracy	±1 arcsec (at 20 °C)
Resolution	0.1 arcsecs
Range	0° to 360°
Rotary (with XM-60 or XM-600)	
Accuracy	±1.2 arcsecs (at 20 °C)
Resolution	0.1 arcsecs
Range	0° to 360°

## Radio communication

Class 1 wireless communication device	
Communication distance	10 m typical operation

## Battery (rechargeable)

Technical data	
Max current	3.7 V DC
Battery life	3 hours typical operation (for new batteries)

## Power supply

USB power supply	
Shielded USB2	Full or high speed
For cable length less than 3 m	28AWG/2C (for signals), +24 AWG/2C (for power)

# Renishaw's machine measurement solutions

Renishaw offers a range of calibration solutions for improved machine performance, increased machine up-time and preventative maintenance schedules.

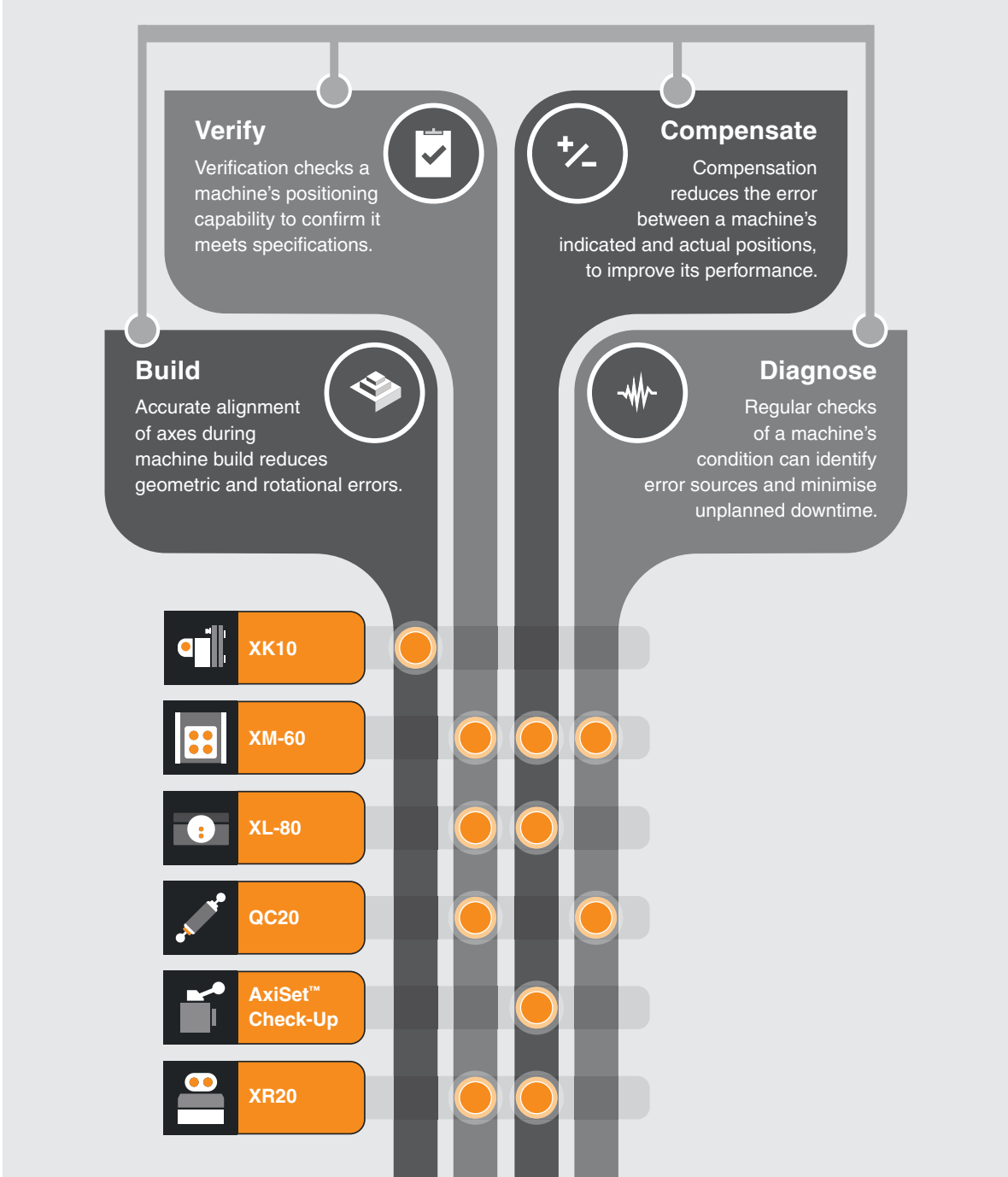

# Renishaw's innovation has transformed industrial metrology

Renishaw offers a range of calibration solutions for machine tools, CMMs and other applications:



## XL-80 laser measurement system

- The ultimate in traceable, versatile motion system analysis
- $\pm 0.5$  ppm certified linear measurement accuracy



## XM multi-axis calibrator system

- Measure six degrees of freedom in any orientation from a single set-up
- Unique technology, optical roll measurement and fibre optic launch

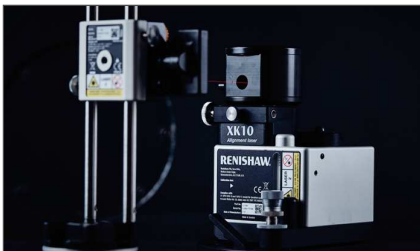

## XK10 alignment laser system

- Measurements are recorded digitally and easily exported
- Intuitive software provides a step-by-step approach for each measurement type



## QC20 ballbar

- The most widely used system for machine tool performance verification
- Reduces machine down-time, scrap and inspection costs



## AxiSet™ Check-Up for machine tools

- Rapid on-machine measurement of rotary axis performance
- Accurate detection and reporting of errors in rotary axis pivot points

## Service and quality

Our ongoing commitment to service and quality provides our customers with the complete solution



### Training

Renishaw offers an established range of comprehensive operator training courses either on-site or at a Renishaw training centre. Our experience in metrology allows us to teach not just about our products, but also underlying scientific principles and methods of best practice.

This enables our customers to get the most out of their manufacturing processes.

### Support

Our products enhance quality and productivity, and we strive for total customer satisfaction through superior customer service and expert knowledge of potential product applications. When you purchase a laser or ballbar system from Renishaw, you are buying into a worldwide support network that understands machine metrology and the service of production equipment.

Renishaw calibrations in the UK are traceable to the National Physical Laboratory, a signatory of the CIPM MRA. Calibration facilities worldwide can provide local laser calibration traceability.

### Design and build

Not only does Renishaw have comprehensive in-house design capability, its extensive manufacturing capacity allows it to produce nearly all components and assemblies in-house. This gives us the ability to fully understand and control our design and build process.

The performance of Renishaw lasers has been independently verified by the National Physical Laboratory (UK) and the Physikalisch-Technische Bundesanstalt (Germany).

### Certification

Renishaw plc is certified and audited regularly to the latest ISO 9001 quality assurance standard. This ensures all aspects of design, manufacture, sales, after sales support, and recalibration remain at the highest standards.

The certificate is issued by BSI Management Systems, an internationally recognised certification body, accredited by UKAS.

**bsi.**

[www.renishaw.com/xr20](http://www.renishaw.com/xr20)

+44 (0) 1453 524524

[uk@renishaw.com](mailto:uk@renishaw.com)

© 2022 Renishaw plc. All rights reserved. RENISHAW® and the probe symbol are registered trade marks of Renishaw plc. Renishaw product names, designations and the mark 'apply innovation' are trade marks of Renishaw plc or its subsidiaries. Other brand, product or company names are trade marks of their respective owners. Renishaw plc. Registered in England and Wales. Company no: 1106260. Registered office: New Mills, Wotton-under-Edge, Glos, GL12 8JR, UK.

WHILE CONSIDERABLE EFFORT WAS MADE TO VERIFY THE ACCURACY OF THIS DOCUMENT AT PUBLICATION, ALL WARRANTIES, CONDITIONS, REPRESENTATIONS AND LIABILITY, HOWSOEVER ARISING, ARE EXCLUDED TO THE EXTENT PERMITTED BY LAW.

### SALES & SERVICE:

A Tech Authority, Inc.  
13745 Stockton Ave.  
Chino CA 91710  
909-614-4522  
[sales@atechauthority.com](mailto:sales@atechauthority.com)